

Vibrations of the Atomic Nucleus

The nucleus can quiver, ring or even "breathe"; the coordinated motion of the nuclear particles reveals much about the forces between them. Six modes of vibration have been detected so far

by George F. Bertsch

Vibrating systems, from the swinging pendulum to the oscillating electromagnetic field of a light wave, have long had a privileged place in the physical sciences. The vibrational modes and frequencies observed in a system can reveal much about the nature of the forces acting within it. An analysis of vibrational motions was notably important in the understanding of atomic structure in the early years of the 20th century. More recently a richly varied spectrum of vibrations on a far smaller scale has been discovered in the nucleus of the atom. The study of the nuclear vibrations is proving to be a major source of information on the structure of the nucleus and on the forces that hold it together.

The protons and neutrons that make up a nucleus are collectively called nucleons. Quantum mechanics describes the arrangement and the motion of the nucleons by means of a wave function. For the stable nuclei found in nature the wave function does not change with the passage of time. The nucleus can be set in motion by external forces, however, leaving it internally excited. In the simplest excitations, called giant vibrations or giant resonances, all the nucleons oscillate coherently and the motion follows a simple pattern. The difference between coherent and incoherent motion in an excited nucleus is roughly analogous to the difference between the coherent motion of the liquid in a cup of tea that has been bumped and the random thermal motion of the molecules in the hot tea. In a coherent vibration there is a pattern: like liquid sloshing in a cup, the nucleons in a vibrating nucleus pass cyclically from one distribution to another.

The motion of the individual particles in a vibrating body can be coordinated in various ways, giving rise to the distinctive patterns of motion called vibrational modes. The molecules in the cup of tea can oscillate from the side of the cup to the center and back again or from one side of the cup to the other, and

the nucleons can also oscillate in several patterns.

So far six giant nuclear vibrational modes have been observed. Most of them have been detected experimentally only in the past few years. The giant vibrational modes fall into two classes. The first class consists of the modes the nucleus shares with other spherical bodies, such as a drop of water or the earth itself. The spherical vibrational modes of the nucleus that have been observed are, in the order of their discovery, the giant dipole, the giant quadrupole, the giant monopole and the giant octupole. The terms were borrowed from the names for electric fields of a given spatial complexity. For example, the protons in a nucleus vibrating in the quadrupole mode give rise to an oscillating electric field that resembles the field generated by four poles, or point charges.

The other class of nuclear vibrations involves the spin orientation of the nucleons. Protons and neutrons, like electrons and many other particles, spin on an internal axis. In the unexcited nucleus the spin axis is fixed with respect to the wave function of the nucleon and the spin orientation of the other nucleons. During a spin vibration some of the nucleon spins are tipped slightly and the spin axes begin to precess, that is, they describe circles around their original orientation. The precession of neutrons with respect to protons can be coordinated in different ways, giving rise to different spin-vibrational modes. For example, the neutron spins can be tipped in the same direction as the proton spins or in the opposite direction. As a result of the coordinated precession of the nucleons the nucleus can acquire a net spin or a net magnetic moment that oscillates at the precession frequency. So far two vibrations of this kind have been observed: they are called the giant Gamow-Teller resonance and the giant magnetic-dipole resonance.

An understanding of nuclear vibrations requires knowledge of the forces

acting between nucleons and the mechanical laws governing the motion of the nucleons under the influence of these forces. Given the complexity of the problem in the many-body system of the nucleus, physicists have long resorted to simple models. The nucleons are viewed as moving under the influence of a single generalized force whose effects approximate those of the interactions of the many nucleons. The vibrational modes of the nucleus provide an experimental check on the validity of the models; a theoretical justification requires the more fundamental quantum theory.

A body vibrating in a given mode oscillates at a specific frequency called the resonance frequency. The resonance frequency is determined in part by the internal forces opposing the motion of the oscillating particles. A drop of water and a solid sphere vibrating in the same spherical mode have different resonance frequencies. The solid strongly resists any distortion and has a high vibrational frequency. The liquid drop, on the other hand, returns to a spherical shape only because of forces associated with surface tension. These forces are quite weak and lead to a low vibrational frequency.

One model of the nucleus, the liquid-drop model, likens the forces acting between the nucleons to those acting between the molecules of a low-viscosity liquid. Another model, based on the shell model of the nucleus, likens the forces to those between the particles in an elastic solid. The resonant frequencies of nuclear vibrational modes were calculated from the liquid-drop model and from other simple models long before the vibrations could be excited in the laboratory and their frequencies measured. No single model accurately predicts the resonant frequencies of all modes of vibration. In some circumstances the nucleus acts like a liquid and in others like an elastic solid. In general its response is rather like that of a class of non-Newtonian fluids, of which Silly Putty is the most familiar example.

These substances respond elastically to sudden forces but flow as liquids over longer periods of time.

The most accurate and sophisticated description of nuclear vibrations is given by the time-dependent mean-field theory, which is based on quantum mechanics. In the mean-field theory the forces acting on the nuclear particles are calculated from the quantum-mechanical motion of the particles themselves, whereas the simpler models are based on specific assumptions about the relation between the forces and the particle motion. At first sight these approaches seem quite divergent, but the motion in the vibrations is simple, and in many cases it can be shown through the quantum theory that the assumptions made in the simple models are justified.

In general, nuclear vibrations are excited by bombarding nuclei with high-energy photons (quanta of electromagnetic radiation) or other particles. The vibrations are detected by observing how the projectile is absorbed or diffracted by the nuclei. In the case of the first vibration to be reported, the giant dipole vibration, both the excitation and the detection of the vibration proved to be relatively straightforward. For the other modes it has proved quite difficult to probe the nucleus in just the way needed to excite a particular vibration. Indeed, nearly 30 years passed between the discovery of the giant dipole vibration and the discovery of another giant vibrational mode.

If a nuclear vibration is to be excited, the first and simplest condition to be met is that the energy imparted to the nucleus must be equal to the energy associated with the vibration. The nucleus vibrates at extremely high frequency; the energy of the vibration is equal to the frequency multiplied by Planck's constant, and so the energy is also comparatively high. A typical vibrational frequency is 5×10^{21} hertz, which corresponds to a vibrational energy of 20 million electron volts (MeV). The energy of the photon or other particle that

VIBRATIONS OF NUCLEAR SHAPE, in which the nucleus is deformed from a spherical to an ellipsoidal or pear shape, are akin to the vibrations of a macroscopic body such as a drop of water. In both cases the vibration is a coherent oscillation of the particles of which the body is composed and hence gives rise to a pattern of motion of the body as a whole. The vibrations have had an important role in testing models of nuclear structure. Various models differ in their predictions of the frequency and the other characteristics of a given mode of vibration in the nucleus of a given atom. It seems that the nucleus sometimes acts like an elastic solid, sometimes like a liquid and sometimes like Silly Putty.

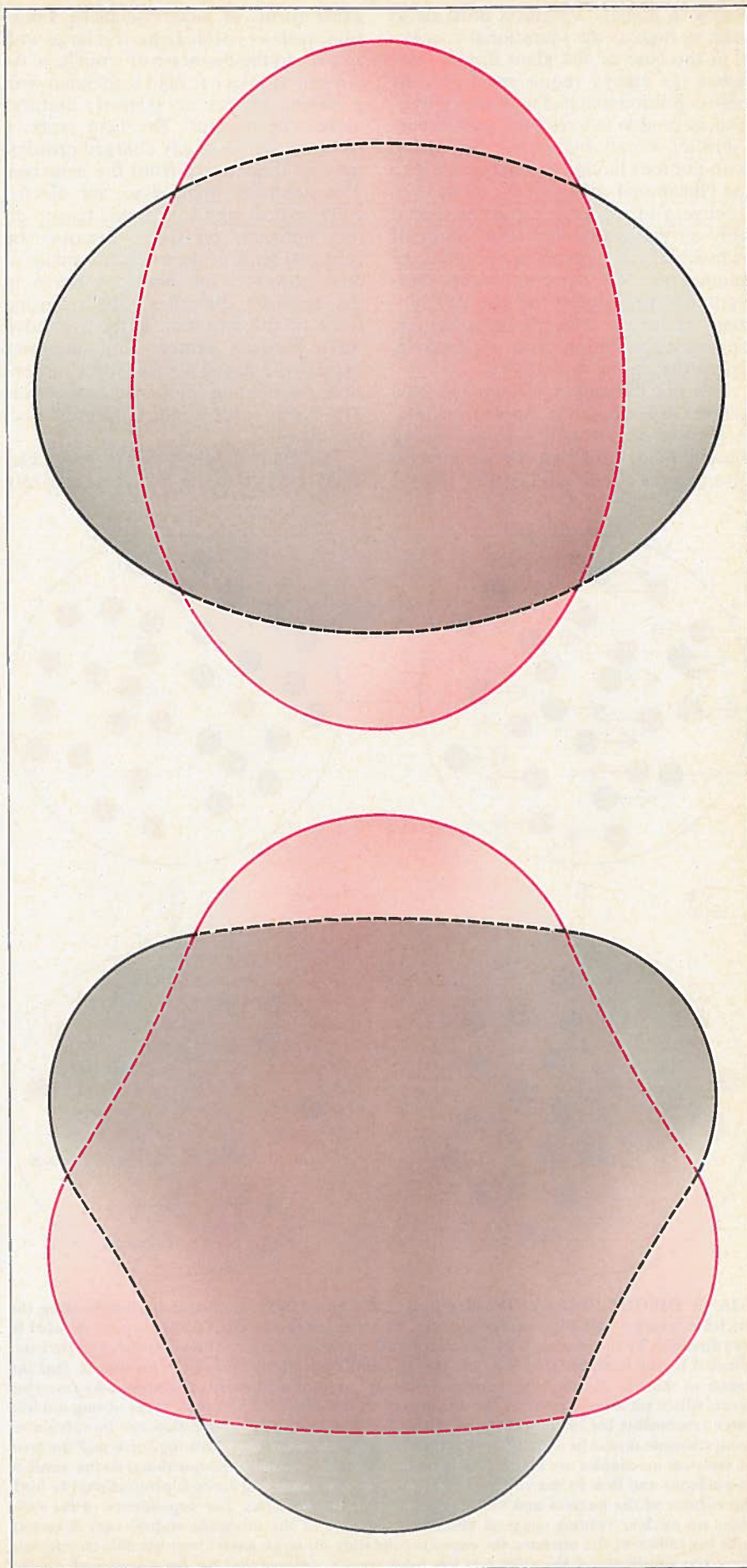

excites a nuclear vibration must be at least as high as the vibrational energy.

In the case of the giant dipole resonance the energy requirement was the only condition that had to be met. Physicists were able to excite the giant dipole vibration simply by bombarding nuclei with photons having an energy equal to the vibrational energy of the mode. The discovery of the giant dipole depended only on the availability of a source of monoenergetic high-energy photons, or gamma rays. The detection of the vibration followed closely on the development of such sources (bremsstrahlung, or braking radiation, from electron accelerators) in the mid-1940's.

It is not difficult to understand how gamma rays excite the dipole vibration. A photon carries with it an oscillating electric field. Although the wavelength of a gamma ray is smaller than that of

other forms of electromagnetic radiation, such as visible light, it is large with respect to the diameter of a nucleus. As a result the electric field associated with a passing gamma ray is nearly uniform across the nucleus. The field exerts a force on the positively charged protons, moving them away from the neutrons. The neutrons themselves are electrically neutral, and so the field has no direct influence on them. Because the center of mass of the nucleus remains at rest, however, the neutrons move in the opposite direction. The restoring force of the vibration is the attractive force between protons and neutrons, namely the strong nuclear force responsible for binding the particles together. The strong force is independent of electric charge.

The giant dipole was not only relatively easy to excite but also relatively

easy to detect. The photons that excite the vibration are simply absorbed in the nucleus. This phenomenon, which is a form of resonance, arises in any vibrating system excited by an external source. A person singing in a shower provides a familiar example of resonance. When the frequency of the voice matches a natural vibrational frequency of the air mass in the shower, the amplitude of the vibration becomes very large. The sound intensifies; the purity of the frequency is perceived in a resonant tone. In such situations the large amplitude leads to an increased absorption of energy. Similarly, when the frequency of the oscillating electric field associated with the gamma rays matches the resonance frequency of the dipole mode of the nucleus, the gamma rays are absorbed.

The tendency of the nucleus to absorb incident particles is expressed quantitatively as an effective cross section, measured in units of area. The dipole resonance is seen in a sharp increase in the absorption rate of the target at a particular photon energy. This is expressed as an increase in the effective absorption cross section of the nucleus. It is as if the nucleus suddenly grew larger and therefore intercepted more photons, although what actually changes is not the nuclear size but the absorbance. Because the response of a body to an electromagnetic force depends on the electric charge of the body, it is possible to determine from the effective cross section of the vibrating nucleus that all the protons in the nucleus are participating in the vibration; in short, the dipole vibration is in fact a giant vibration.

The next vibration to be reported was the giant quadrupole vibration. The quadrupole, unlike the dipole, is a shape vibration, in which the shape of the nucleus as well as the distribution of the nucleons changes. A nucleus vibrating in the quadrupole mode is distorted from a spherical shape to an ellipsoidal shape and moves back through a spherical shape to an ellipsoidal shape of another orientation. It is intuitively clear that the vibration could be induced by pushing in on the nuclear surface along one axis and pulling out along a perpendicular axis.

In order to excite the shape vibrations it is necessary not only to impart a given energy to the nucleus but also to distribute the energy in such a way that the nucleons are set in motion in different directions. Even though the vibrational energy of the quadrupole mode is from 10 to 20 MeV, within the energy range of gamma rays, they do not excite the quadrupole mode because they cannot meet the second condition. Gamma rays interact with the nucleus through the electromagnetic force; they can accel-

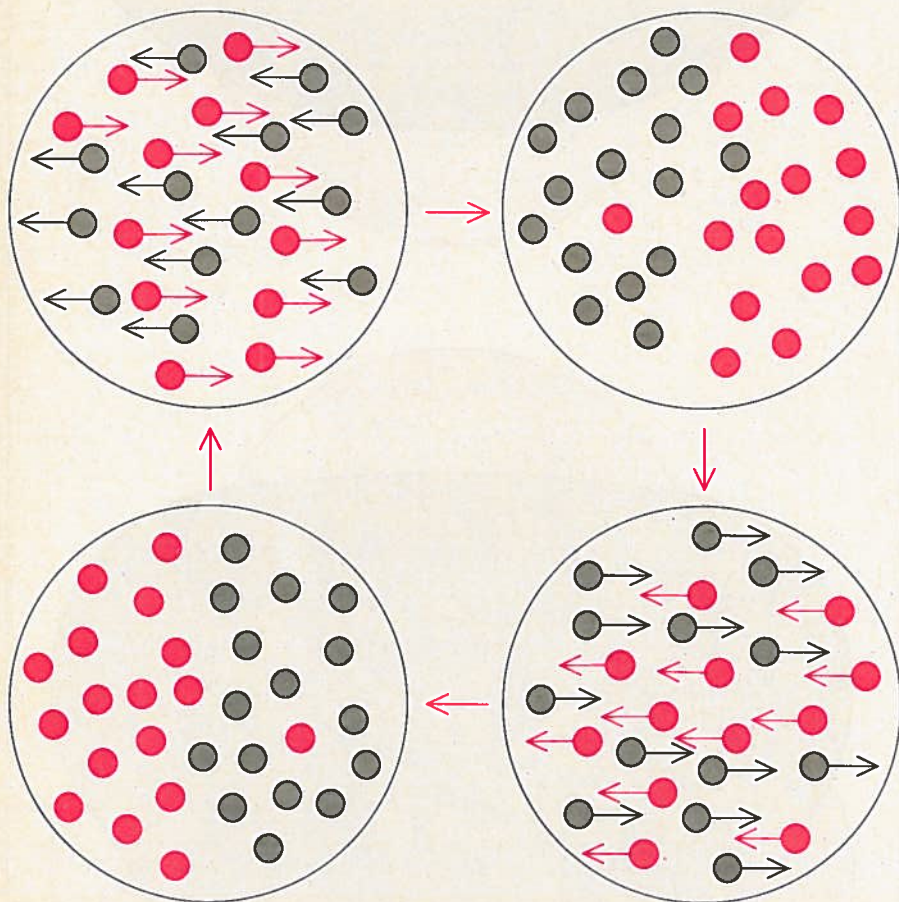

GIANT DIPOLE VIBRATION, identified in the late 1940's, is excited by bombarding the nuclei in a target with high-energy photons. The protons in a nucleus (color) are accelerated in one direction by the electric field associated with a passing photon. The neutrons (gray) are unaffected by the field, but they move in the direction opposite to that of the protons so that the center of mass of the nucleus remains stationary and momentum is conserved. The restoring force, which ultimately reverses the motions of the protons and neutrons, is the strong nuclear force responsible for binding them together. The frequency of the vibration can be calculated from a simple model in which only the inertia of the nucleons, the restoring force and the laws of classical mechanics are considered. The inertia of the system is proportional to the number of nucleons and thus to the volume of the nucleus. The restoring force is proportional to both the volume of the nucleus and the displacement of the nucleons. The dependence of the variables on nuclear volume suggests that the frequency of the vibration should vary inversely with the radius of the nucleus; the experimental data on large nuclei bear out this conclusion. Here the amplitude of the vibration has been greatly exaggerated for the purpose of clarity.

erate only the protons and, given the wavelength of the gamma rays, accelerate them only in one direction.

One answer to the problem is to excite the vibration by the inelastic scattering of a particle from the nucleus rather than by a complete absorption process. In classical physics a particle that strikes an extended object and bounces off can cause localized motion and leave the object vibrating. A similar phenomenon can take place in a quantum-mechanical system. The particles that can serve as projectiles for inducing nuclear excitations include electrons, protons and more massive nuclear particles such as the alpha particle (the nucleus of the helium-4 atom).

There are several advantages to choosing nuclear projectiles such as protons or alpha particles to excite the nucleus. The principal interaction in such events is mediated by the strong nuclear force, which is charge symmetric, that is, the same for protons and neutrons. The charge symmetry makes it easier to excite vibrations such as the quadrupole in which the protons and neutrons move together. Vibrations in which protons move opposite to neutrons, such as the dipole, are not excited at all by charge-symmetric forces. Thus to observe the quadrupole vibration without interference from the dipole, it is better to employ strongly interacting projectiles such as alpha particles rather than electrons, which interact with the electric field and can give rise to both kinds of vibration.

Another advantage of nuclear projectiles is that the different shape modes can be selectively excited. A fast proton going by a nucleus transmits a fleeting impulse to the nearby target nucleons, causing them to move in the wake of the projectile. The range of the strong nuclear force is small compared with the size of a nucleus, raising the question of how a coherent vibration of the entire nucleus can be set in motion. To understand how particular vibrations can be selected by the scattering process requires one of the basic notions of quantum mechanics, the wave aspect of particles. A proton going by a nucleus can be thought of as a wave enveloping the nucleus; the wave is subject to the laws of diffraction like any other wave.

Depending on how the wave interacts with the nucleus, it is diffracted with a characteristic pattern. For example, a light wave passing over a black sphere is diffracted into the shadow region, forming a pattern of rings in the center of the shadow. In the case of nuclear projectiles and targets the diffraction pattern depends on several factors. In order to produce a clear diffraction pattern at all, the wave must be absorbed in the interior of the nucleus. In physical terms, when the projectile penetrates the nu-

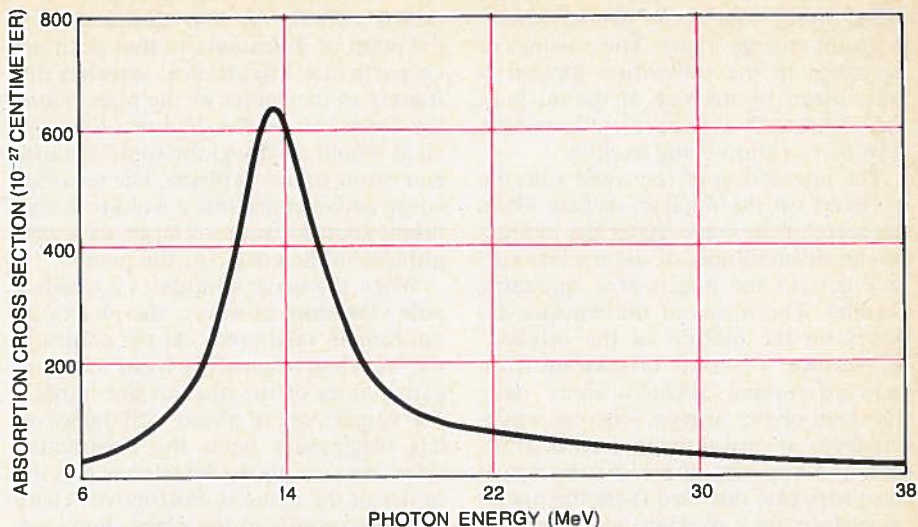

PEAK IN THE ABSORPTION CROSS SECTION of lead nuclei is evidence that they are vibrating in the dipole mode. Cross section is a measure of the fraction of the photons absorbed by nuclei. It increases dramatically when the photon frequency matches a vibrational frequency of the nuclei, a phenomenon called resonant absorption. The resonance in this nucleus is at a photon energy of 14 million electron volts (MeV), equivalent to a frequency of 3×10^{21} hertz.

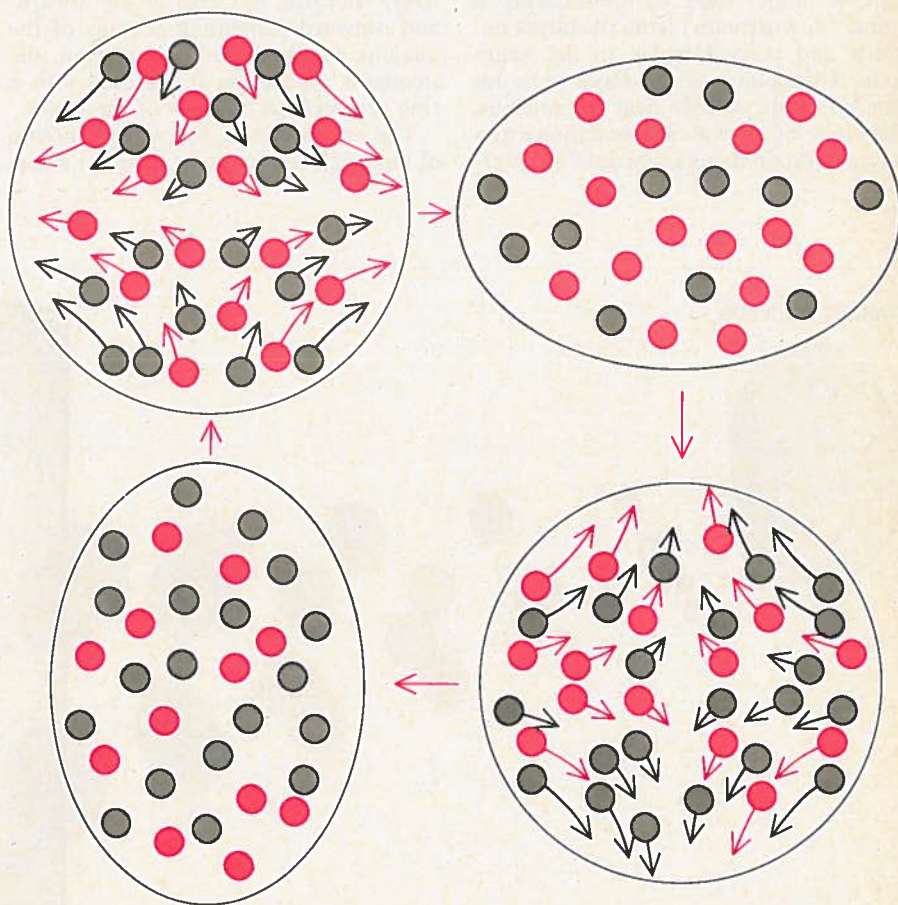

GIANT QUADRUPOLE VIBRATION can be excited by bombarding nuclei with projectiles that interact with protons and neutrons equally by means of the strong force. The quadrupole vibration therefore differs from the dipole in that the protons and neutrons move together rather than in opposite directions. As in the case of the dipole mode, the vibrational frequency can be calculated from the inertia of the system, the restoring force and the laws of classical mechanics. Again the inertia is proportional to the volume of the nucleus, but it is not immediately clear how to describe the restoring force. If the restoring force is assumed to be analogous to surface tension, as in a vibrating drop of water, the force is proportional to the surface area of the nucleus. If the restoring force is assumed to be analogous to stress energy, or resistance to deformation, as in a vibrating elastic solid, the force is proportional to the volume of the nucleus. Experimental data indicate that the frequency of the giant quadrupole vibration varies inversely with the radius of the nucleus, which favors the model based on an elastic solid.

cleus, it must interact so strongly that it does not emerge intact. The position of the rings in the diffraction pattern is determined by the size of the nucleus, the wavelength of the projectile and the type of vibration being excited.

The interaction of the wave with the nucleons on the nuclear surface alters the form of the wave. After the interaction each small area of the nuclear surface acts as the origin of a spreading wavelet. The phase of the wavelet depends on the motion of the originating surface. Wavelets originating from outward-moving surface areas have the same phase, or sign, whereas wavelets from inward-moving surface areas have the opposite phase. As the wavelets propagate outward from the nuclear surface they overlap and interfere. Whether the interference is constructive or destructive at any point depends on the phase of the various wavelets at that point.

The nature of the diffraction pattern can be understood by considering a plane "downstream" from the target nucleus and perpendicular to the beam axis. If the phase of the wave were not altered by its passage near the nucleus, the phase of the wavelets reaching a given position on the plane would be deter-

mined entirely by the distance from the point of diffraction to that position. Of particular importance, wavelets diffracted to the center of the plane along the beam axis in the shadow of the nucleus would all travel the same distance and would arrive in phase. The resulting constructive interference would create a bright spot (a region of large wave amplitude) in the center of the plane.

When the wave stimulates a quadrupole vibration, however, the phases do not remain unaltered. On the contrary, the wavelets originating from the elongating sides of the nucleus are initially 180 degrees out of phase with the wavelets originating from the contracting sides. As a result the interference in the center of the plane is destructive. There are other points in the plane, however, where the distance to an elongating region and the distance to a contracting region differ by exactly half a wavelength. The wavelets arrive at these points in phase, interfering constructively. Because the axes of the inward- and outward-deforming regions of the nucleus can have any orientation, the strongest diffraction is directed into a ring centered on the axis of the beam.

The amplitude of the wave function of a particle at any point in space deter-

mines the probability that the particle will be found at that point. Consequently the projectile particles are most likely to be scattered into regions of constructive interference, where the amplitude of the wave function is largest.

Like absorption, inelastic scattering can be measured in terms of a cross-sectional area. Even in the absence of a vibrational resonance a certain fraction of the projectiles bombarding a target are scattered inelastically, and the fraction scattered in any one direction varies smoothly with the angle between the beam axis and the scattering direction. The quadrupole vibration shows up as a sharp increase in the number of particles scattered inelastically in particular directions.

For a quantitative prediction of the cross section as a function of scattering angle the interaction of the wave with the nucleus is described by a phenomenological optical model. The wave equation is then solved numerically to find the precise cross section. The cross section for the quadrupole mode reaches its maximum value at an angle that depends on the size of the nucleus as well as on the wavelength of the projectile. For example, in the case of the lead 208 nucleus bombarded by 100-MeV al-

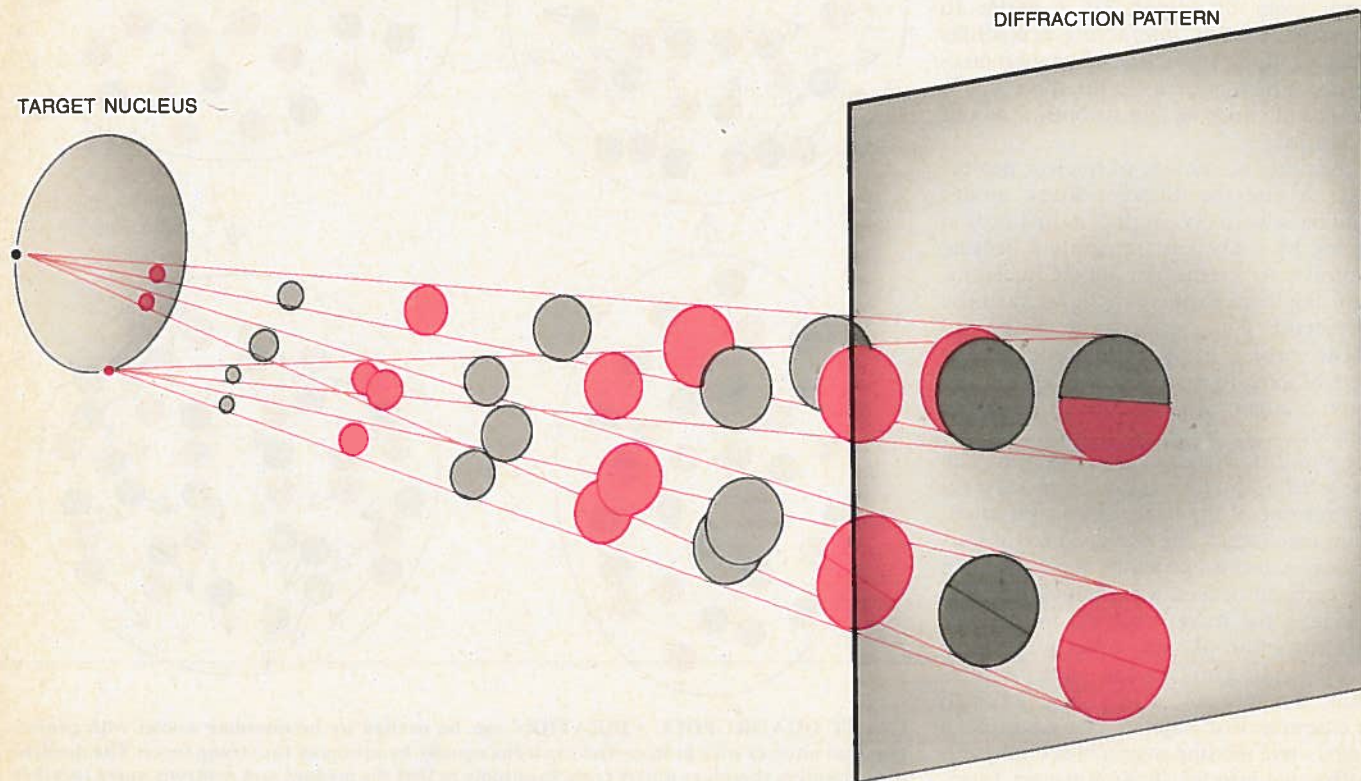

ANNULAR DIFFRACTION PATTERN formed when projectiles are scattered by nuclei in the target is associated with the quadrupole vibration. The projectile particle can be described quantum-mechanically as a plane wave perturbed by its interaction with the surface of the nucleus. The interaction of the wave with the nucleons is attractive along one axis, so that the nuclear surface is pulled outward, and repulsive along the perpendicular axis, so that the surface is pushed inward. The single plane wave is diffracted into many small circular

waves that propagate outward and interfere with one another. The waves originating from the inward-deforming regions of the nucleus are 180 degrees out of phase with those from the outward-deforming regions. (Here the phase differences are represented by color differences.) The pattern created by the interference of the waves is determined by this phase difference. Waves arrive at any point along the beam axis out of phase and cancel. There are points off the axis, however, where the waves arrive in phase and interfere constructively.

pha particles, the main diffraction peak is at five degrees from the beam axis.

The third nuclear vibrational mode to be observed, the giant monopole vibration, is excited and detected in much the same way as the giant quadrupole. The monopole vibration is a "breathing" mode: the nucleons move inward and outward from the center of the nucleus in phase with one another, so that the nucleus expands and contracts. Intuitively it would seem that the best way to induce this motion would be to push uniformly on the surface of the sphere or, equivalently, to pull outward in a radial direction.

Such perfect conditions for exciting the monopole vibration cannot be achieved with inelastic scattering. If the projectile hits the nucleus, it loses most of its energy and leaves the nucleus in a very highly excited state. Only when the projectile grazes the surface of the nucleus is the interaction gentle enough to excite the simple vibratory motion. The part of the surface the projectile wave acts on is a ring-shaped region circling the beam axis. As in the quadrupole excitation, the interaction gives rise to many wavelets originating from each small area of the nuclear surface. The wavelets interfere as they spread out from the surface of the sphere. Because the monopole excitation is completely symmetric, the wavelets start out from the curved surface with the same phase. Hence along the beam axis, where the distance to all areas on the periphery of the sphere is equal, the wavelets arrive in phase and interfere constructively.

The diffraction pattern formed by the particles exciting the monopole vibration is a prominent spot centered on the beam axis and surrounded by faint rings. In other words, the monopole vibration is characterized by a maximum in the scattering cross section at zero degrees from the beam axis. The pattern is essentially the same as the one formed by particles diffracted by a nonvibrating nucleus. Indeed, it was largely for this reason the monopole vibration was harder to detect than the quadrupole vibration; it proved difficult to separate the particles that are inelastically scattered along the central axis of the beam from the particles that pass through the target without interacting with the nuclei. The only way to discriminate between the inelastically scattered particles and the beam particles is by measuring the energy dependence of the inelastic scattering.

At this point it is possible to return to the question of why it took so long to obtain experimental evidence of quadrupole and monopole vibrations. Rough predictions of the vibrational frequencies of these modes had been

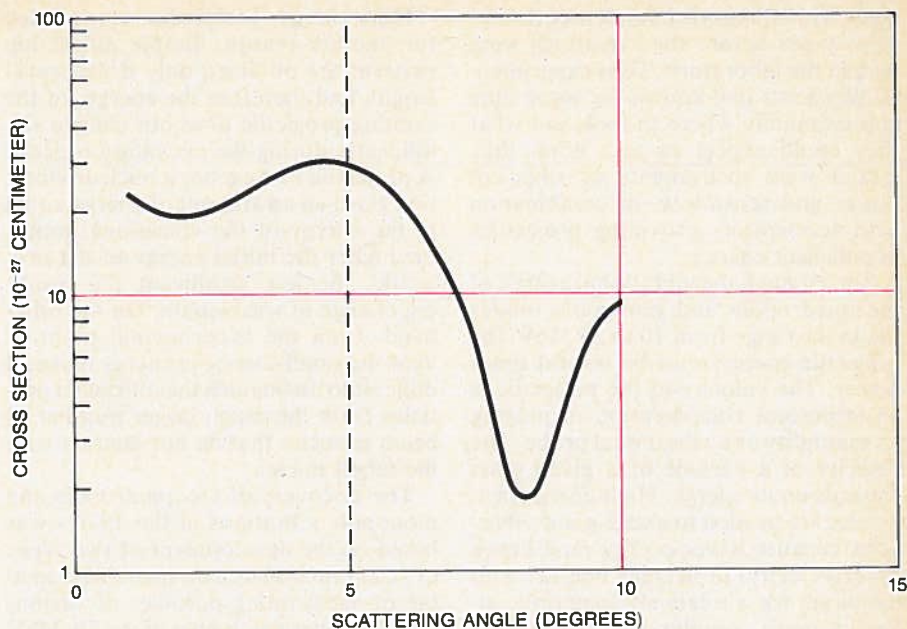

PERCENTAGE OF PARTICLES scattered at a given angle to the beam axis increases sharply when the quadrupole vibration is excited. The scattering cross section varies with angle in a way that reproduces the diffraction pattern associated with the quadrupole mode. The scattered particles have a specific energy, namely the energy of the impinging beam minus the vibrational energy of the quadrupole mode. In this case the projectiles are alpha particles with an energy of 96 MeV striking a target consisting of the isotope samarium 144. The quadrupole mode is preferentially excited with a scattering angle of five degrees to the beam axis.

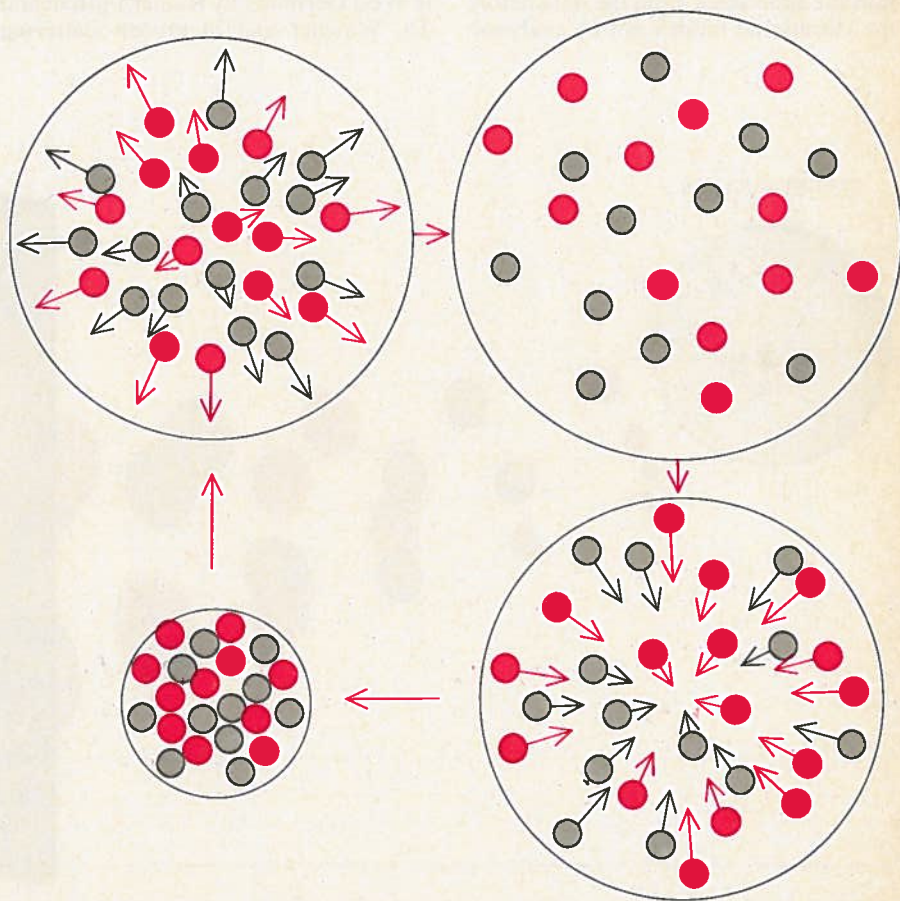

GIANT MONOPOLE VIBRATION is also called the breathing mode: in it the nucleus expands and contracts. In the model of the giant monopole vibration based on classical mechanics the restoring force is the resistance of nuclear matter to compression. The observed frequency of the monopole vibration gives a value for the compressibility coefficient of nuclear matter.

made from theoretical models of the nucleus years before the vibrations were seen in the laboratory. Thus experimental physicists had known for some time approximately where to look and what they could expect to see. What they lacked were instruments of sufficient power and sensitivity, in combination with accelerators providing projectiles of sufficient energy.

Even though the vibrational energy of the quadrupole and monopole modes lies in the range from 10 to 25 MeV, the projectile energy must be several times higher. The velocity of the projectile is an important consideration in judging its suitability as a vibrational probe. The velocity of a particle of a given mass depends on its energy. High-energy projectiles are needed to excite giant vibrations because lower-energy (and hence lower-velocity) projectiles interact with the target for a relatively long time, allowing more complex excitation processes to take place. A slower projectile might induce a vibration composed of several fundamental modes, or it might induce more complicated motions in the nucleus by exchanging nucleons with the target. These processes do not give rise to a diffraction pattern but contribute to a background cross section that must be subtracted from the data before the vibrational modes can be analyzed.

High-energy projectiles are needed for another reason. Simple diffraction patterns are obtained only if the wavelength, and therefore the energy, of the exciting projectile does not change significantly during the excitation process. A projectile that excites a nuclear vibration gives up an amount of energy equal to the energy of the vibrational mode; the higher the initial energy of the projectile, the less significant the resulting change in wavelength. On the other hand, from the experimental point of view the small change in energy makes it difficult to distinguish the diffracted particles from the much larger number of beam particles that do not interact with the target nuclei.

The discovery of the quadrupole and monopole vibrations in the 1970's was based on the development of two types of scientific instrument: machines capable of accelerating particles of various kinds to energies higher than 50 MeV and sensitive magnetic spectrometers (spectrographs) capable of separating particles of slightly different energies. Once the instruments were available nuclear vibrations began to be reported in rapid succession. The giant quadrupole vibration was first seen in electron-scattering measurements done at Darmstadt in West Germany by Rainer Pitthan and Th. Walcher and in proton-scattering

measurements done at the Oak Ridge National Laboratory by F. E. Bertrand and M. B. Lewis. The giant quadrupole vibration has now been excited in practically all species of nuclei; it has a frequency that varies inversely with the radius of the nucleus. The equivalent energy is in the range from 10 to 20 MeV.

The first indications of the breathing mode were found with deuteron scattering by Nadine Marty and her collaborators at the Institute of Nuclear Physics of the University of Paris (Paris-Sud) at Orsay. Observation of the diffraction peak in the forward direction, providing definitive proof of the monopole mode, was first obtained in 1977 with alpha-particle scattering by a group at Texas A&M University led by Dave H. Youngblood. Like the quadrupole, the breathing mode has a frequency that decreases with increasing size of the nucleus. In energy units the range is from 15 to 25 MeV, slightly higher than the energy of the quadrupole. The giant octupole vibration was first detected in 1980 in scattering experiments done with 800-MeV protons at the Los Alamos Scientific Laboratory. The octupole mode has an energy ranging from 20 MeV in heavy nuclei to 30 MeV in lighter nuclei.

The history of theoretical speculation about nuclear vibrations and the interplay between theory and experiment

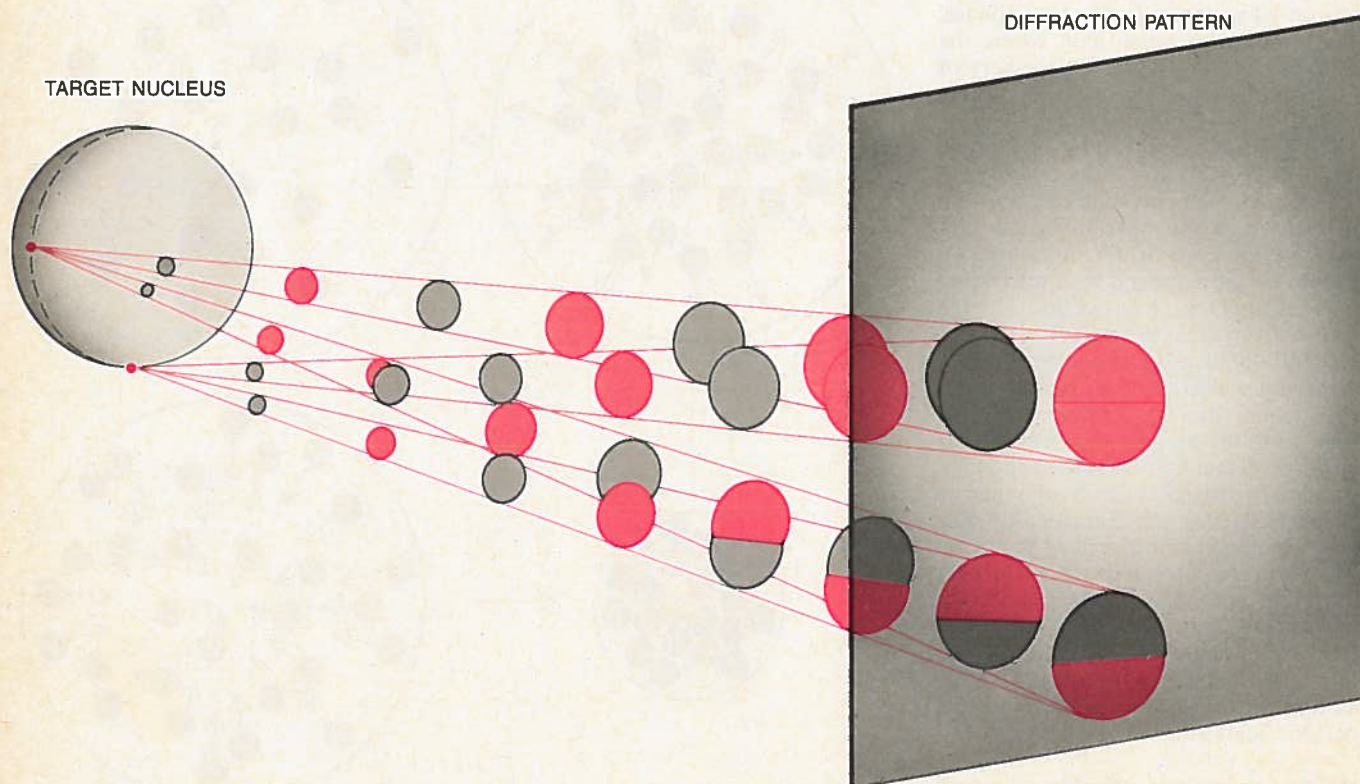

DIFFRACTION PATTERN associated with the monopole vibration is a point on the beam axis. The pattern is known as the Poisson spot; in the 19th century Siméon Denis Poisson proved mathematically that if light consists of waves, there should be a small bright spot in the shadow of a sphere. Poisson put forward his argument as

a proof that light cannot have a wave nature, since no such diffraction pattern had been seen at the time. The pattern is formed by a disk or a sphere whose surface absorbs light uniformly. Particles that interact uniformly with the surface of a nucleus, as do those that excite the monopole vibration, are diffracted with the same spot.

form an equally interesting thread in the story. Theoretical calculations predicted a nuclear phenomenon for which there was no experimental evidence, giving physicists some clues, albeit imperfect, about where to look and what it would look like if it were found. The experimental evidence in turn showed where the simplified theoretical models of vibrating nuclei were in error and helped to lay the groundwork for more powerful models based on more accurate assumptions.

The frequency of a vibrating body depends on two properties: the inertia of the constituent particles, which governs how quickly they respond to a force, and the restoring force, which opposes the displacement of the particles. The larger the inertia is, the slower the body vibrates, and the stronger the restoring force, the higher the vibrational frequency. More quantitatively, the square of the vibrational frequency is directly proportional to the strength of the restoring force and inversely proportional to the inertia.

In 1944 the Russian physicist Arkadii B. Migdal predicted the frequency of the dipole vibration by applying those simple mechanical laws to the nucleus. It is easy to construct a plausible model of the inertia of the nucleus vibrating in the dipole mode. Assuming that all the nucleons are moving with the same speed in the dipole vibration (but in different directions for protons and neutrons), the inertia is equal to the total mass of the nucleus. Modeling the restoring force is more difficult, and it is here the simplification in theoretical models of the nucleus generally comes in. In the case of the dipole mode the restoring force is mainly due to the attractive strong force between protons and neutrons. The strength of this force in a vibrating nucleus can be inferred from the binding energy of various nuclei. Among all nuclei those with nearly equal numbers of protons and neutrons have the greatest binding energy, apart from the effects of the protons' electric charge. A model of the proton-neutron interaction is constructed to fit the systematic variation in binding energy with nuclear composition; the same model is then used to calculate the restoring force when the nucleons are displaced in the dipole mode.

The measured frequency of the dipole vibration agrees remarkably well with the frequency Migdal predicted from his model. Nevertheless, we now know that more than the potential energy of separated protons and neutrons needs to be considered in modeling the restoring force of the dipole mode; furthermore, the inertial mass of the system is not simply that of free nucleons. The inertial mass is slightly smaller than Migdal

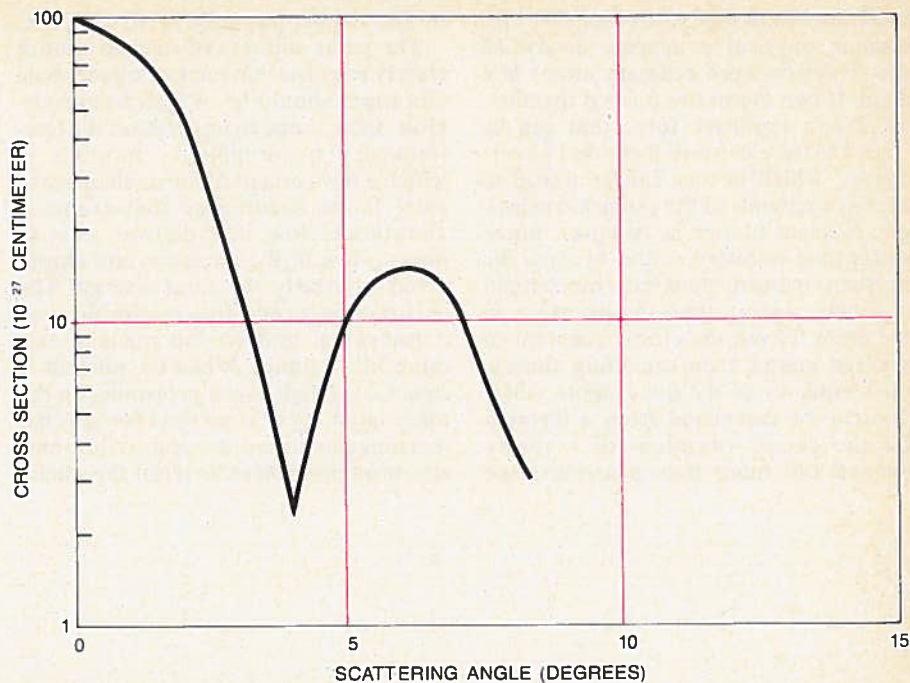

SCATTERING CROSS SECTION of nuclei vibrating in the monopole mode peaks on the beam axis (at zero degrees). The graph shows the angular distribution of alpha particles inelasticly scattered from lead nuclei. The monopole vibration was identified seven years later than the quadrupole vibration, largely because of the difficulty of separating particles scattered along the beam axis from the particles passing through the target without being deflected.

assumed because in a quantum-mechanical description of the nucleus, protons and neutrons are not the only particles present. There are also pi mesons, or pions, the subatomic particles responsible for transmitting much of the strong interaction between nucleons. Pions are much lighter than nucleons and hence reduce the average inertial mass. For the dipole vibration, however, the discrepancies are minor and the predictions based on binding-energy calculations are essentially correct.

Another model of the nucleus, the liquid-drop model, was proposed by Niels Bohr in 1936. Bohr took note of the fact that a nucleon in the interior of a nucleus is surrounded by other nucleons that pull it equally in all directions, so that the net force is zero. A nucleon at the surface, on the other hand, has other nucleons on only one side, and so it is pulled toward the center. The effect on the surface nucleons is analogous to the surface tension of a drop of water; in both cases the force tends to make the system take on a spherical shape.

The frequencies of liquid-drop vibrations were worked out by Lord Rayleigh at the end of the 19th century. In 1952 Niels Bohr's son, Aage Bohr, and Ben R. Mottelson suggested that the liquid-drop model might be applied to vibrations such as the quadrupole vibration, in which the nucleus oscillates between spherical and deformed shapes. In these vibrations the dominant restoring force should be the nuclear surface tension.

Because the nuclear surface tension is relatively weak, Bohr and Mottelson predicted that the frequency of the quadrupole mode would be low. Quadrupole-shaped motions were found at low frequencies, but only a few of the nucleons, typically fewer than 10 percent, participate in the motions. The giant quadrupole vibration has a frequency much higher than the predicted one.

The problem with the liquid-drop model is that nucleons are not free to move in the nucleus in quite the same way as molecules are free to move in a drop of liquid. Nucleons must obey the Pauli exclusion principle, which states that no two identical nucleons can have exactly the same quantum-mechanical state of motion. As a consequence two protons or two neutrons having the same spin orientation must occupy different orbits in the nucleus. Their motion is thereby constrained to some extent; they must keep out of each other's way.

To include the quantum effects properly requires a much more elaborate theory, which I shall describe below. The theory gives a quite simple and unexpected result for the giant vibrations, namely that the nucleus has a rigidity making it respond more like a solid than a liquid. The restoring force for the quadrupole vibration is governed by the elastic constant of the nuclear medium. The value of the elastic constant can be estimated from the quantum theory; it is proportional to the kinetic energy of

the nucleons in their shell-model orbits. Similar physical principles determine the forces between ordinary atoms in a solid. If two atoms are pushed together, there is a repulsive force that can be traced to the electrons' increased kinetic energy, which in turn can be traced to the requirements of the exclusion principle. Nuclear matter is, however, much stiffer than ordinary matter because the nucleons in the nucleus have much higher kinetic energy than the electrons in the atom. Given the elastic constant of nuclear matter from quantum theory, the frequency of the quadrupole vibration can be calculated from a formula for the elastic vibrations of a sphere worked out more than a century ago

by the British physicist A. E. H. Love.

The great stiffness of nuclear matter clearly suggests that nuclear quadrupole vibrations should be of high frequency. How, then, is one to understand the low-frequency quadrupolelike motions in which a few percent of the nucleons take part? If the disturbance that excites a vibration is slow, it is relatively easy to move a few of the nucleons into empty orbits of nearly the same energy. The exclusion principle does not forbid such a transition, and so the nucleus acts more like a liquid. When the nucleus is struck by a high-speed projectile, on the other hand, there is no time for internal rearrangement and the giant vibrations are more prominent. Overall the nucle-

ar response to an external force resembles that of Silly Putty, which responds like an elastic solid to sudden forces and like a viscous liquid to slow ones.

The frequency of the monopole vibration can also be worked out from a simple model of the nucleus in which only the inertia of the nucleons and the dominant restoring force of the vibration are considered. The restoring force in this case is the resistance of nuclear matter to compression. (In the "breathing" motion of a monopole vibration the nucleus is alternately compressed and rarefied.) The breathing model was suggested long before quantum calculations of the monopole vibration were available; later mean-field theory confirmed the

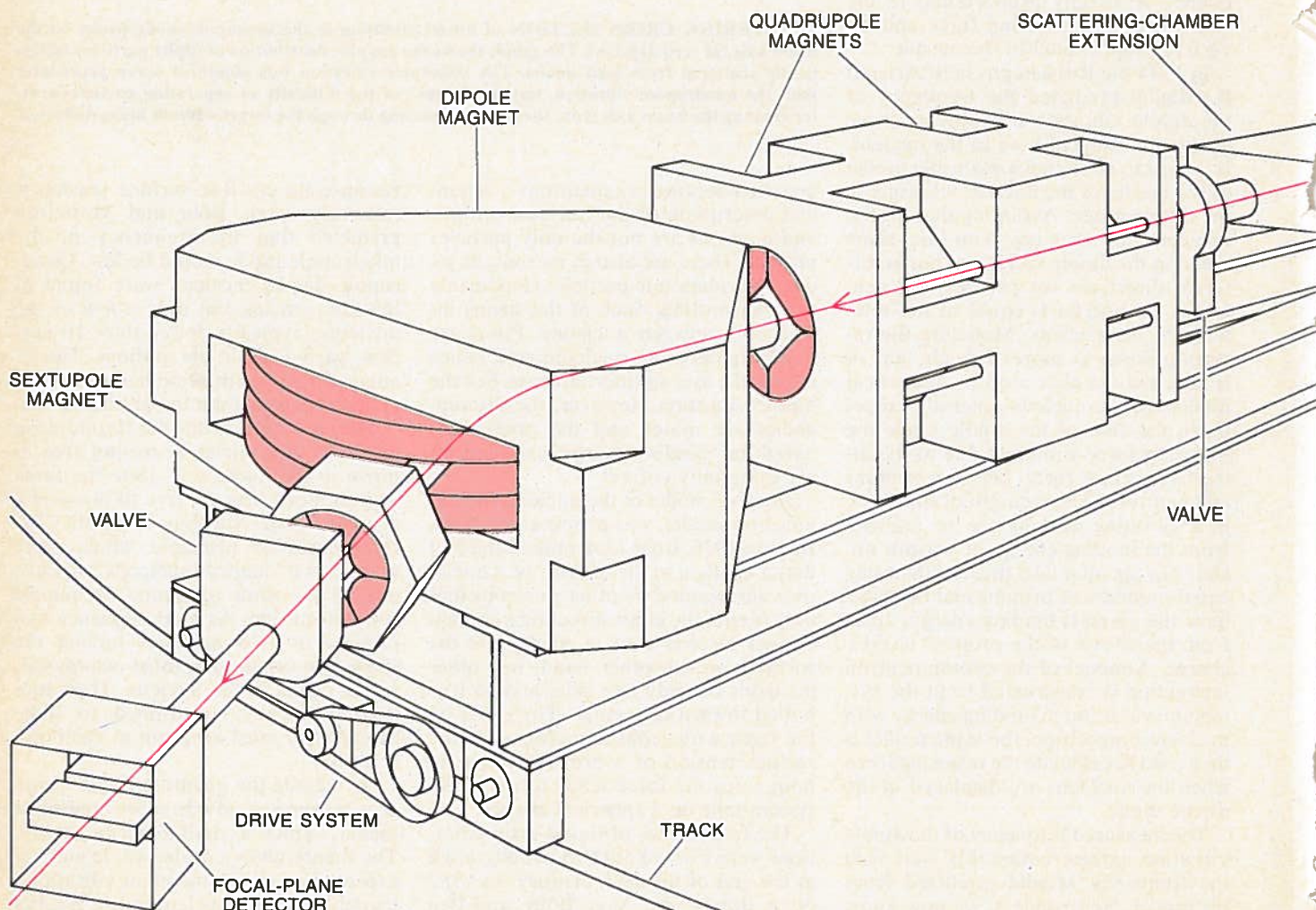

THE MAGNETIC SPECTROGRAPH, a sophisticated version of the mass spectrometer, separates particles that have lost a specific amount of energy in exciting a nuclear vibration from other particles in a beam. The beam of particles from an accelerator is directed onto a thin foil of target material in the scattering chamber of the spectrograph. After interacting with the target the projectiles are sorted according to energy by a dipole magnet that deflects them into a circu-

lar path. A particle with a higher energy follows a wider arc in the magnetic field than a particle with a lower energy. Only particles with the selected energy pass through the magnet to the detector. Quadrupole magnets focus the beam; a sextupole magnet corrects focusing aberrations. In the Michigan State University spectrograph shown here the detector is a multiwire gas ionization chamber. The high-energy particles ionize atoms of gas in the chamber. The electrons lib-

validity of a force based on the compressibility of nuclear matter. It has not been possible, however, to calculate the compressibility coefficient reliably or to measure it by other means, so that the observation of the monopole vibration provides the most direct information on the compressibility of nuclear matter. The coefficient derived from the breathing model together with the observed frequency of the vibration has nonetheless received spectacular confirmation from a very different source.

When a massive star comes to the end of its life, the inward-pushing gravitational forces are no longer balanced by the outward pressure of hot gases produced by nuclear reactions and the star

begins to collapse. Gravitation compresses the core of the star to the density of nuclear matter, at which point the great resistance of nuclear matter to further compression begins to counteract the gravitational collapse. Depending on the compressibility of nuclear matter (among other things), the collapse may continue to the formation of a black hole or it may be stopped by an outward-moving shock wave that blows off the outer layers of the star in a supernova explosion. A dense neutron star is left at the center of the explosion; the maximum mass such a star can have depends directly on the compressibility coefficient. To date there is good agreement between the observed range of neutron-star masses and the compressibility coefficient deduced from the nuclear monopole vibration.

An exact theory of nuclear structure (as opposed to a model) would specify in detail the forces exerted by each nucleon on every other nucleon. In a nucleus of moderate size, for example oxygen 16, there are 120 pairings of the nucleons to be considered. Furthermore, according to quantum mechanics, all the possible configurations of the nucleons have to be considered simultaneously, and each configuration must be assigned some amplitude in the quantum wave equation. The relative amplitudes would be independent of time in a description of the unexcited nucleus, but in the vibratory motion they would of course vary with time. In either case the task of describing the system in this way is mathematically intractable. The shell model offers a simplified description; it is approximate but nonetheless retains most of the quantum physics and is quite accurate in accounting for many of the properties of nuclei. The shell model does not attempt to calculate all the interactions of the individual nucleons. Instead a single potential, or mean field of force, is defined; it represents the collective effect of all the particles on any given particle. The quantum wave equation is solved for one particle at a time in this common potential.

The problem then becomes one of choosing the appropriate potential. The starting point is the distribution of particles in an unexcited nucleus; summing the fields associated with the individual nucleons yields an approximate collective potential. The next step is to go back and alter the wave functions of the individual particles in accordance with the estimated potential. By successive approximation one finds a potential and a set of particle wave functions that are mutually consistent. This method was introduced by William Hartree as a means of describing the electrons in an atom; the technique has been very useful in nuclear physics and is the basis of

the nuclear shell model. The usual shell model is a static theory, but one can easily allow the potential field to depend on time in order to describe vibrations.

The time-dependent mean-field theory was first applied to nuclear vibrations in the 1960's. The change in the potential caused by an external force is calculated from the change in the distribution of the nucleons from one point in the vibrational cycle to the next. Again a repetitive procedure is employed to arrive at an accurate description of the field. The potential acting on the nucleons is calculated from their movement. The resulting approximation of the field in turn serves to refine the initial wave functions, which specify a new approximate potential. Ultimately a set of wave functions is found that fits both the distribution of particles and the potential field for the succeeding point in the vibrational cycle. The procedure can be simplified for small-amplitude vibrations.

The mean-field theory, rather than the simpler models of the nucleus, has provided the theoretical basis for vibrational studies for the past 10 years. In 1952 Mottelson predicted the frequency of the quadrupole vibration on the basis of the liquid-drop model; as I have stated, the predicted frequency turned out to be too low. In 1969 Mottelson predicted the frequency of the same vibration on the basis of the mean-field theory. When the vibration was finally detected in 1971, the observed frequency agreed with his second prediction.

The dipole, quadrupole and monopole vibrations are all geometric deformations with clear analogues in the vibrations of ordinary macroscopic bodies. The spin vibrations of the nucleus are quite different. Spin is an intrinsically quantum-mechanical property, and analogous motions are not to be found in macroscopic systems. The spin vibrations differ from the shape vibrations in that the spatial distribution of the nucleons may remain frozen with only the spin orientation varying with time. When there is no spatial motion, the Pauli principle is more restrictive and only a few of the nucleons can participate in the spin vibration. In the unexcited nucleus the spins are nearly all paired; the excitation process tips the spins of some of the nucleons and they precess. There are several ways the spin precession can be induced and detected. The nucleon spin has an associated magnetic moment and can interact through the electromagnetic field. Hence photon absorption and electron scattering are two techniques for studying spin properties of nuclei.

There are other fields as well that interact with nucleon spins. One of these is the field of the pi meson. When a pion

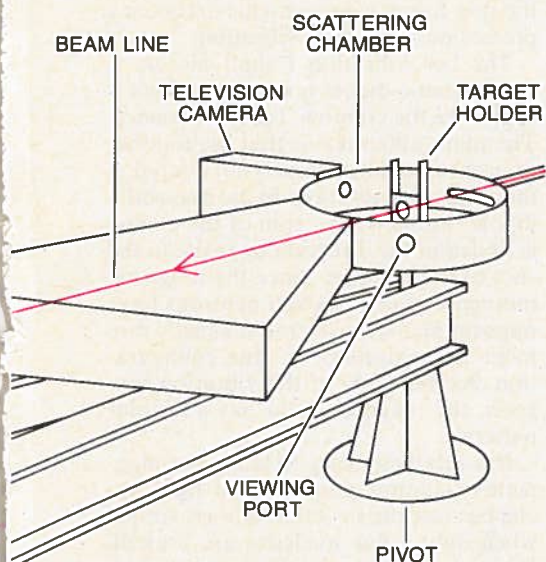

erated are attracted to the closest point on an array of parallel wires in the detector chamber. Currents induced in the wires are individually detected to determine the position of the particle. The spectrograph can be pivoted around the chamber so that the scattering probability can be measured as a function of angle.

is absorbed by a nucleon, it changes the nucleon's spin orientation. An individual nucleon is surrounded by a pion field, so that even nucleon projectiles can induce spin vibrations. Another field that interacts with spin is the weak field, mediated by the recently observed W particle. The weak field is responsible for beta decay, one of the major processes in the formation of stable elements. In beta decay a proton is changed into a neutron or vice versa, usually with a reorientation of the spin of the affected particle.

One of the best experimental techniques for studying spin vibrations is the inelastic scattering of high-energy protons from a nuclear target. The pion field of the proton interacts with nucleons in the target, and much of the character of the interaction is due to the pion. If the exchanged pion is a neutral one, the electric charges of the projectile and the target remain the same and the collision is seen as an instance of ordinary inelastic scattering. It is also possible to exchange a charged pion, in which case the charges of the projectile and the target both change. The bombarding proton is turned into a neutron, and in the target one of the neutrons is changed

into a proton. In spite of the charge exchange the same diffractive effects determine the angular distribution of the scattered beam. The simplest possible spin vibration, which is uniform over the entire surface of the nucleus, gives rise to a diffraction pattern with a peak at zero degrees, just as the giant monopole vibration does.

The charge-exchange spin vibration is called the giant Gamow-Teller resonance because of its relation to the spin-flip beta-decay process originally described by George Gamow and Edward Teller. The giant Gamow-Teller resonance was first observed in 1976 by Robert Doering, who was then a graduate student at Michigan State University. The energy of the proton beam was rather low and the forward diffraction peak was just barely distinguishable from the background of neutrons arising from more complex interactions with the target. More recent experiments done at the Indiana University Cyclotron Facility with higher-energy beams have given diffraction patterns in which the background is much reduced. The clearer patterns allow the properties of the vibration to be measured more accurately. The energy

of the vibration lies in the range from 10 to 15 MeV.

The measured energies can be compared with theoretical predictions to check our understanding of the spin forces. There are no classical models for the spin vibrations, but the mean-field theory can be applied. The predictions agree well with the measurements, demonstrating that the theoretical description of the spin forces, based largely on the pion fields of the nucleons within the nucleus, is essentially correct. Even apart from theory, the existence of the giant Gamow-Teller resonance had long been suspected from indirect evidence. Beta-decay transition rates tend to be much lower than expected from the shell model, showing that the amount of spin precession at low frequency is small. From this finding one infers that the spin forces cause a higher-frequency precession—the giant vibration.

The last vibration I shall discuss is the magnetic-dipole resonance, which is much like the Gamow-Teller resonance. The main difference is that the number of protons and neutrons is not altered in the magnetic vibration. In the magnetic-dipole resonance the spin of the proton is tipped in the direction opposite to the spin of the neutron. Since the magnetic moments of protons and neutrons have opposite signs, the overall magnetic moment is maximized by this configuration. As the name of the vibration suggests, the magnetic field has a dipolar pattern.

It is relatively easy to study the magnetic-excitation properties of light nuclei because the structure is fairly simple when only a few nucleons are present. Depending on the nucleus and the degree of pairing, a prominent spin vibration may be present. Until recently, however, little was known about the magnetic excitations of heavy nuclei, in spite of a long search for the magnetic-dipole resonance. This situation has changed recently; in 1981 the magnetic-dipole resonance was found in the nucleus of zirconium 90 by using inelastic proton scattering to excite the spins of the target nucleons. The experiment was done at Orsay with 200-MeV protons and a spectrograph capable of identifying inelastic-scattering events at angles as small as two degrees. The excitation energy of the magnetic-dipole resonance ranges from 8 MeV in heavy nuclei to 15 MeV in light nuclei.

One interesting and somewhat puzzling aspect of both the Gamow-Teller and the magnetic-dipole resonances is that only a third of the expected number of nucleons seem to participate in the vibration in heavy nuclei. This is one of the reasons it was difficult to observe the magnetic-dipole resonance. The reduced strength has led nuclear physicists to look for a complete understand-

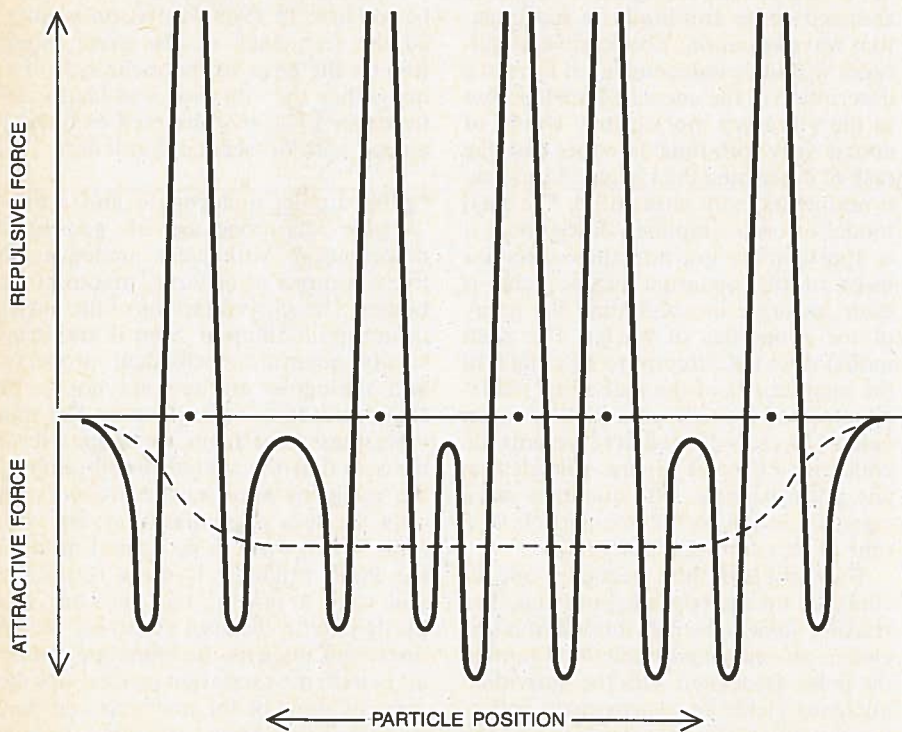

QUANTUM-MECHANICAL MODEL called the mean-field model provides a more satisfactory explanation of nuclear vibrations than models based on classical mechanics do. The force exerted on any one nucleon by the other nucleons in a nucleus fluctuates widely. Calculating the path of a nucleon in this field poses insurmountable difficulties. Not only is the field complex but also it changes rapidly because the nucleons creating the field are themselves in motion. The mean-field model simplifies the problem by postulating a smooth although varying field; it is the average of all the fluctuations of the actual field. An approximate mean field is calculated from the motion of the particles; the motion in turn is then calculated from the estimated field. Iterated calculations yield an approximation of the varying field that corresponds to the varying distribution of the nucleons during the vibration. The field shown here is for a one-dimensional array of nucleons; the actual distribution is a three-dimensional one.

ing of the vibrations on a deeper level. Protons and neutrons are no longer thought to be elementary particles; they are composite objects made up of the more fundamental particles called quarks. Any change in the nucleon's spin necessarily entails some change in the quarks' state of motion. The quark spins interact much more strongly than the nucleon spins and give the system a tendency to precess at a much higher frequency. The apparent number of spins vibrating at low frequency is thereby reduced.

The reduced participation in the Gamow-Teller vibration has consequences for astrophysics, particularly for the theory of supernovas. During the collapse of a star the nuclei in the core undergo inverse beta decay in which a proton, an electron and an antineutrino combine to form a neutron. The amount of energy available to blow off the outer layers of the star turns out to be proportional to the fraction of the nuclei that take part in the process. Because the nuclear species involved do not exist in the laboratory, one must rely on the theory of the spin vibrations in seeking an understanding of how stars explode.

The vibrational models and the mean-field theory have successfully accounted for the frequencies of the vibrations, but they do not explain one important aspect of the motion: the damping of the vibrations, the decrease in the amplitude and the final extinction of the motion with time. Experimentally the damping shows up as a broadening of the resonance peak in measurements of the vibrational frequency. From the width of a resonance, say 4 MeV for a typical dipole or quadrupole vibration, it can be calculated that the nucleus oscillates through about three cycles before the motion is damped out.

The mechanisms that underlie damping are poorly understood. Collisions between nucleons would damp out the motion quickly, but the Pauli exclusion principle severely limits the probability of such collisions. Indeed, the mean-field theory would not work as well as it does if collisions were frequent. Another possibility is that the vibrational motion is coupled to more complex patterns of motion in the nucleus. The mean-field theory, however, is not capable of dealing with complex, uncoordinated motions of the nucleons. These motions are of course present and show up as the background cross sections in most measurements. The question of vibrational damping and the search for a theoretical model that can treat the more complex motions are now among the most active areas of research. No doubt there is much remaining to be learned about vibrations of nuclei, and indeed about the cooperative motion of quantum particles in general.

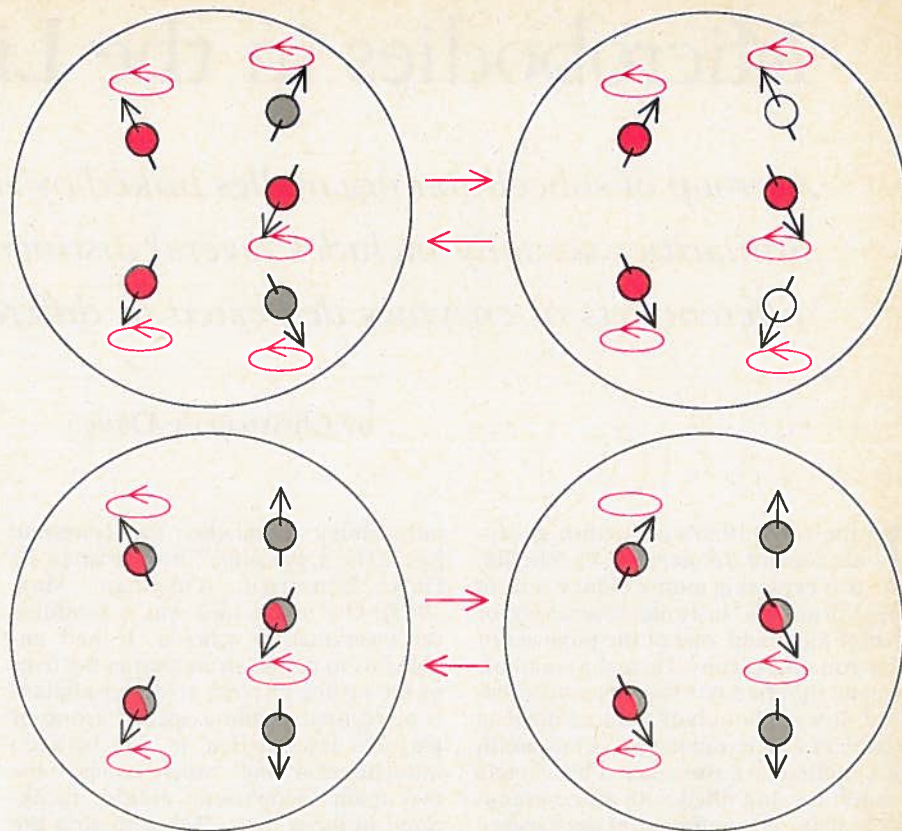

- PROTON
- NEUTRON
- PROTON CONVERTING INTO NEUTRON

GIANT SPIN VIBRATIONS represent the coordinated precession of the spin axes of the nucleons. In the giant magnetic-dipole resonance (top) a proton and a neutron are tipped in opposite directions; their spin axes precess 180 degrees out of phase with each other. As a result of the coordinated precession of a fraction of the nucleons the nucleus as a whole acquires a net spin and a net magnetic moment. In the giant Gamow-Teller resonance (bottom) a proton is converted into a neutron and its spin is tipped from the original orientation.

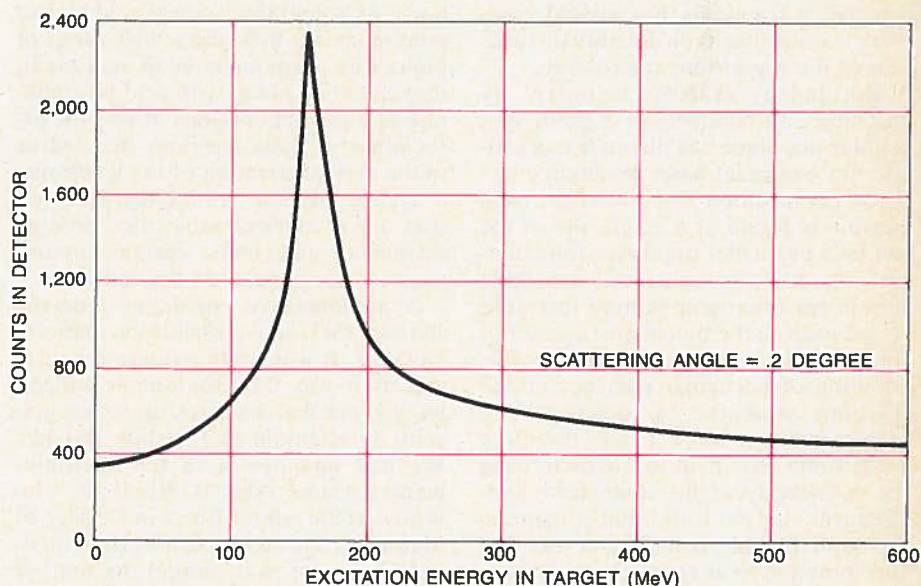

SCATTERING CROSS SECTION of the giant spin vibration is much like that of the giant monopole vibration, peaking at an angle close to zero degrees from the beam axis. The difference is that the projectile, a proton, exchanges electric charge with a neutron in the target nucleus in the course of exciting the vibration, so that the scattered particles are neutrons rather than protons. In this case protons with an energy of 160 MeV excite the giant spin vibration in lead nuclei and yield a diffracted beam of neutrons with an energy of 146 MeV. Because the neutrons are uncharged, it is easy to separate them from the beam protons and to measure scattering in the direction of the beam. The neutrons are not deflected by a magnetic field, however, and so their energy cannot be measured in a magnetic spectrograph. Instead their velocity is measured by timing their flight to a detector placed 100 meters away from the target.