

Double-Beta Decay from Several Perspectives

with N. Hinohara, J.D. Holt, M. Mustonen, P. Navratil, D. Shukla

August 19, 2013

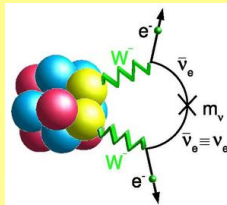

Importance of Neutrinoless Double Beta Decay

If it's observed, neutrinos are their own antiparticles!

and

Rate proportional to square of "effective mass":

$$m_{\text{eff}} \equiv \sum_{i=1}^3 m_i U_{ei}^2$$

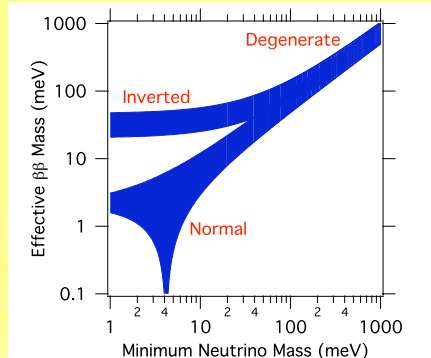
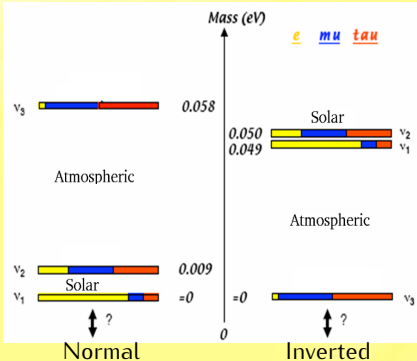

Importance of Neutrinoless Double Beta Decay

If it's observed, neutrinos are their own antiparticles!

and

Rate proportional to square of "effective mass":

$$m_{\text{eff}} \equiv \sum_{i=1}^3 m_i U_{ei}^2$$

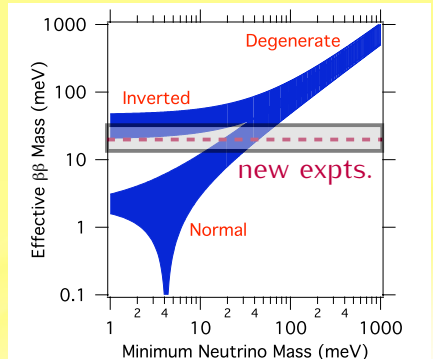
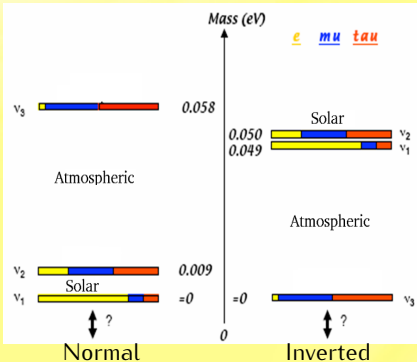

Rate also depends on a nuclear matrix element

Nuclear Matrix Element (Simplified)

$$M_{0\nu} = g_A^2 M_{0\nu}^{GT} - g_V^2 M_{0\nu}^F + \dots$$

with

$$M_{0\nu}^{GT} \approx \langle f | \sum_{a,b} \frac{1}{r_{ab}} \vec{\sigma}_a \cdot \vec{\sigma}_b \tau_a^+ \tau_b^+ | i \rangle$$

$$M_{0\nu}^F \approx \langle f | \sum_{a,b} \frac{1}{r_{ab}} \tau_a^+ \tau_b^+ | i \rangle$$

Lots of corrections to these expressions.

Recent Level of Agreement

Same level of agreement in 2013.

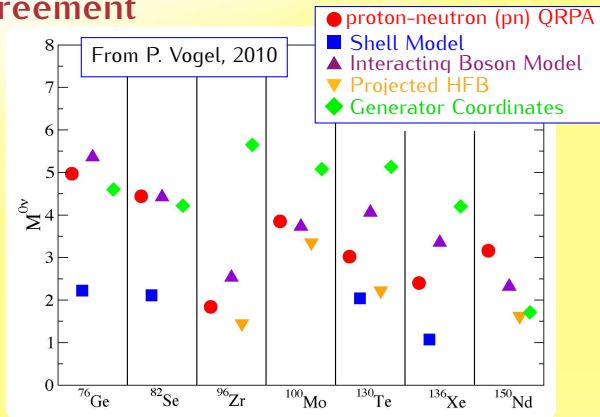

Calculations fall into two broad classes:

I. "Energy-Density-Functional Theory"

- ▶ Generator Coordinates
- ▶ QRPA
- ▶ ~~Projected HFB~~

II. Shell Model and derivatives

- ▶ Shell Model (Duh!)
- ▶ ~~IBM~~

Goal: Move each of these to next level

Contrasting the Various Approaches

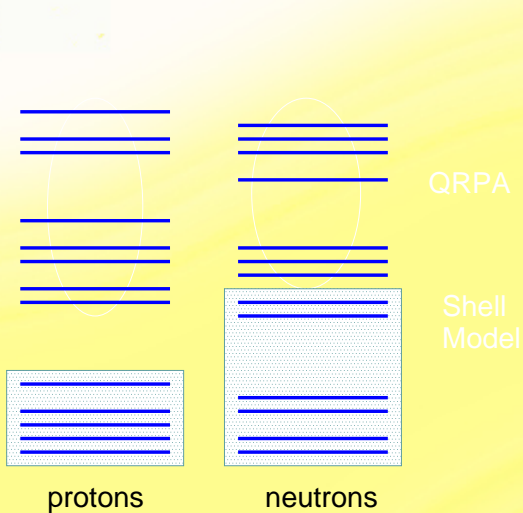

Contrasting the Various Approaches

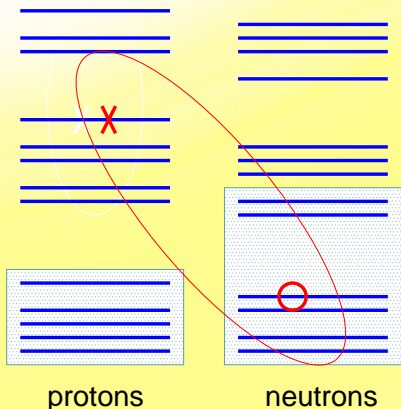

pn
QRPA

Sh
Mo

Mean-field+extension: Large single-particle spaces in arbitrary mean field or set of mean fields; simple correlations within the spaces (pn correlations here in QRPA).

Contrasting the Various Approaches

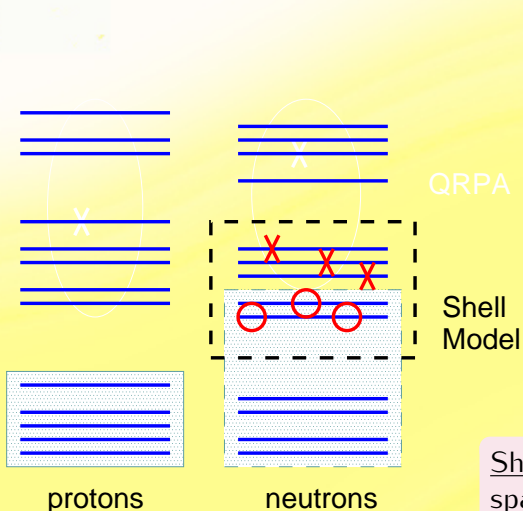

Shell Model: Small single-particle space in simple spherical mean field; arbitrarily complex correlations within the space.

Contrasting the Various Approaches

IBM is somewhere in between, mapping matrix elements from up to two shells but truncating to collective pairs.

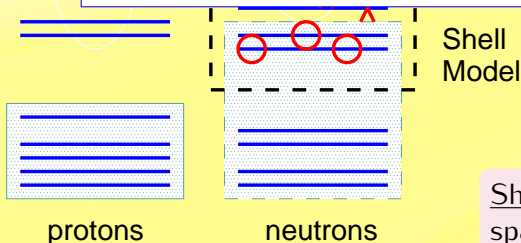

Shell Model: Small single-particle space in simple spherical mean field; arbitrarily complex correlations within the space.

First Large-Scale Deformed QRPA

QRPA inserts complete set of states in intermediate nucleus, provides single-beta matrix elements from ground states of initial and final nuclei to this complete set.

We converted like-particle deformed Skyrme matrix QRPA to proton-neutron channel. Used Skyrme functional SkM*, consumed $\approx 7\text{M}$ CPU hours.

Worth mentioning:

QRPA gives two sets of energies and strengths (but not wave functions) for intermediate-nucleus states. Doesn't tell you how these two sets are related.

Must finesse the problem (i.e. cheat).

Sensitivity to Proton-Neutron Pairing

Have to do usual tuning of g_{pp} . Can cover up of virtues as well as sins.

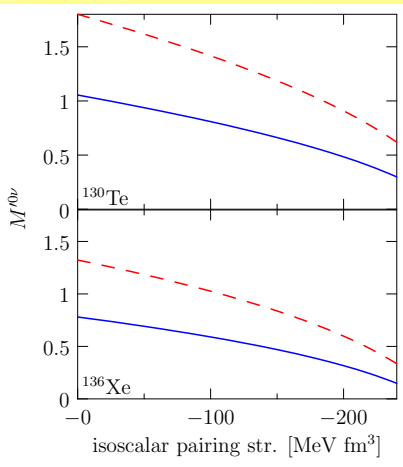
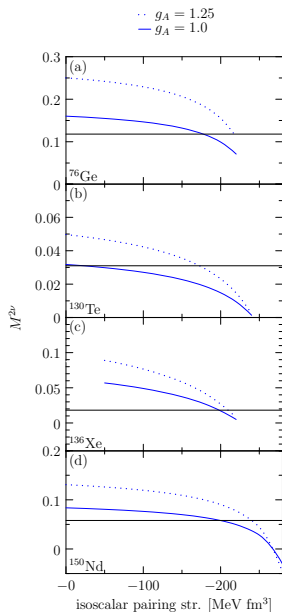

Results

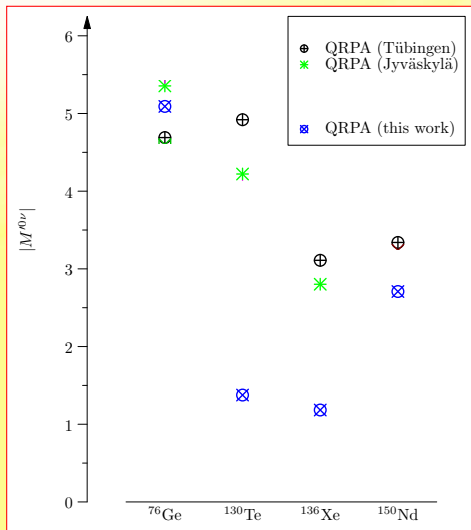

Results different from other QRPA in some nuclei, but this actually points to problems with method.

The QRPA has Some Issues...

Some of the nuclei in these decays don't have well defined shape.

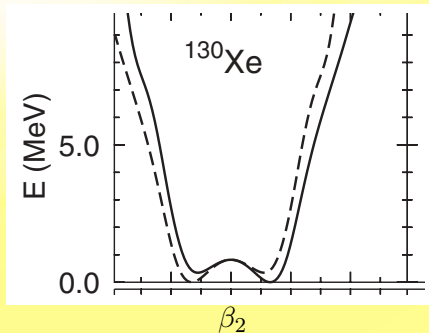

Robledo et al.: Energy minima at $\beta_2 \approx \pm 0.15$

Solid line is actual result;
dashed line a symmetric potential for comparison

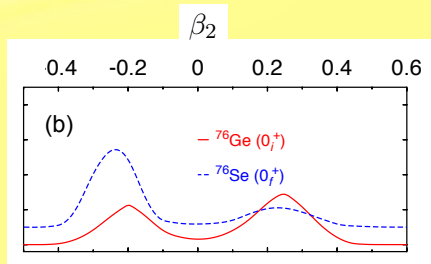

Rodríguez and Martínez-Pinedo: Wave functions peaked at $\beta_2 \approx \pm 0.2$

Beyond QRPA

Want to avoid the problems:

1. Overlap of intermediate states not well defined
2. No mixing of mean fields with different shapes, pairing...
3. Simplicity of correlations
4. **Unrealistically strong response to proton-neutron pairing**
(as phase transition to pn pairing is approached)?

For 0ν decay we only need ground state. **Generator-coordinate method** takes advantage of that, and avoids problems 1, 2, and (to some extent) 3.

We're generalizing it to include proton-neutron pairing and spin-isospin correlations, deal with problem 4.

Rodríguez et al Generator-Coordinate Calculation

Basic idea: Construct set of mean fields by constraining coordinate(s), e.g. quadrupole moment $\langle Q_0 \rangle$. Minimize

$$\langle H' \rangle = \langle H \rangle - \lambda \langle Q_0 \rangle$$

Then use $\langle Q_0 \rangle$ as a collective coordinate; diagonalize H in space of number- and angular-momentum-projected quasiparticle vacua with different values of $\langle Q_0 \rangle$.

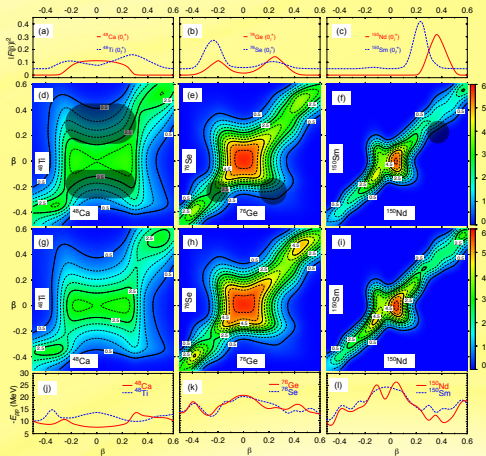

Rodríguez and Martínez-Pinedo

Adding pn Correlations to GCM

GCM results missing physics that affects QRPA calculations.

So we generalize the approach:

1. Pairing currently treated as mean field, but not pn pairing. So we construct quasiparticles that mix not only particles and holes, **but also neutrons and protons.**
2. Constrain proton-neutron pairing and particle-hole condensation as well as deformation, i.e. minimize

$$H' = H - \lambda_Q \langle Q_0 \rangle - \lambda_P \langle P_0^\dagger \rangle - \lambda_{\sigma\tau} \langle O_{\sigma\tau} \rangle$$

with

$$P_0^\dagger = \sum_l \left[a_l^\dagger a_l^\dagger \right]_{M_S=0}^{L=0, S=1, T=0}, \quad O_{\sigma\tau} = \sum_i \sigma_z(i) (\tau^+(i) + \tau^-(i))$$

The pn operators have zero expectation value at HFB minimum, but we add quasiparticle vacua with non-zero values.

Test in Solvable SO(8) Model

Consider many degenerate oscillator levels with orbital angular momentum l :

Pairing Operators

Usual spin-singlet pair operators

pn (spin-triplet) pair operators

$$S_{\nu}^{\dagger} = \sum_l \left[a_l^{\dagger} \tilde{a}_l \right]_{M_T=\nu}^{L=-0, S=0, T=1}$$

$$P_{\mu}^{\dagger} = \sum_l \left[a_l^{\dagger} \tilde{a}_l \right]_{M_S=\mu}^{S=1, T=0}$$

Hamiltonian is

$$H = -\frac{1+x}{2} \sum_{\nu} S_{\nu}^{\dagger} S_{\nu} - \frac{1-x}{2} \sum_{\mu} P_{\mu}^{\dagger} P_{\mu} + g_{ph} \sum_{ij} \vec{\sigma}_i \vec{\sigma}_j \vec{\tau}_i \vec{\tau}_j$$

Competition between ordinary pairing and spin-triplet pairing.

SO(8) Results

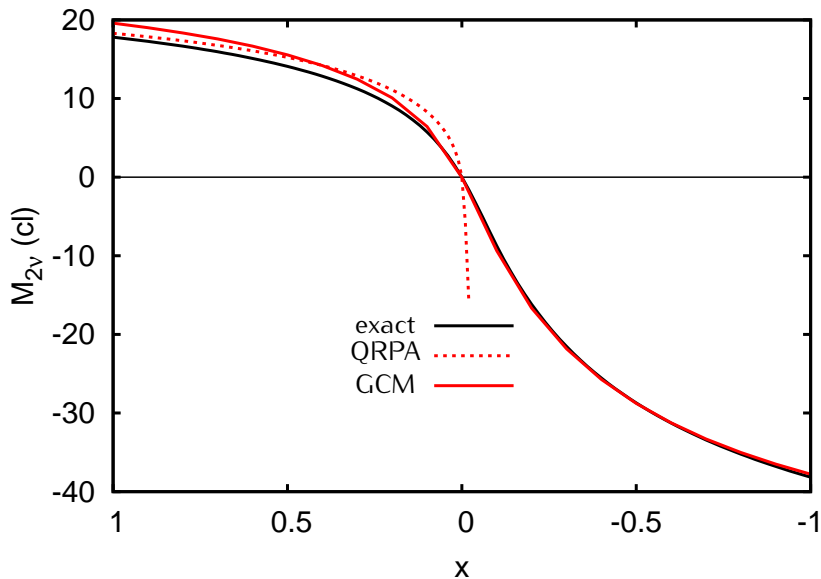

Calculation in *fp* + *sdg* Shells

H contains quadrupole-quadrupole, isovector/isoscalar pairing, and $\sigma\tau\sigma\tau$ interactions. Reproduces 2^+ levels in, e.g., ^{76}Se .

Total β^+ strength in ^{96}Pd (closed neutron shell)

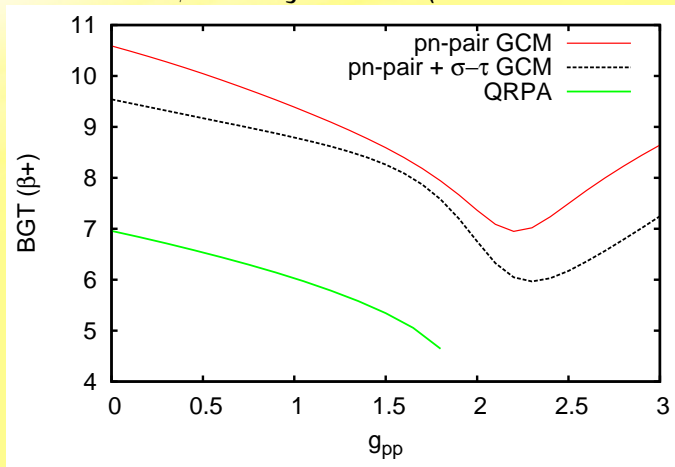

Ordinary GCM would give about 11 here.

Deformation Distributions for $A = 76$

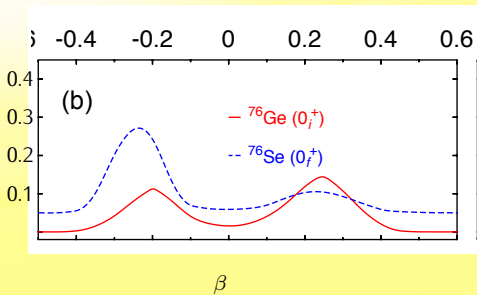

Rodríguez and Martínez-Pinedo

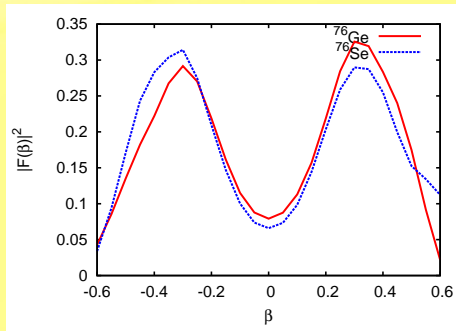

Hinohara

0ν Decay of ^{76}Ge

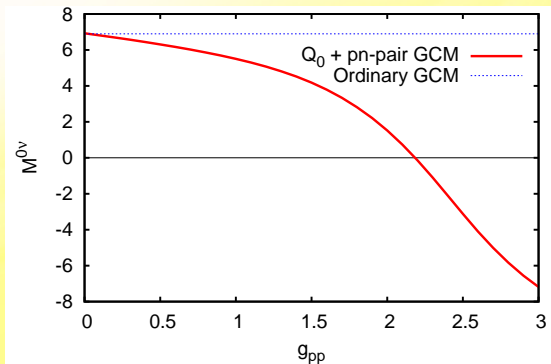

We still need to:

1. Add $\sigma\tau$ coordinate and improve its treatment. Currently leave out Fock terms. We're adding them and trying $S(\beta^+)$ as particle-hole coordinate. But may have to get fancier.
2. Determine appropriate value for g_{pp} .

After that: Add proton-neutron physics to Gogny- or Skyrme-based GCM.

Corrected Shell Model

Partition of Full Hilbert Space

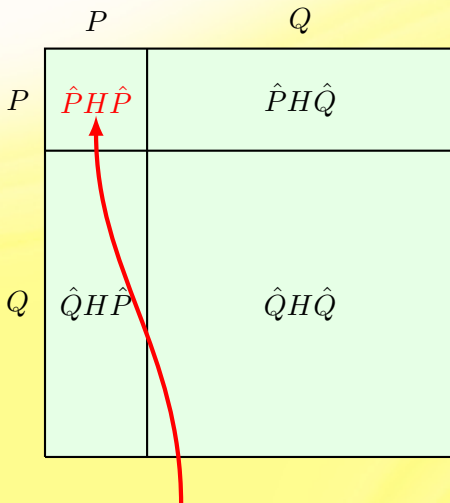

Shell model done here

P = valence space

Q = the rest

Task: Find unitary transformation to make H block-diagonal in P and Q , with H_{eff} in P reproducing d most important eigenvalues.

Corrected Shell Model

Partition of Full Hilbert Space

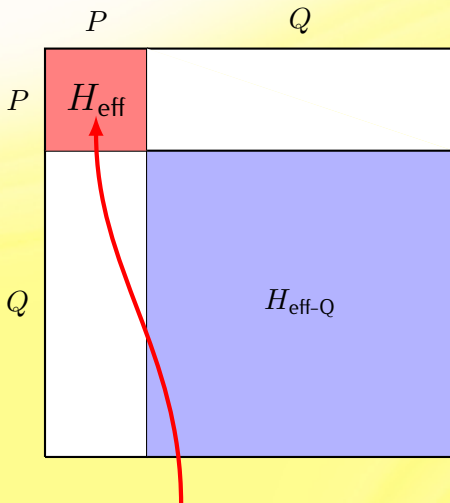

Shell model done here

P = valence space

Q = the rest

Task: Find unitary transformation to make H block-diagonal in P and Q , with H_{eff} in P reproducing d most important eigenvalues.

For transition operator \hat{M} , must apply same transformation to get \hat{M}_{eff} .

Corrected Shell Model

Partition of Full Hilbert Space

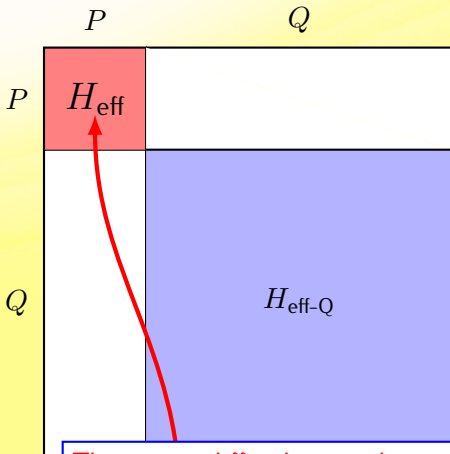

P = valence space

Q = the rest

Task: Find unitary transformation to make H block-diagonal in P and Q , with H_{eff} in P reproducing d most important eigenvalues.

For transition operator \hat{M} , must apply same transformation to get \hat{M}_{eff} .

This is as difficult as solving full problem. But the idea is that N-body effective operators may not be important for $N > 2$ or 3.

Shell model done here

Perturbation-Theory Approach

Q-Box

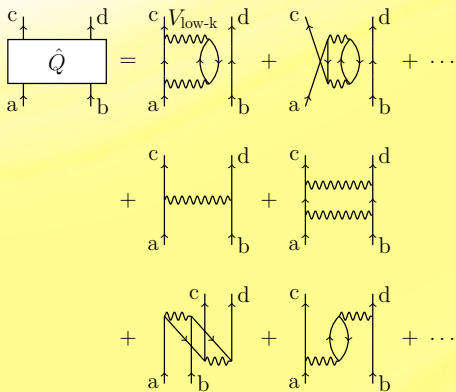

X-Box

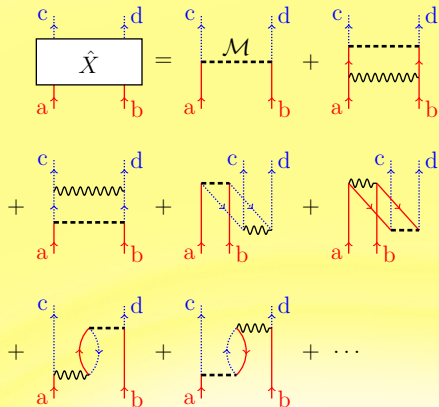

Equation for Effective Transition Operator

$$\begin{aligned} \langle cd | \mathcal{M}_{\text{eff}} | ab \rangle = & \\ & \left(\left[1 + \frac{1}{2} \frac{d\hat{Q}(\varepsilon)}{d\varepsilon} + \frac{1}{2} \frac{d^2\hat{Q}(\varepsilon)}{d^2\varepsilon} \hat{Q}(\varepsilon) + \frac{3}{8} \left(\frac{d\hat{Q}(\varepsilon)}{d\varepsilon} \right)^2 \dots \right] \right. \\ & \times \left[\hat{X}(\varepsilon) + \hat{Q}(\varepsilon) \frac{\partial \hat{X}(\varepsilon_f, \varepsilon)}{\partial \varepsilon_f} \Big|_{\varepsilon_f = \varepsilon} + \frac{\partial \hat{X}(\varepsilon, \varepsilon_i)}{\partial \varepsilon_i} \Big|_{\varepsilon_i = \varepsilon} \hat{Q}(\varepsilon) \dots \right] \\ & \left. \times \left[1 + \frac{1}{2} \frac{d\hat{Q}(\varepsilon)}{d\varepsilon} + \frac{1}{2} \frac{d^2\hat{Q}(\varepsilon)}{d^2\varepsilon} \hat{Q}(\varepsilon) + \frac{3}{8} \left(\frac{d\hat{Q}(\varepsilon)}{d\varepsilon} \right)^2 \dots \right] \right)_{cd,ab} \end{aligned}$$

Perturbative Effective Decay Operator

Evaluated $\beta\beta$ version of these (which are for effective interaction).

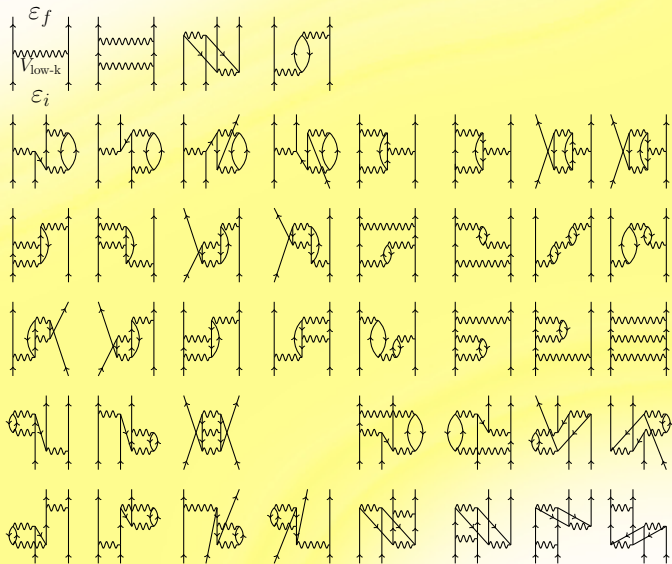

Perturbative Effective Decay Operator

Evaluated $\beta\beta$ version of these (which are for effective interaction).

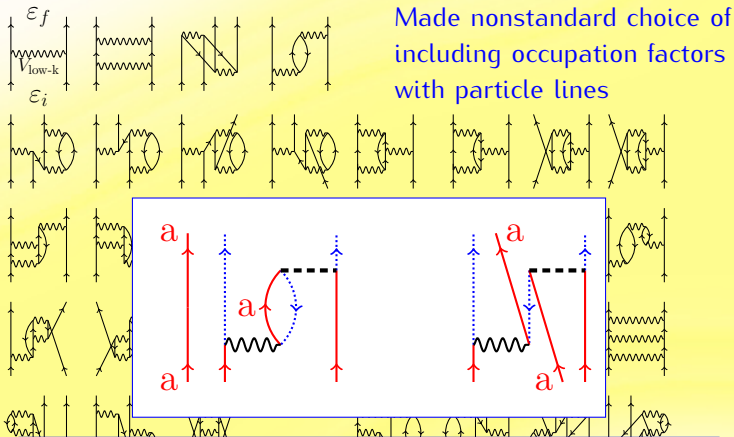

Three-body diagram on right (which we don't include) would cancel diagram on left in multiparticle system. Our prescription removes diagram on left.

Results

See Jason's talk next!

Can we really believe the results? Convergence is an issue, but a deeper one may be effect of many-body induced operators.

Nonperturbative Test

Perturbation theory still may not be perfect so we also try to do without it.

So far, have just tested in p shell:

- ▶ Do pseudo-exact (6 or 8 $\hbar\omega$) no-core calculations for ${}^5\text{He}$, ${}^5\text{Li}$, get p -shell single-particle energies
- ▶ Do the same for ${}^6\text{He}$, ${}^6\text{Be}$, get effective p -shell two-body interaction, effective two-body $\beta\beta$ operator.
- ▶ Use those operators to calculate ${}^{7,8,10}\text{He} \rightarrow {}^{7,8,10}\text{Be}$. Test adequacy of two-body operator. Can do the same for 3-body Hamiltonian and decay operator.

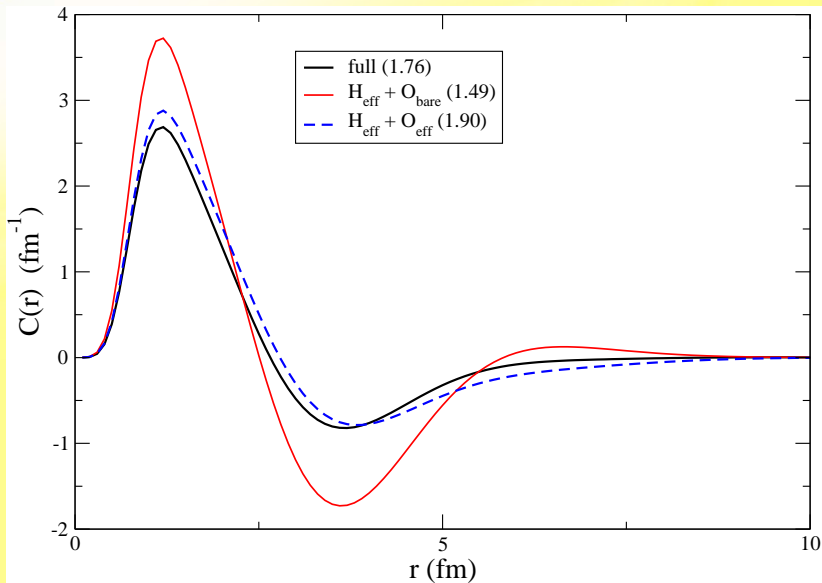

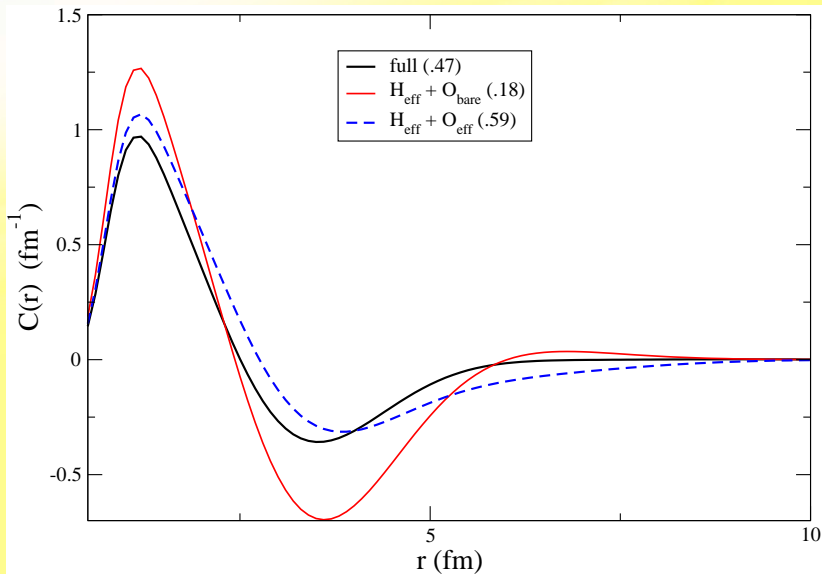

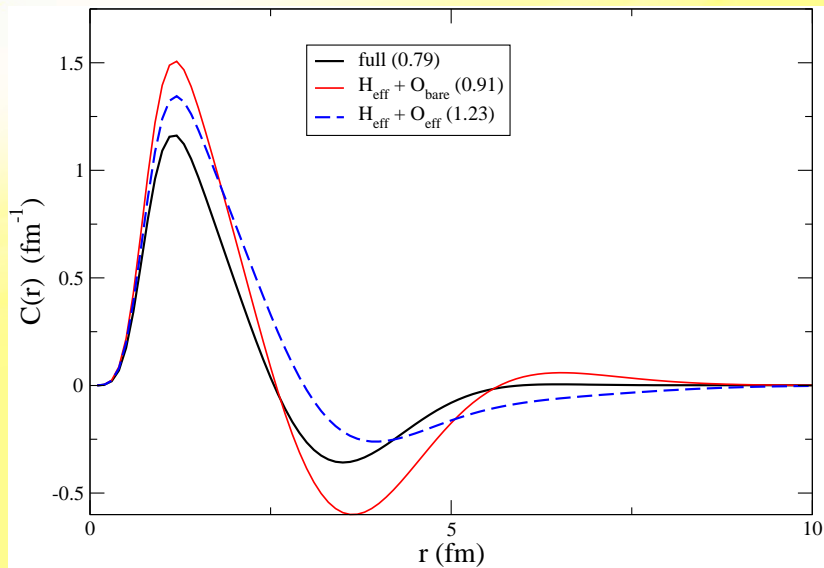

Want to test improvement from three-body operators.

Nonperturbative Future

- ▶ **Coupled Clusters:** Solve the two-particle attached problem (closed shell + 2) on top of e.g., ^{56}Ni and three-particle-attached in some approximation, do Lee-Suzuki mapping of lowest eigenstates onto $f_{5/2}pg_{9/2}$, determine effective Hamiltonian and decay operator (up to three-body), calculate matrix element for ^{76}Ge . Janssen and Hagen already working on this.
- ▶ **In-Medium SRG:** Hergert, Bogner, et al have published preliminary results for effective interaction in sd shell. Should be able to extend procedure to decay operator and $f_{5/2}pg_{9/2}$ shell.

Issue Facing All Models: “ g_A ”

Forty(?)–year old problem: Single-beta rates, 2ν double-beta rates, related observables overpredicted in heavy nuclei.

Typical solution: “Renormalize” g_A to get correct results. But if g_A is renormalized by same amount in 0ν decay as in 2ν decay (a lot in shell model), experiments will fail; rates go as $(g_A)^4$.

Better solution: Understand reasons for overprediction. In modern language, must be due to

1. Many-body weak currents, either modeled as in GFMC or from chiral EFT.

Who’s right? The many old-school practitioners who say meson-exchange effects are small, or the chiral-EFT folk, who say they can be large?

2. Truncation of model space, to be fixed in shell model as already discussed. Can treat “bare many-body” operators as well.

Issue Facing All Models: “ g_A ”

Forty(?)–year old problem: Single-beta rates, 2ν double-beta rates, related observables overpredicted in heavy nuclei.

Typical solution: “Renormalize” g_A to get correct results. But if g_A is renormalized by same amount in 0ν decay as in 2ν decay (a lot in shell model), experiments will fail; rates go as $(g_A)^4$.

Better solution: Understand reasons for overprediction. In modern language, must be due to

1. Many-body weak currents, either modeled as in GFMC or

People are attacking both sides of this problem.

2. Truncation of model space, to be fixed in shell model as already discussed discussed. Can treat “bare many-body” operators as well.

So...

Se should be able to improve nearly all methods for treating double-beta decay.

Future is ~~bright~~ not at all dim.

That's all.