

Quantum Information and Quantum Computing for Fundamental Physics



National Nuclear Physics Summer School 2026

Seattle, WA

June 29 - July 11, 2026

Martin Savage
InQubator for Quantum Simulation
University of Washington

Part-1,2:
Complexity in Fundamental Physics

We are entering a transformational period for advanced technologies to accelerate research in Fundamental Science

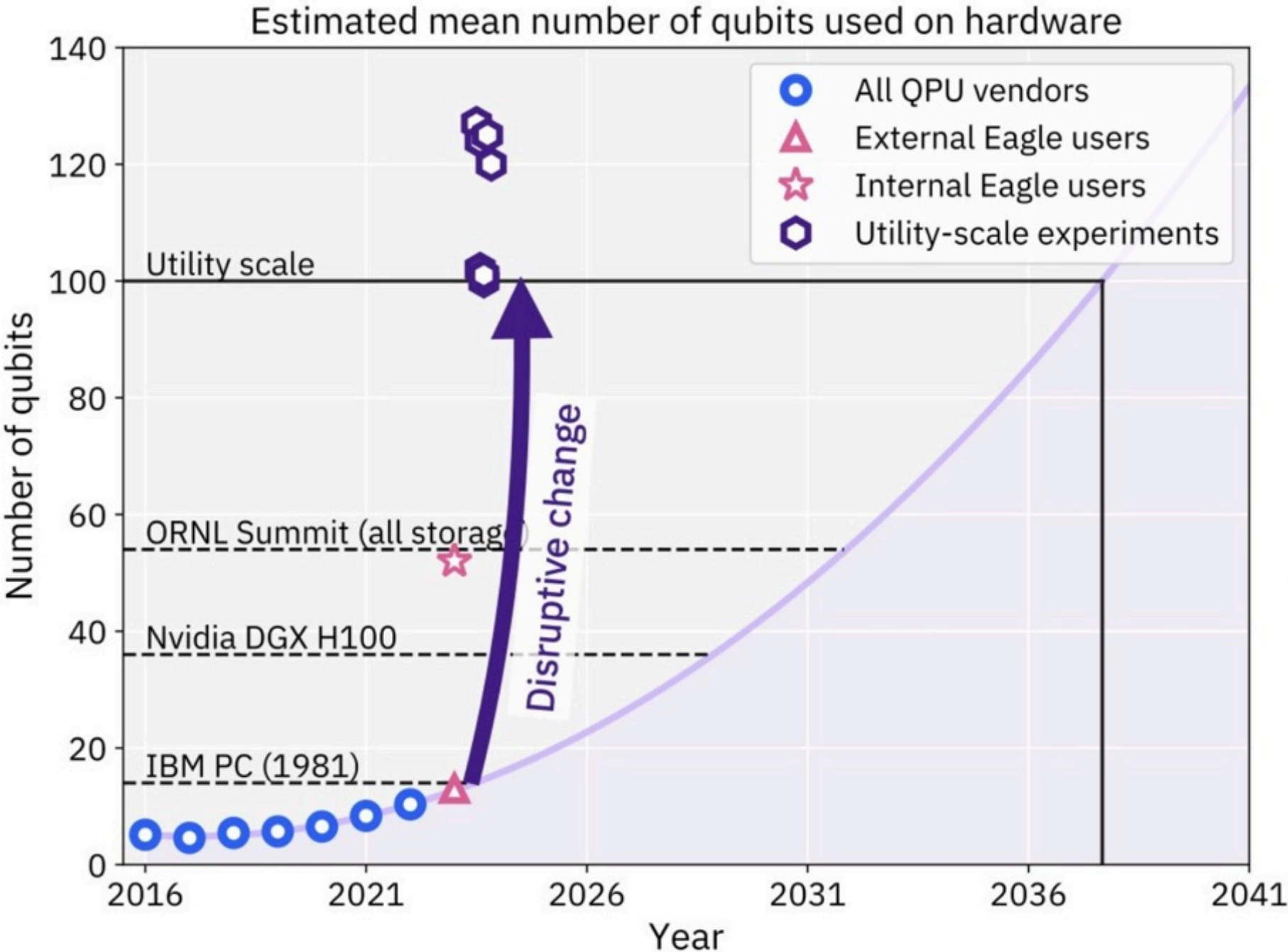

IBM Quantum

- QIS, quantum computing and AI will enable researchers to progress toward our priorities in FS
- Universities, national labs and tech. companies together
- FS is finely-tuned and a balance between classical and quantum, massive range of energy scales.

- Quantum simulations are advancing, heading into 2+1D
- Evolution from NISQ to fault tolerant/error correcting
- Understanding quantum complexity

Department of Energy Road Map

Energy Department Announces Initiative to Create and Deploy the World's First Scientifically Relevant, Fault-Tolerant Quantum Computers

June 23, 2026

WASHINGTON—The U.S. Department of Energy (DOE) today announced the establishment of the ambitious new Quantum Genesis initiative to develop and deploy the world's first fault-tolerant, scientifically relevant quantum computing capability for research and development by 2028. The Quantum Genesis effort will serve as a foundational element of the broader Genesis Mission, designed to usher in a new era of computational power for the nation to accelerate scientific discovery and innovation.

InQubator for Quantum Simulation



IQuS InQubator for Quantum Simulation

**Workshops
Research
Visitors**



TO ACCELERATE PROGRESS IN QIS, QFT AND QMB SYSTEMS

IQuS InQubator for Quantum Simulation

Co-design for Fundamental Physics in the Fault-Tolerant Era

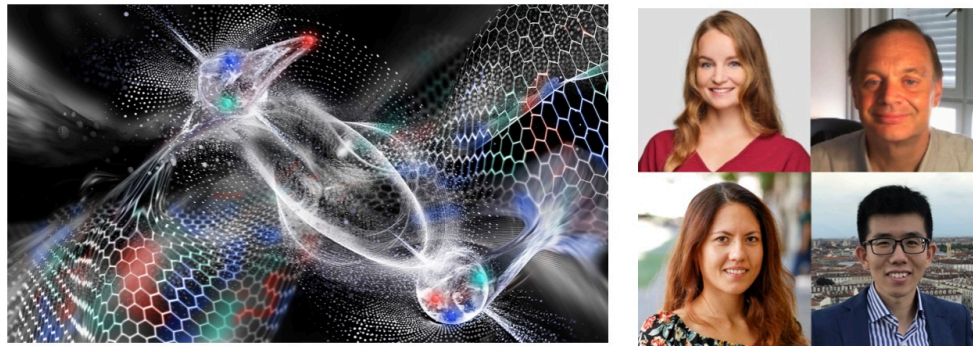

Organizers:
Elisa Baumer (IBM, Zurich) **Francesco Pederiva (Trento)**
Federica Surace (Caltech) **Xiaojun Yao (UW)**

<https://iqus.uw.edu/events/iqus-workshop-2025-1/>

IQuS InQubator for Quantum Simulation

2nd International Workshop on Many-Body Quantum Magic



Organizers:
Tobias Haug (Abu Dhabi) **Caroline Robin (Bielefeld)**
Emanuele Tirrito (Trieste) **Xhek Turkeshi (Cologne)**

2024: Abu Dhabi; 2025: Seattle.

<https://iqus.uw.edu/events/iqus-workshop-2025-2/>

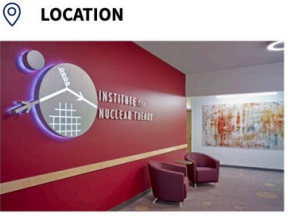

LOCATION
Institute for Nuclear Theory Pacific and 15th

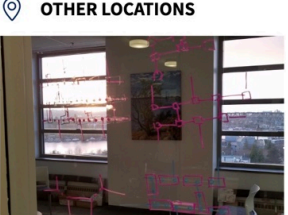

OTHER LOCATIONS
IQuS University of Washington PHYS/ASTR Building, Seattle, WA 98195



Katie Hennessey

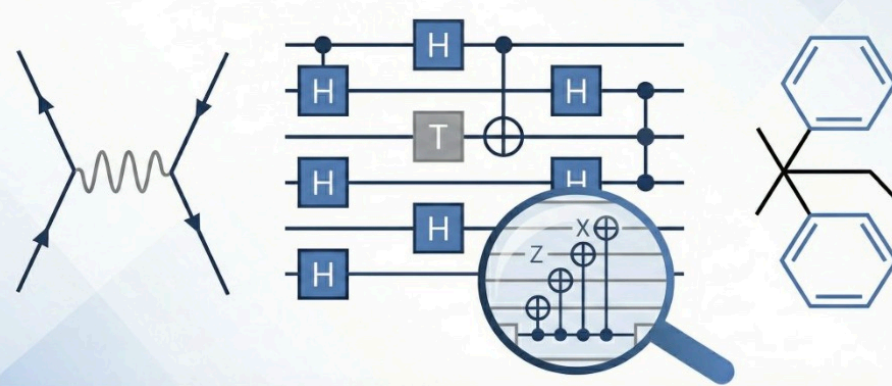
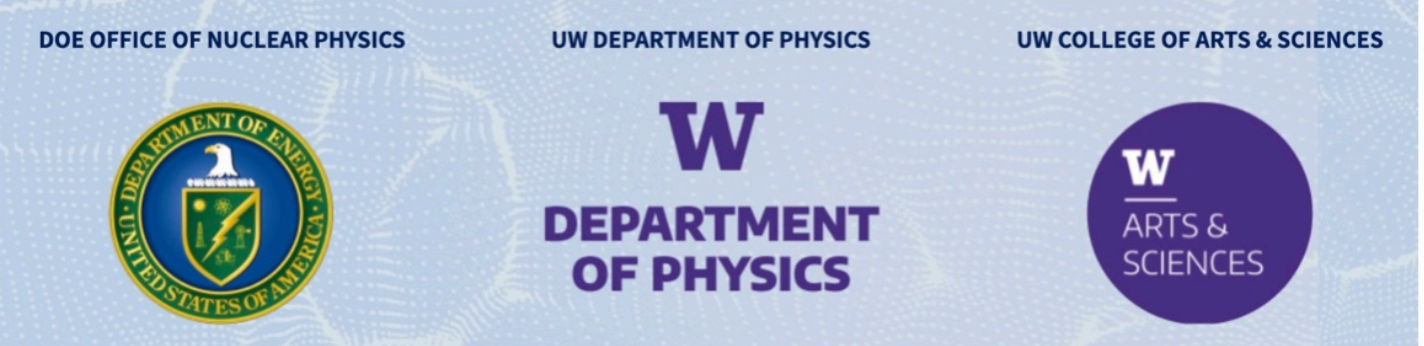

Part-2

Quantum Complexity

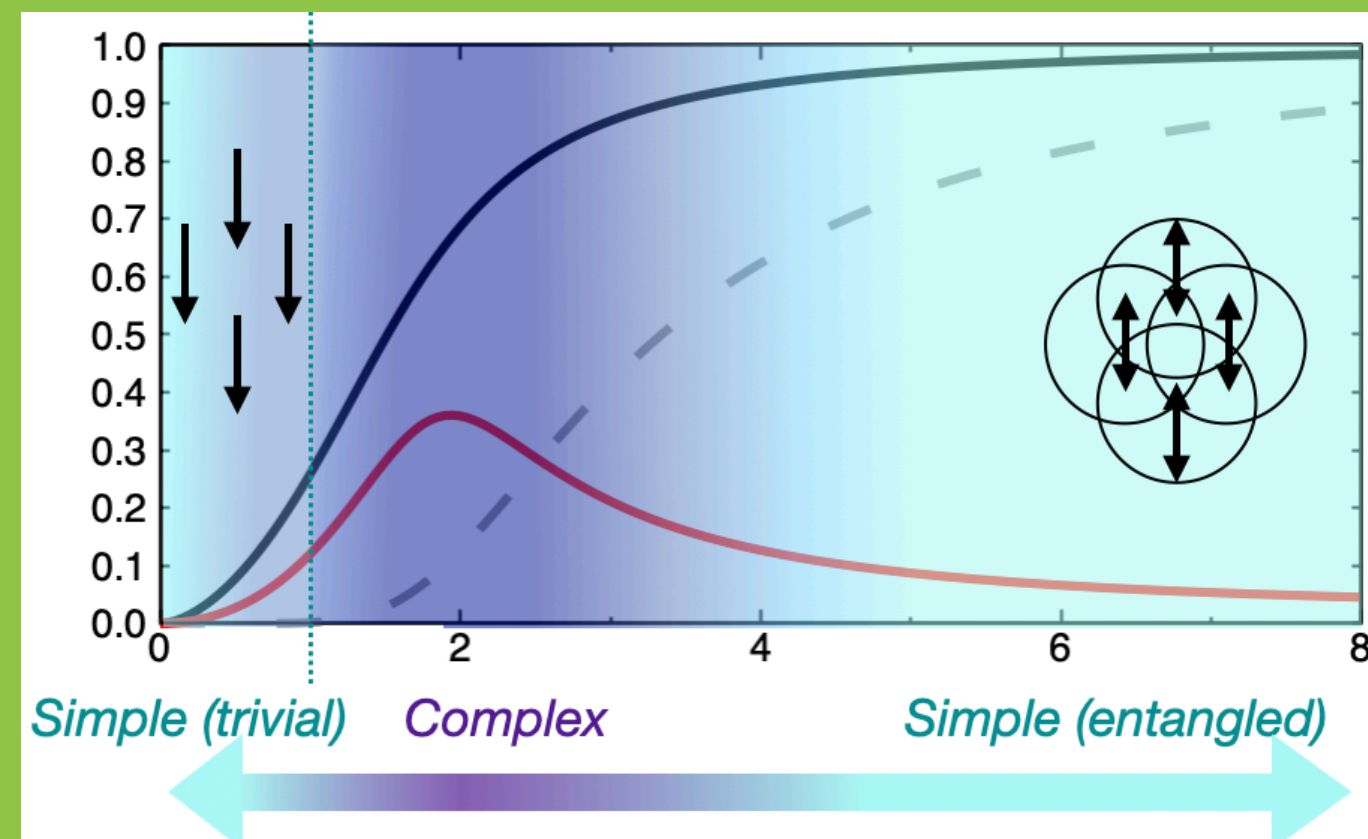

Part-3

Quantum Computing and Simulation

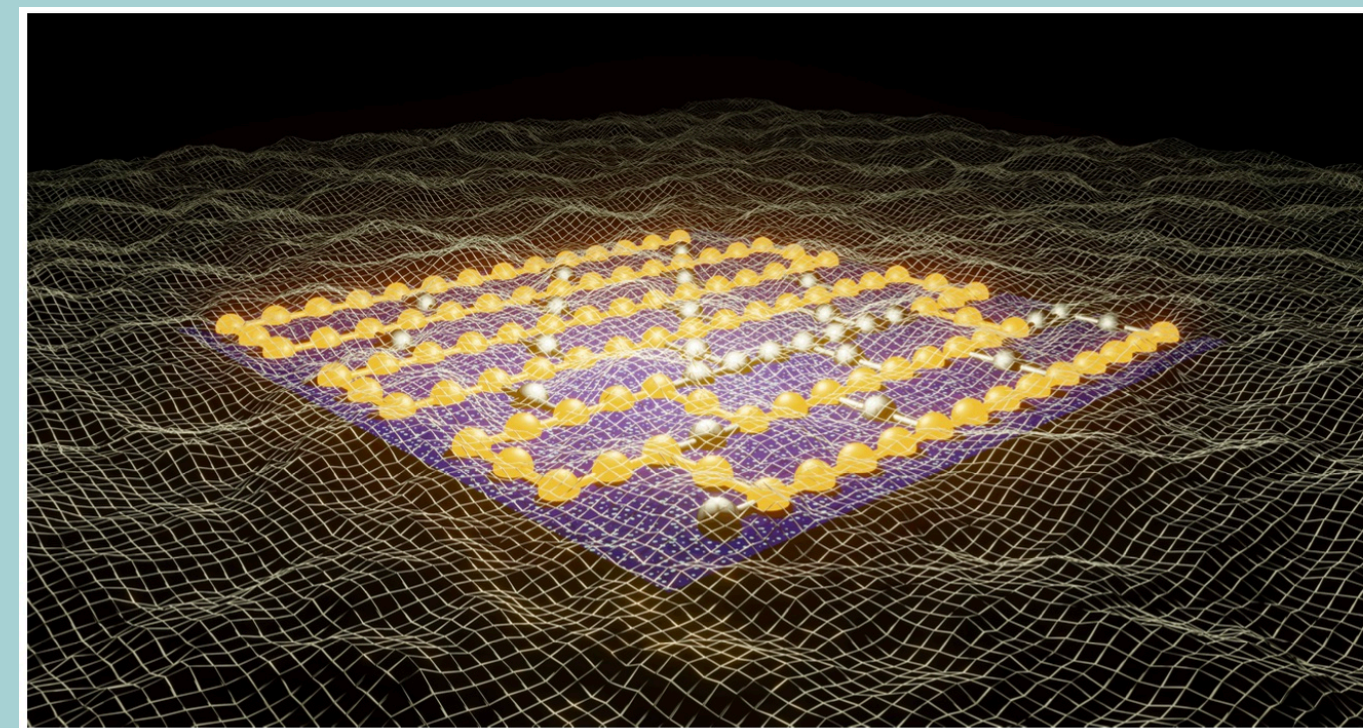

Part-4

Beyond NISQ and Beyond Qubits

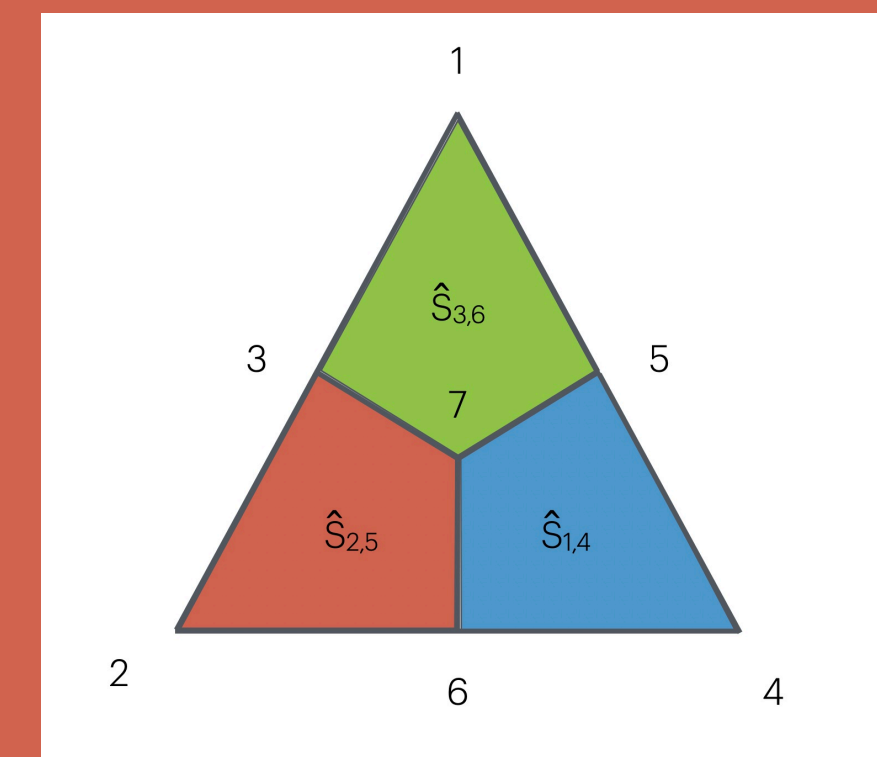

Part-1

Introduction to Quantum
Information in Fundamental
Physics

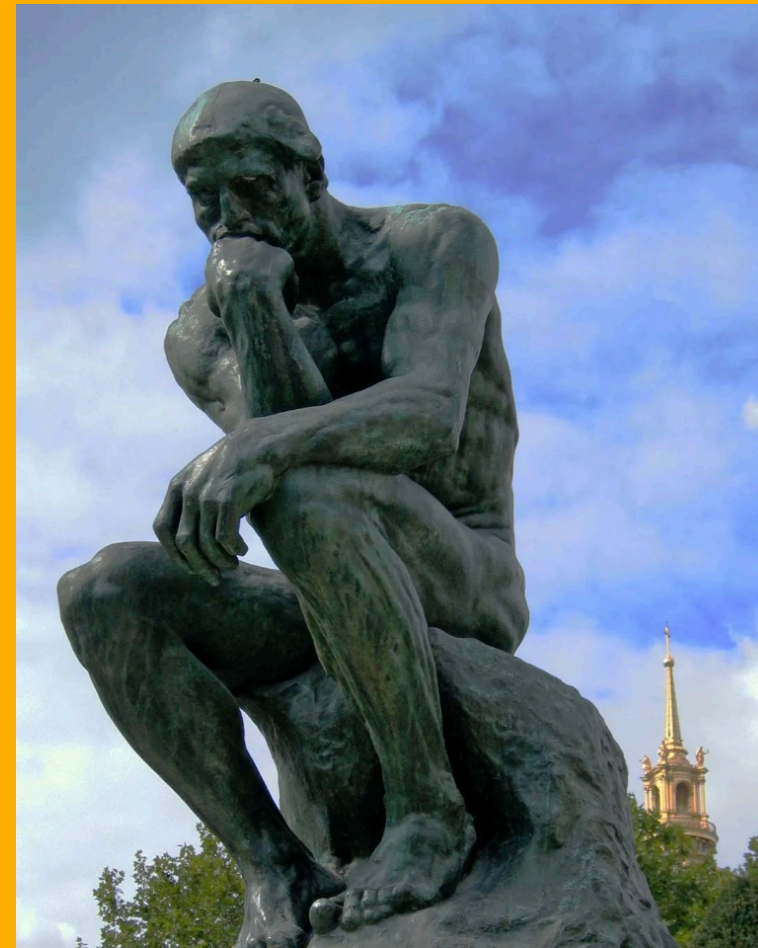

Particles & Interactions

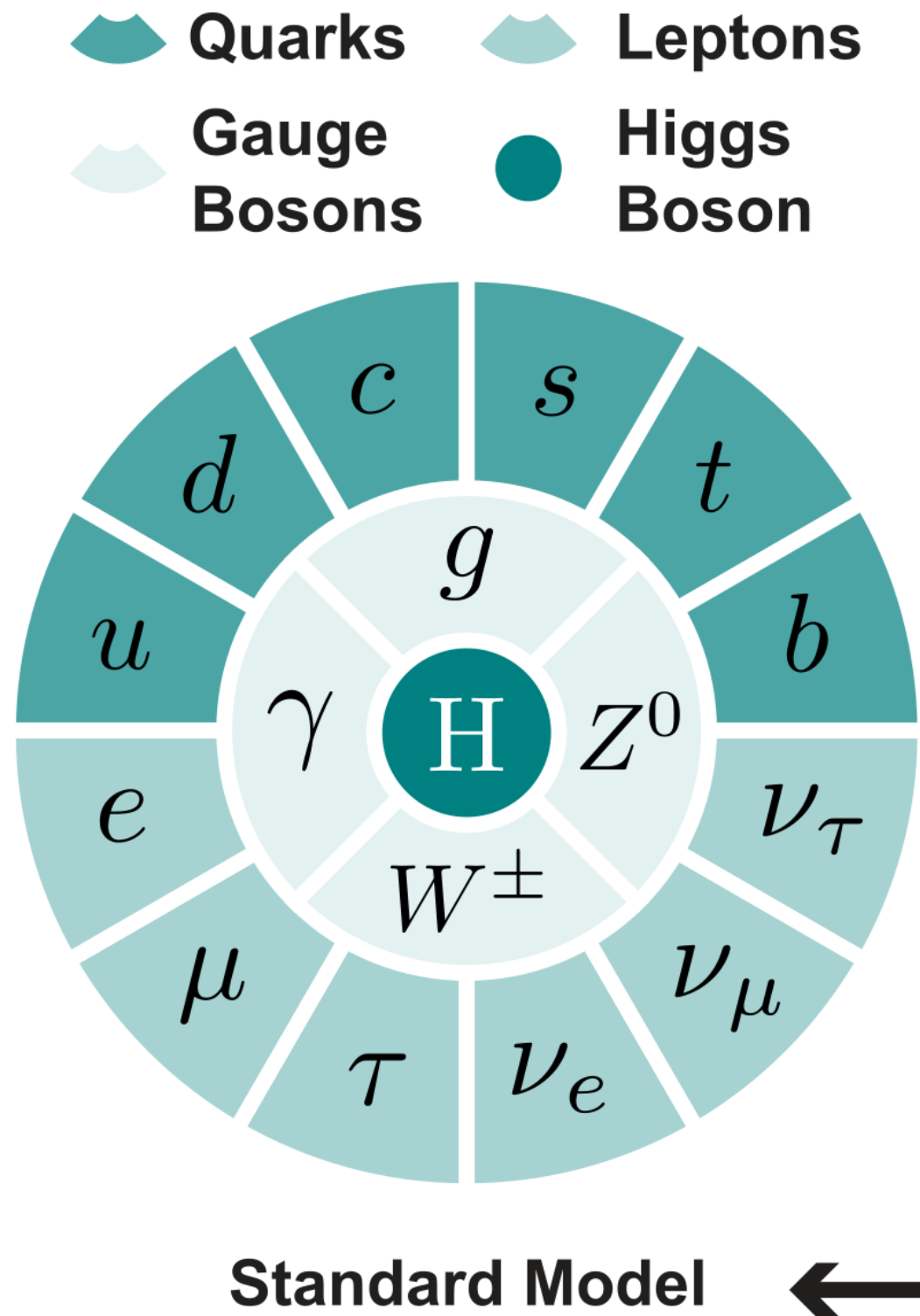

Simulation

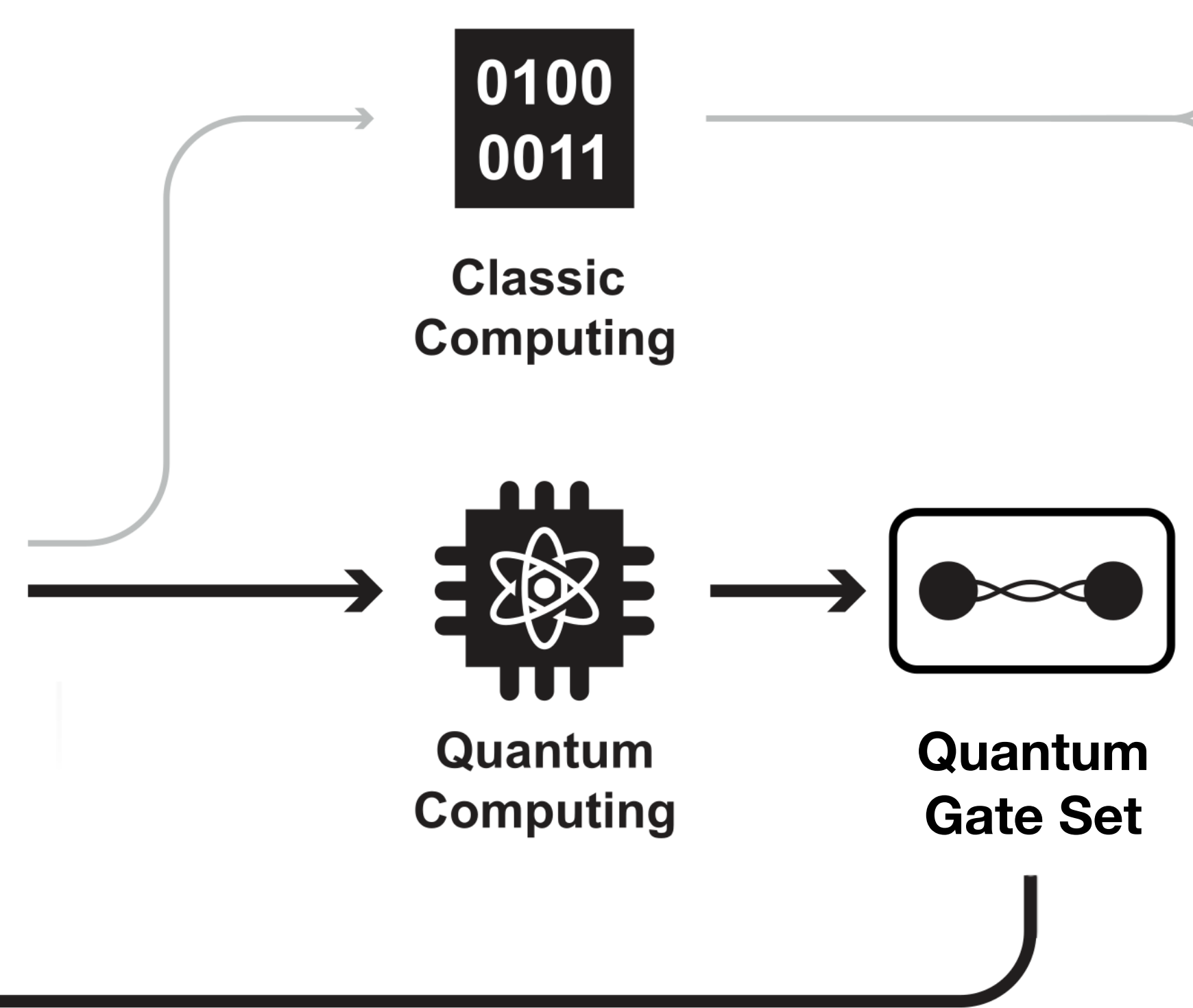

Phases & Dynamics of Matter

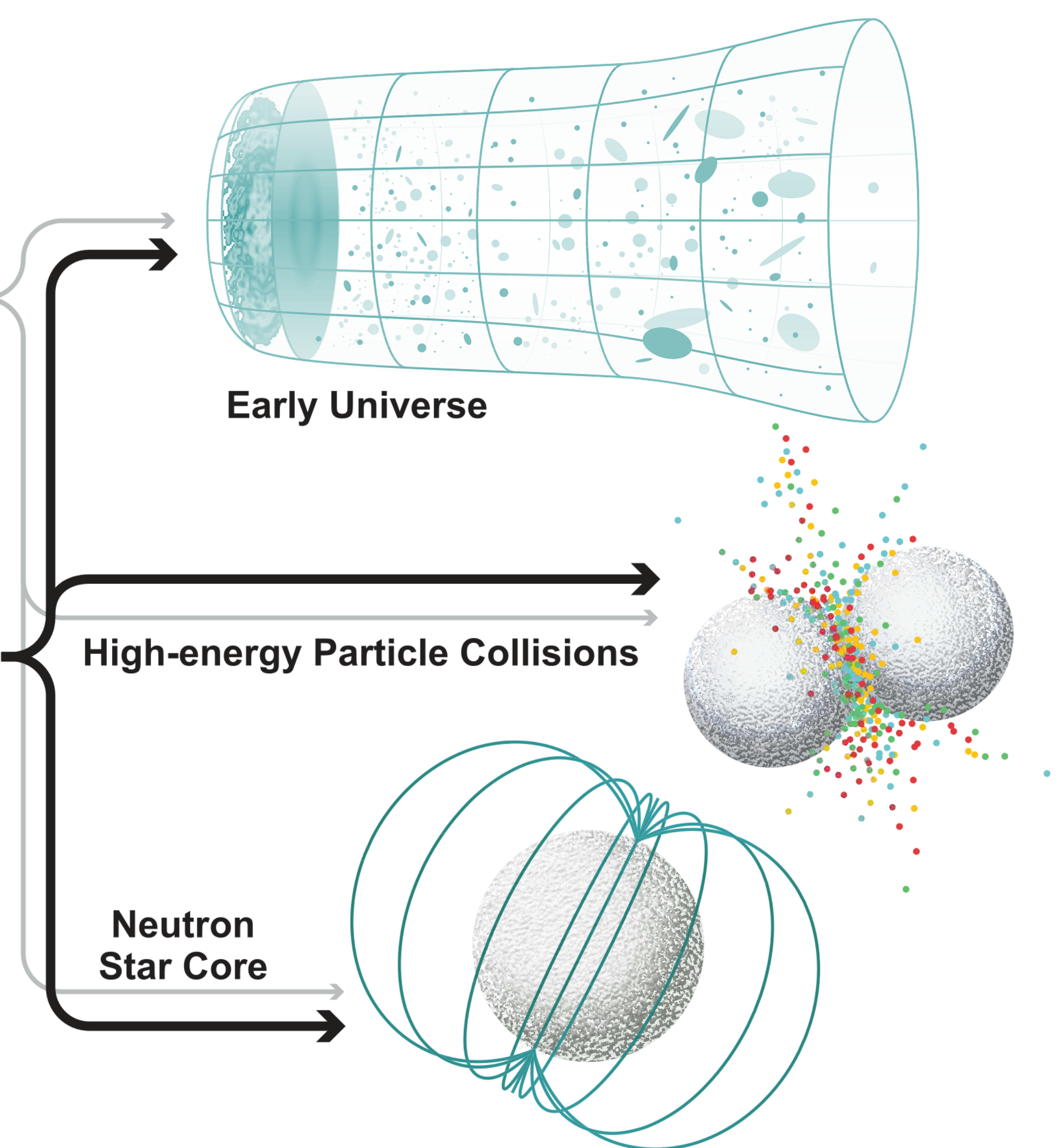

Perspective | Published: 21 June 2023

Quantum simulation of fundamental particles and forces

Christian W. Bauer, Zohreh Davoudi, Natalie Klco & Martin J. Savage

Nature Reviews Physics 5, 420–432 (2023) | Cite this article

Decades of High Performance Computing experience

- Physics-Aware Algorithms and Hardware (into the peta-scale)

Ordinary Matter

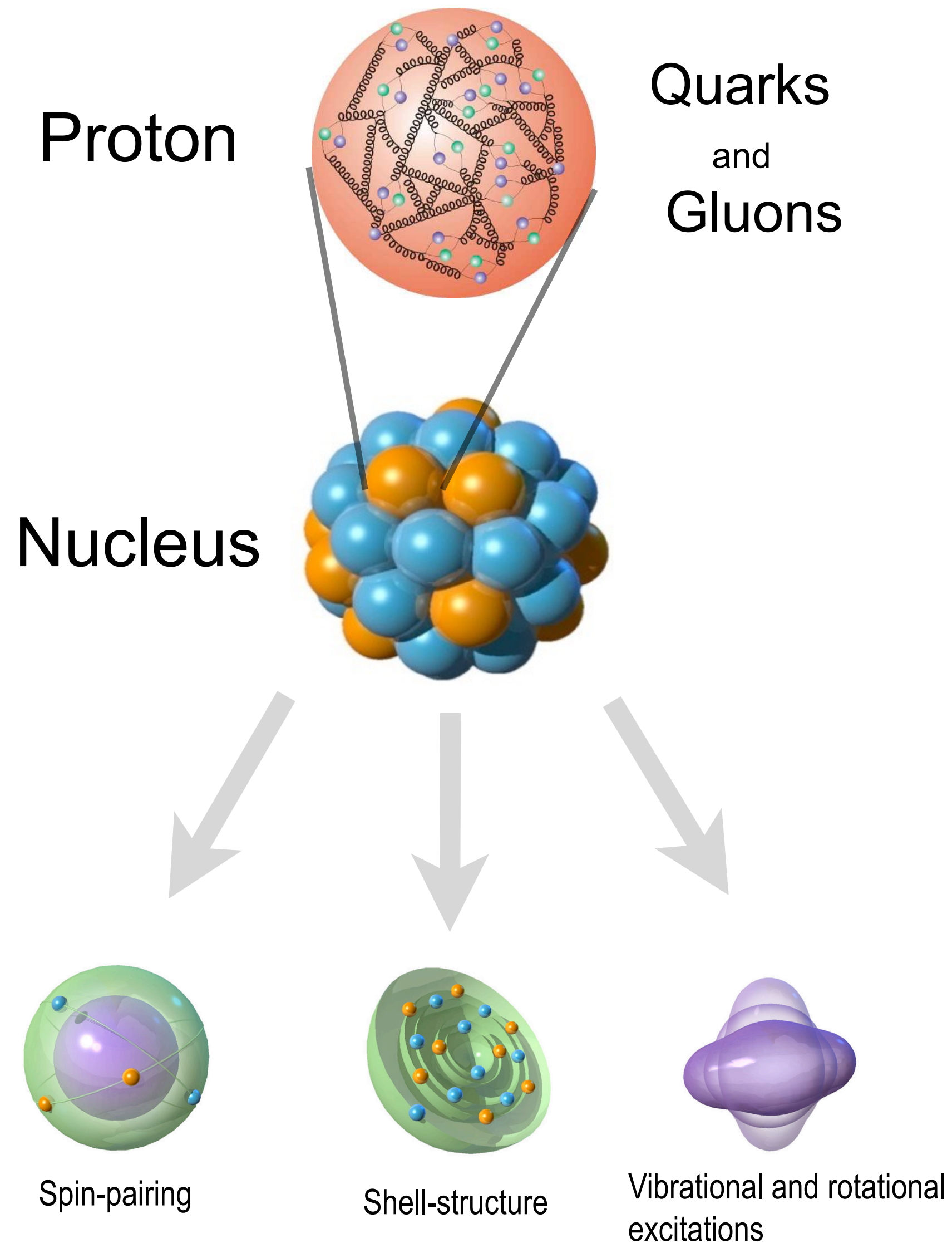

$$\frac{m_u}{\Lambda_{\text{QCD}}} \quad \frac{m_d}{\Lambda_{\text{QCD}}} \quad \frac{m_s}{\Lambda_{\text{QCD}}}$$

$$\alpha_e$$

Small number of input parameters responsible for all of strongly interacting matter

Dimensionless plus a scale

Finely-tuned - QCD Vs Electroweak

Ordinary matter is unnatural !

Hierarchies

Neutron-Induced Fission

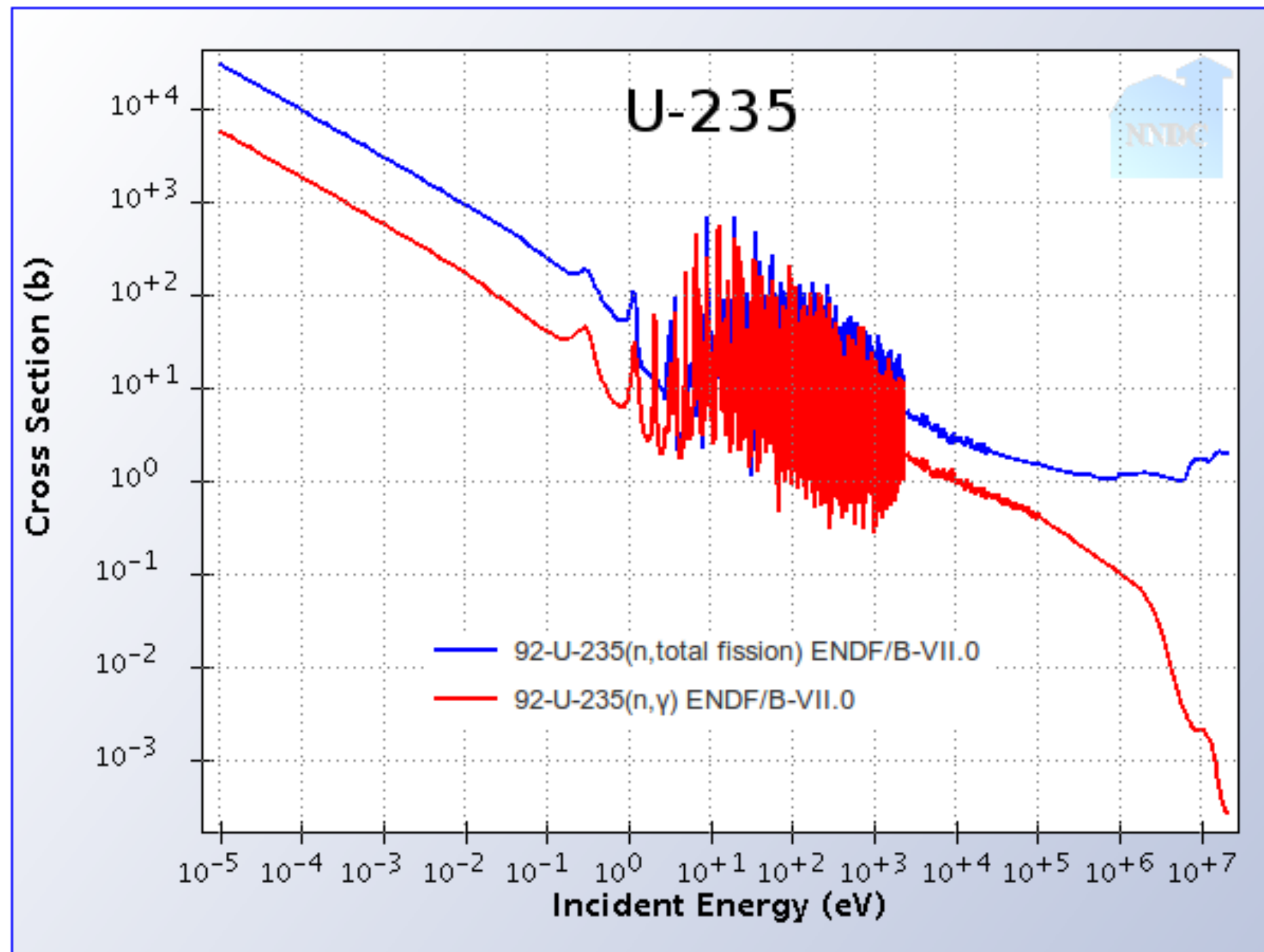

NN wavefunction at $E=0$

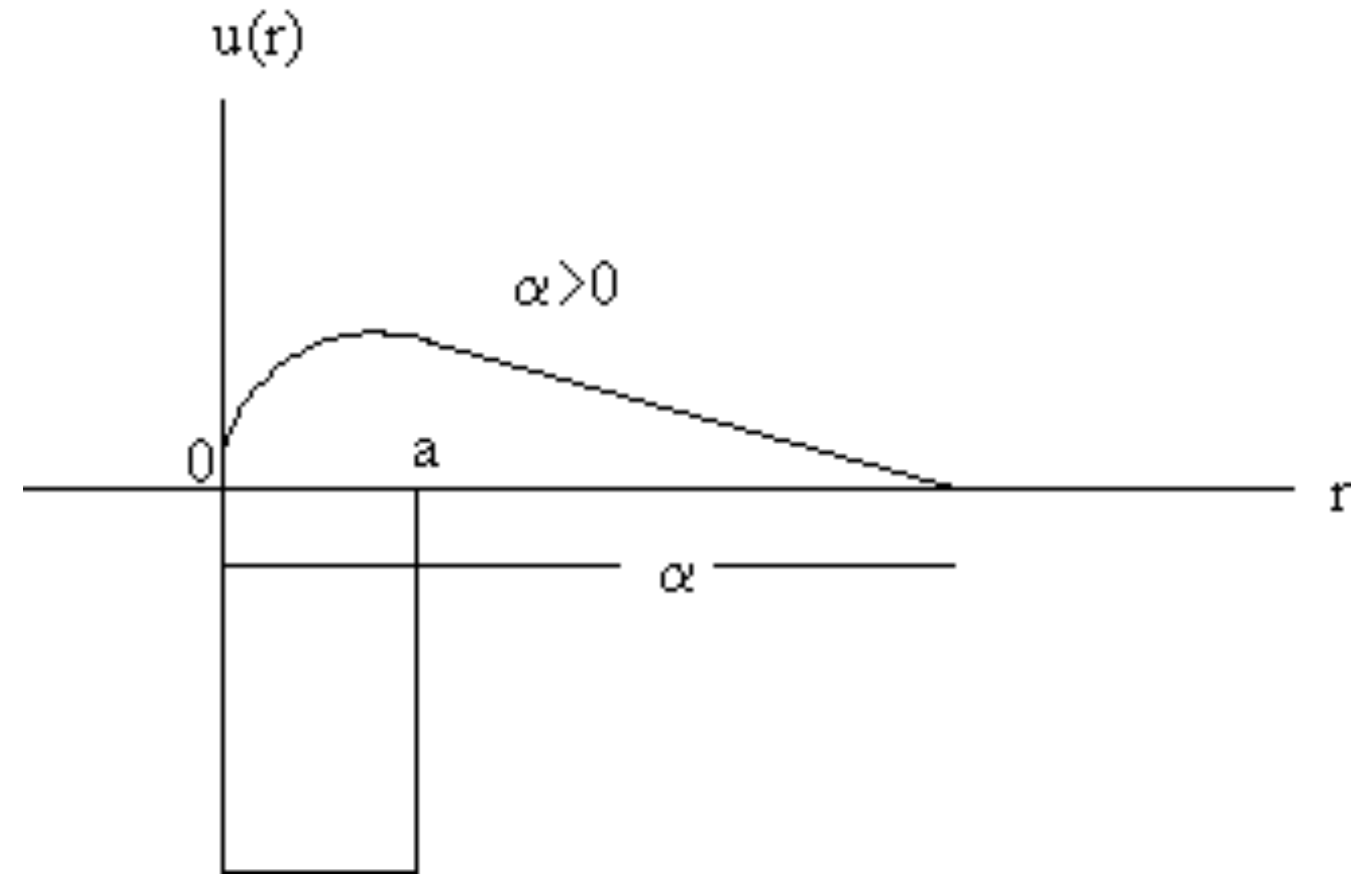

Mass $^{235}\text{U} \sim 220\,900$ MeV

Discovery Accelerated by Quantum Simulation and Technology

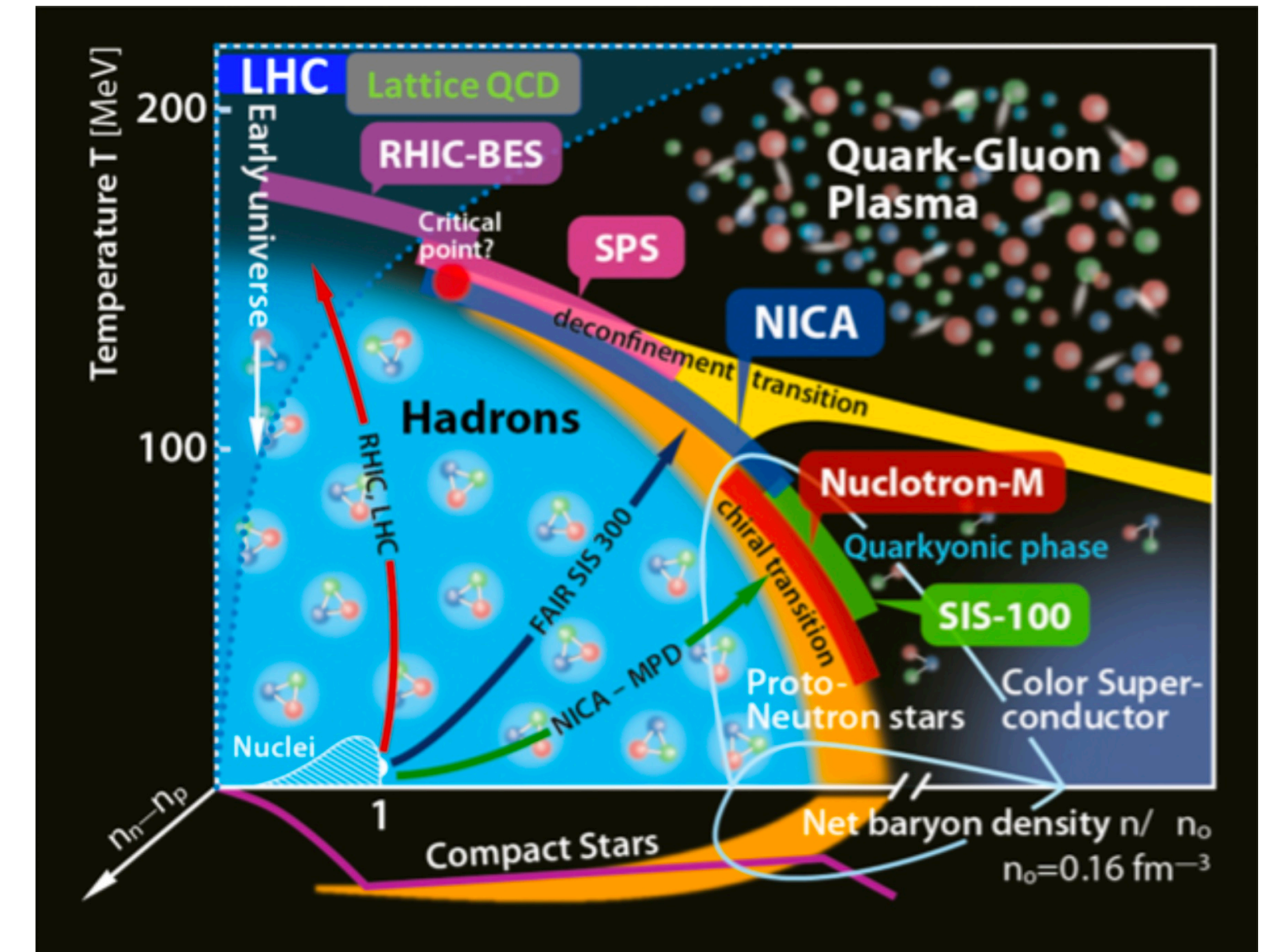
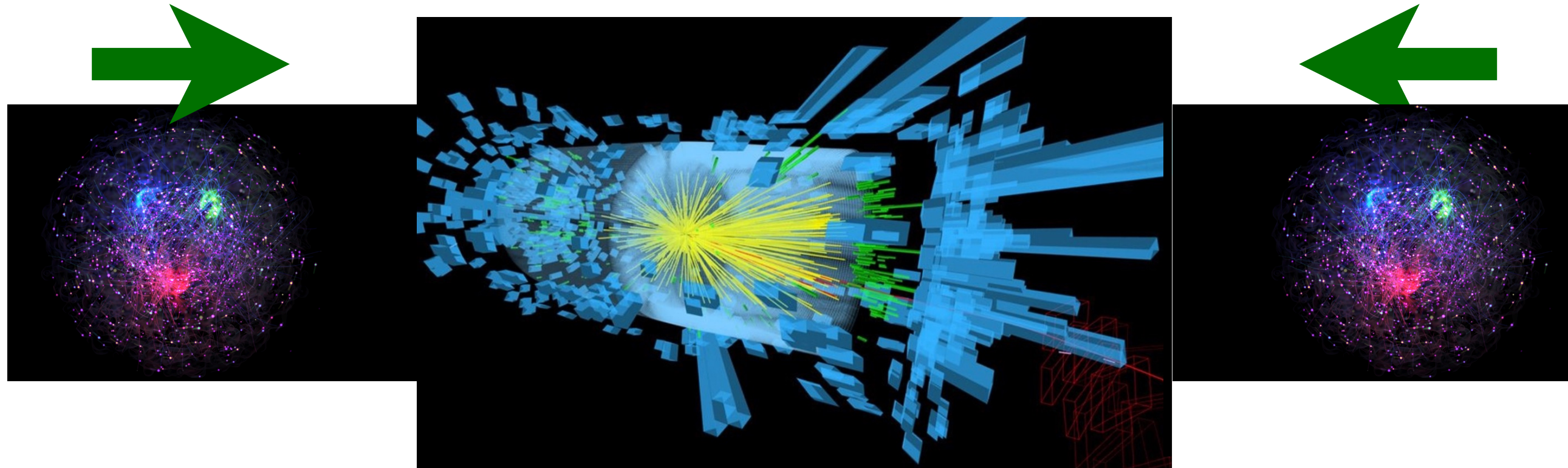

Why Quantum computers?

- Probe processes/mechanisms at yocto-sec time scales
- Predictions for experimentally inaccessible environments
- Nuclear reactions
- Non-equilibrium dynamics and thermalization
- Can ask “unphysical questions”

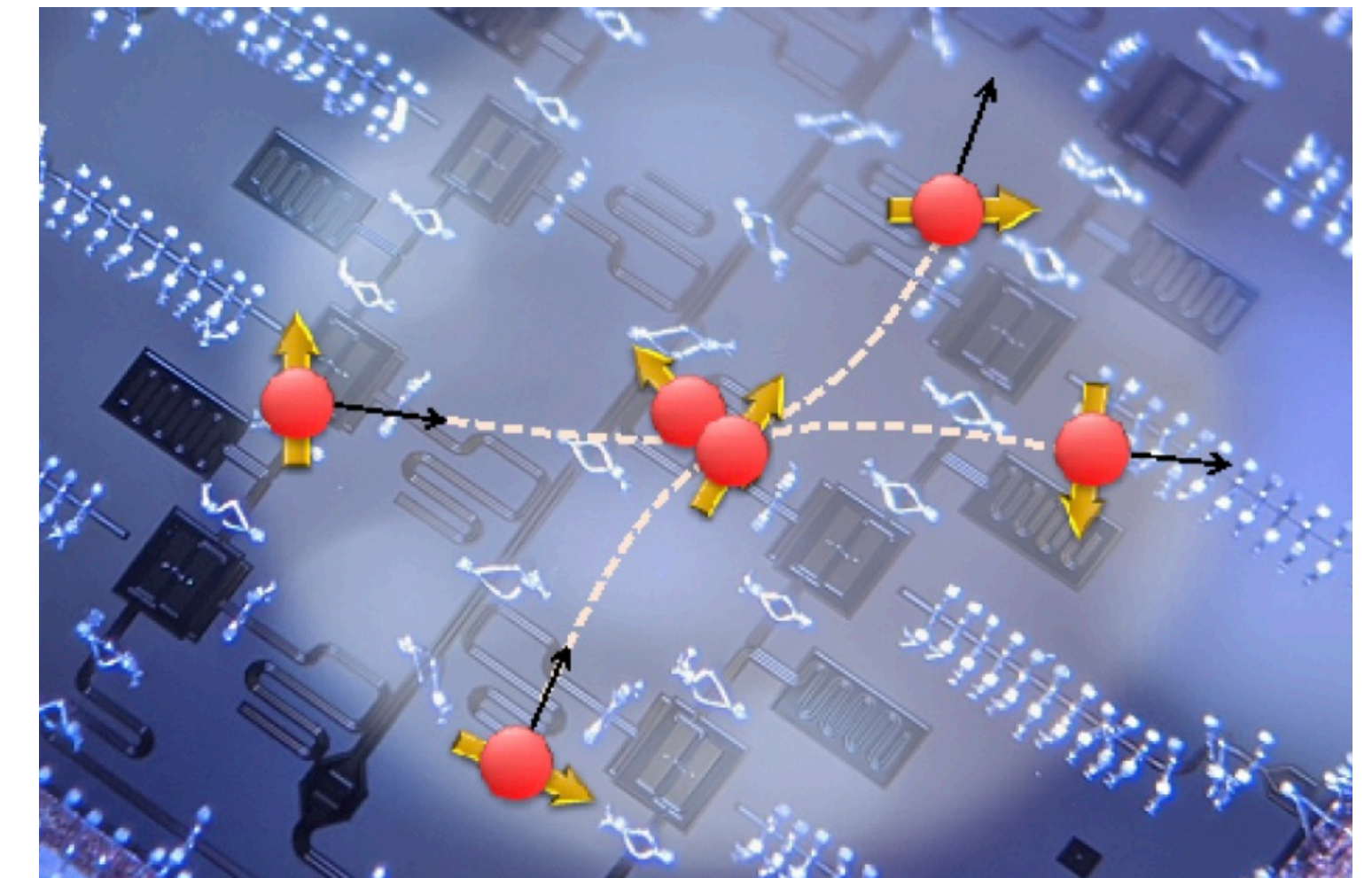

e.g., High-Energy Matter in Collision and Discovery

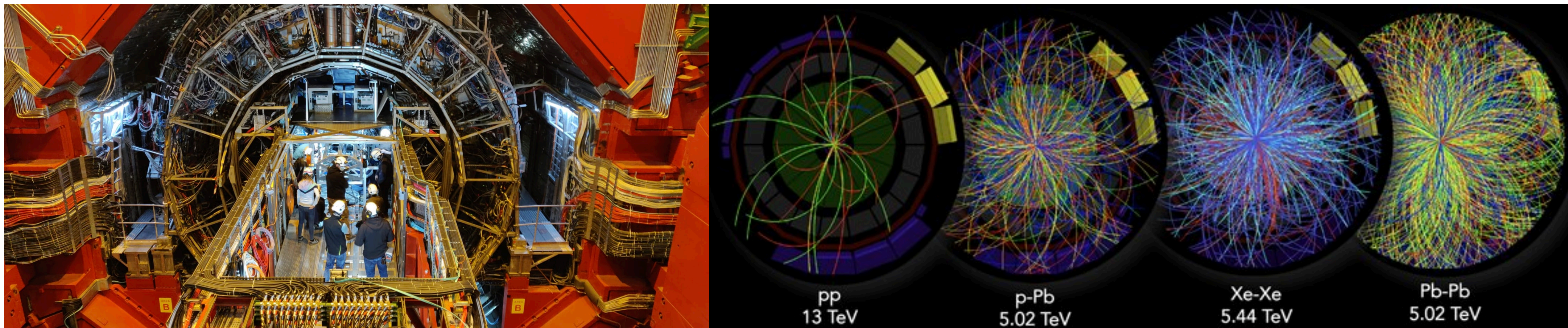

e.g., the ALICE Detector at CERN

Hadrons and Nuclei to QGP/Liquid to Hydrodynamics

e.g., Hot and Dense Non-Equilibrium Matter

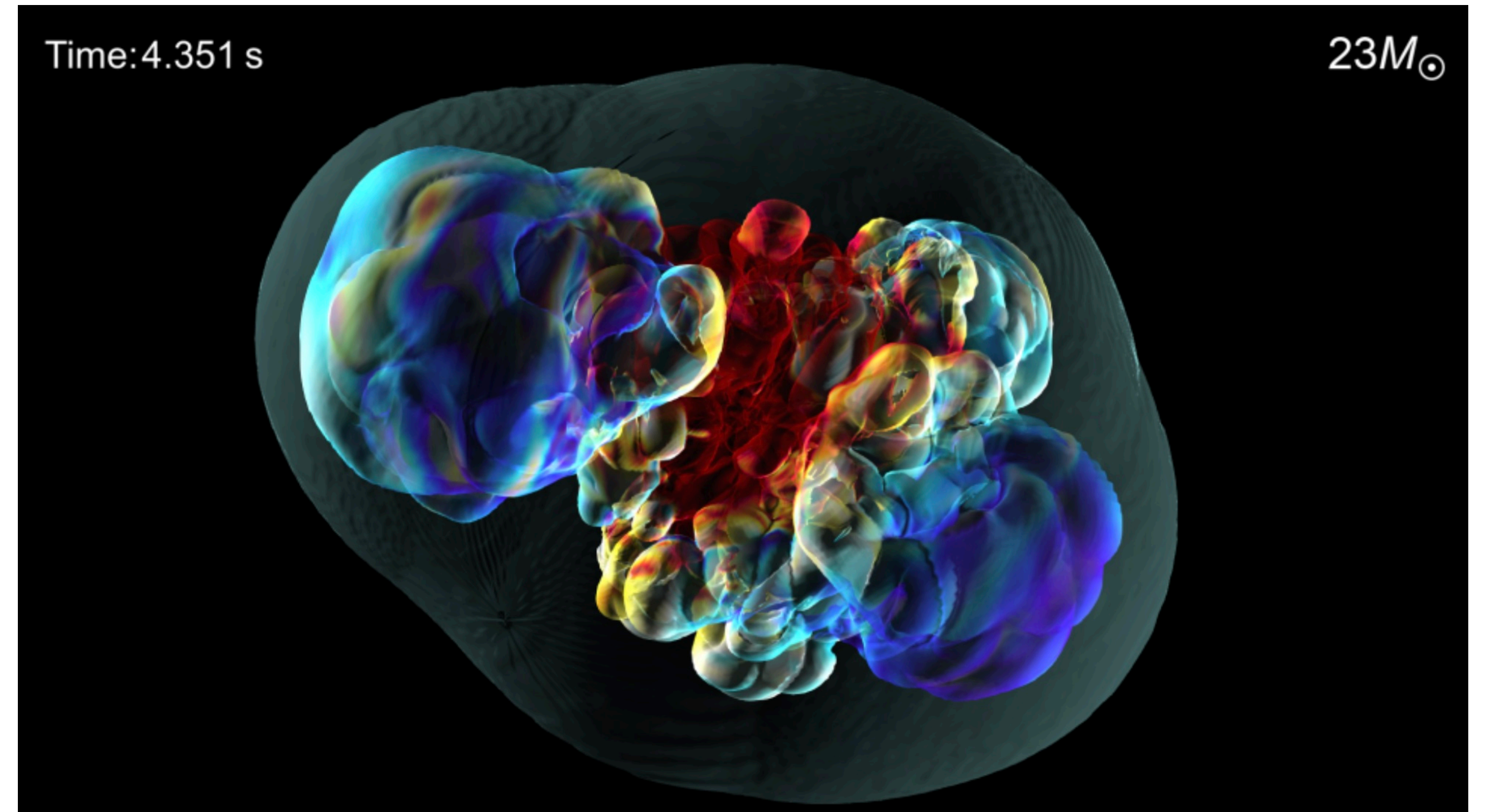
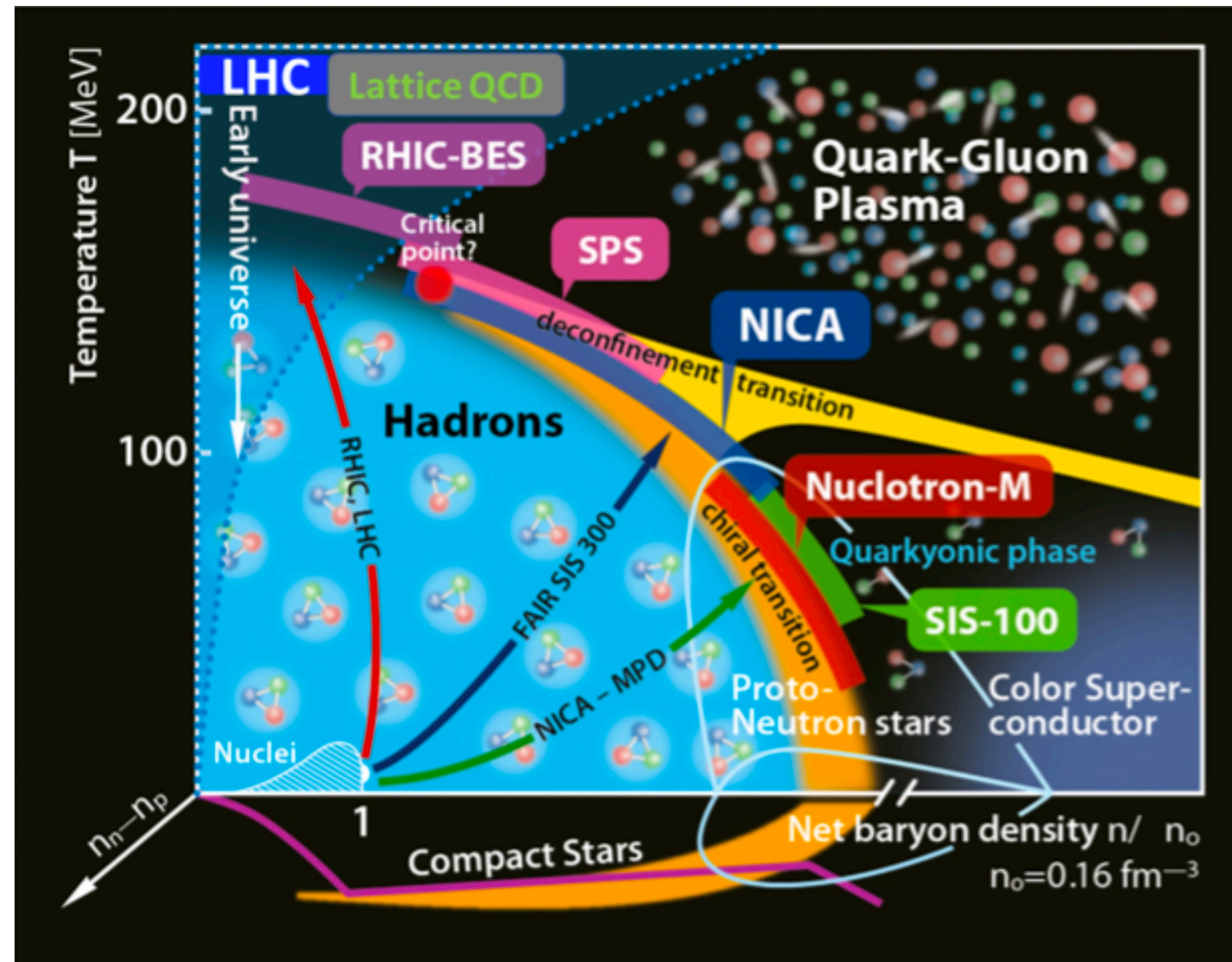

Possible early universe signals in proton collisions at the Large Hadron Collider

Raghunath Sahoo^{1,2,*} and Tapan Kumar Nayak^{2,3}

¹Department of Physics, Indian Institute of Technology Indore, Simrol, Indore 453552, India
²CERN, CH 1211, Geneva 23, Switzerland and

³School of Physical Sciences, National Institute of Science Education and Research, HBNI, Jatni-752050, India
 (Dated: January 4, 2022)

Next-Generation 3D Core-Collapse
 Supernova Simulations

PI Adam Burrows, Princeton University
 co-PI David Vartanyan, University of California Berkeley
 Matt Coleman, Princeton University
 Chris White, Princeton University

Moving Through New Exotic Matter - Transport

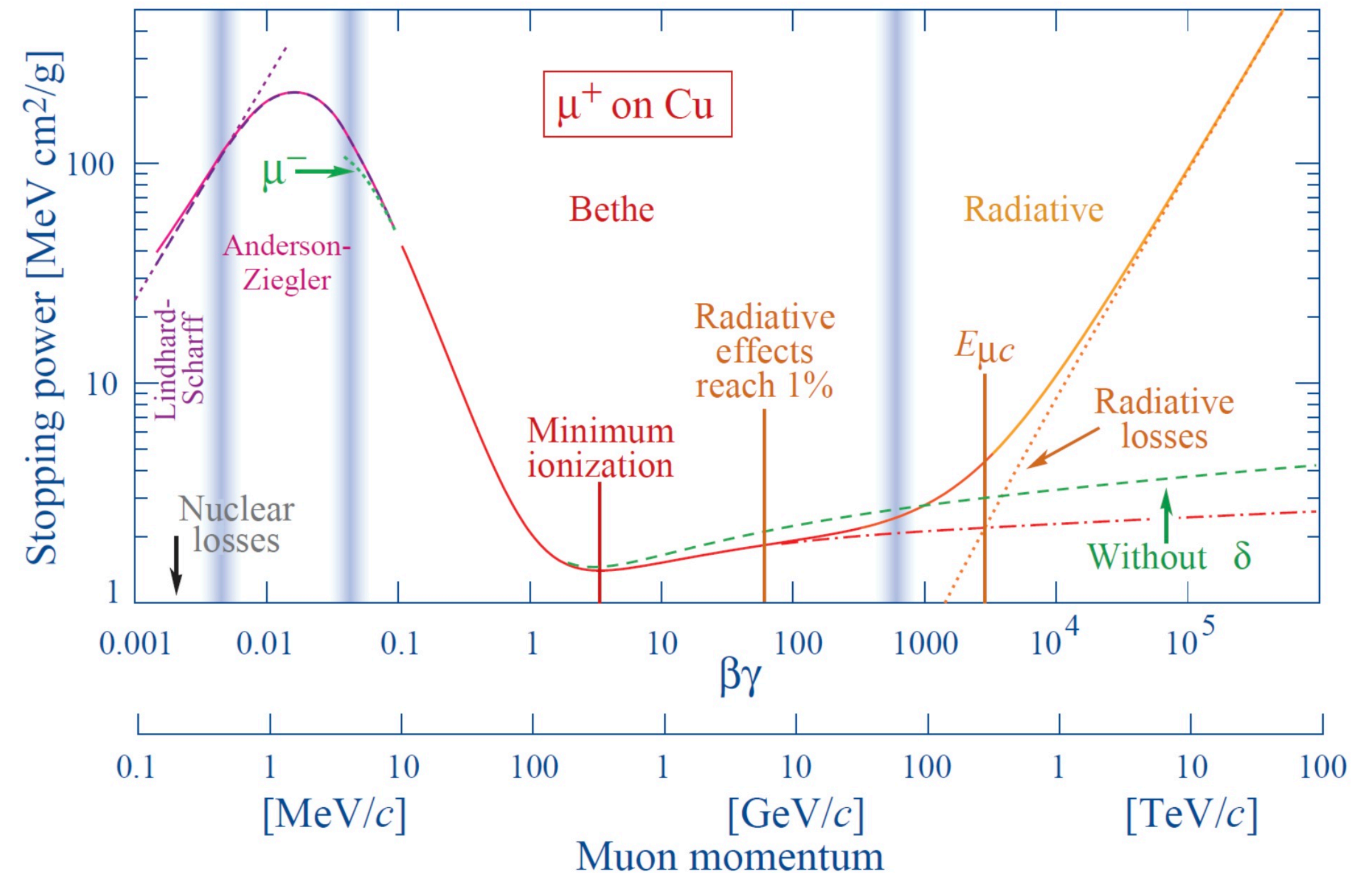
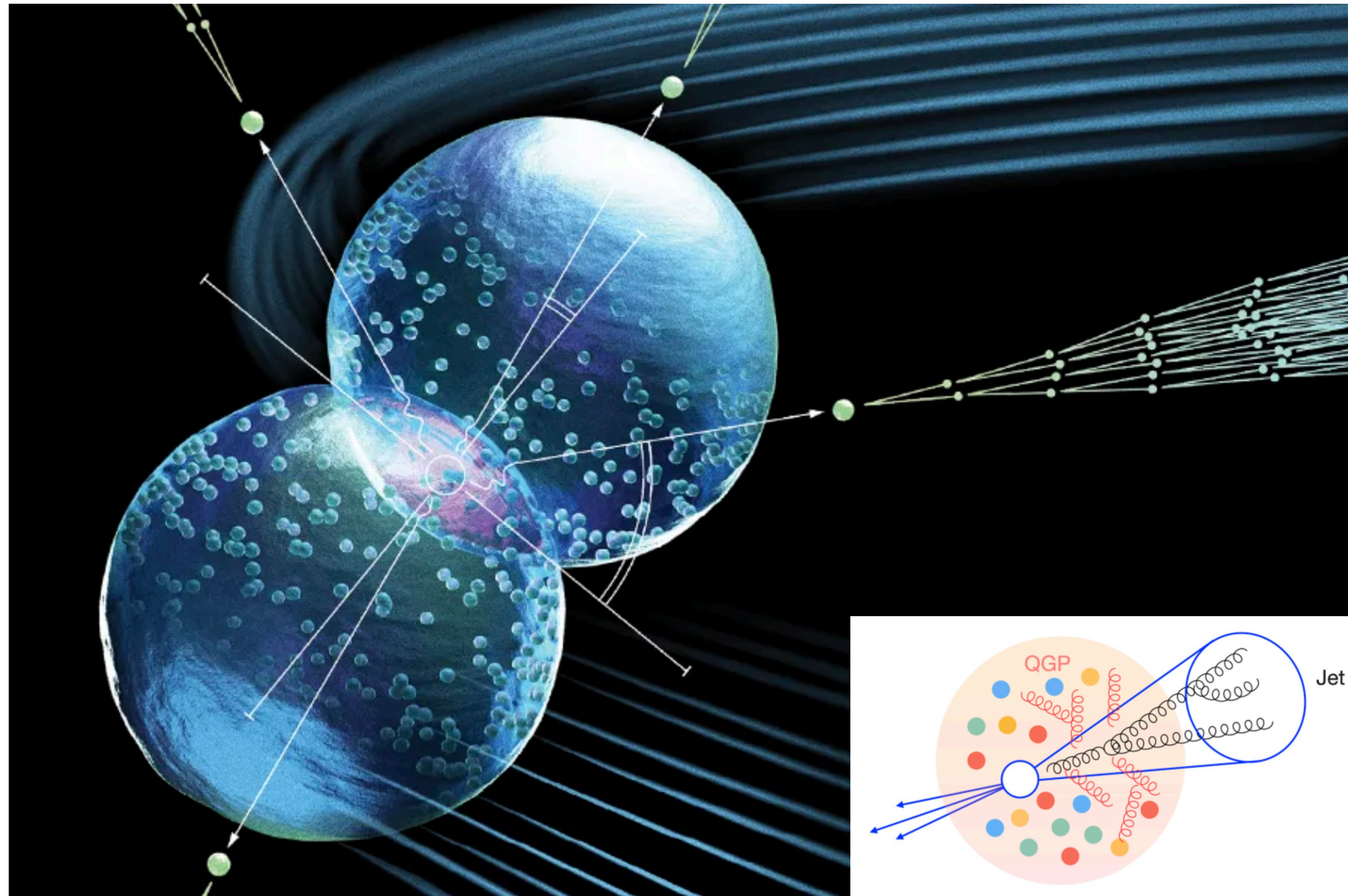

- Probe created matter via “signatures” entering detectors
 - e.g., production of heavy quarks and their composites
- Electromagnetic energy loss by particles is well measured/understood

Simulation Objectives for the Standard Model and Beyond

Gauge Theories and Descendent Effective Field Theories and Models

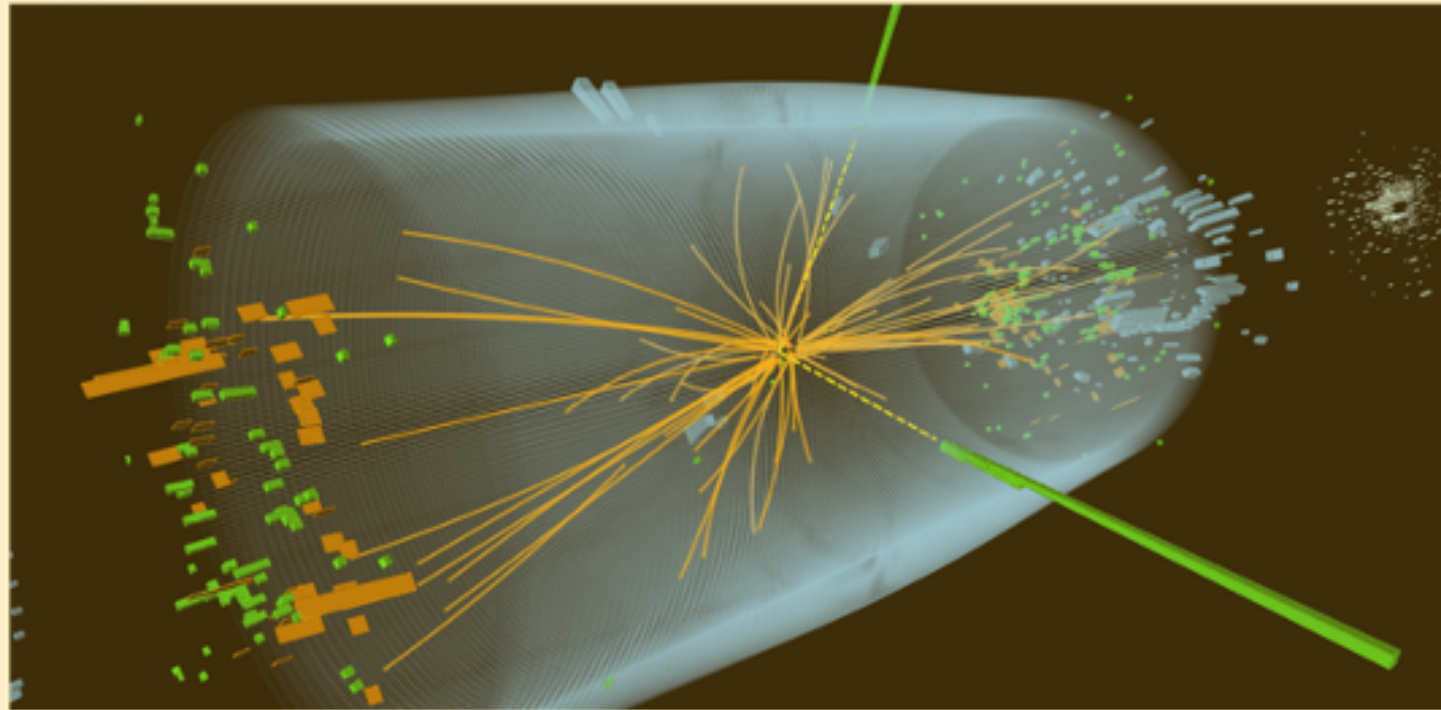

Real-time dynamics
particle production, fragmentation
vacuum and in medium

Low-energy reactions

Electroweak processes (e.g., ν -A)

Neutrino dynamics

Matter-antimatter asymmetry

BQP

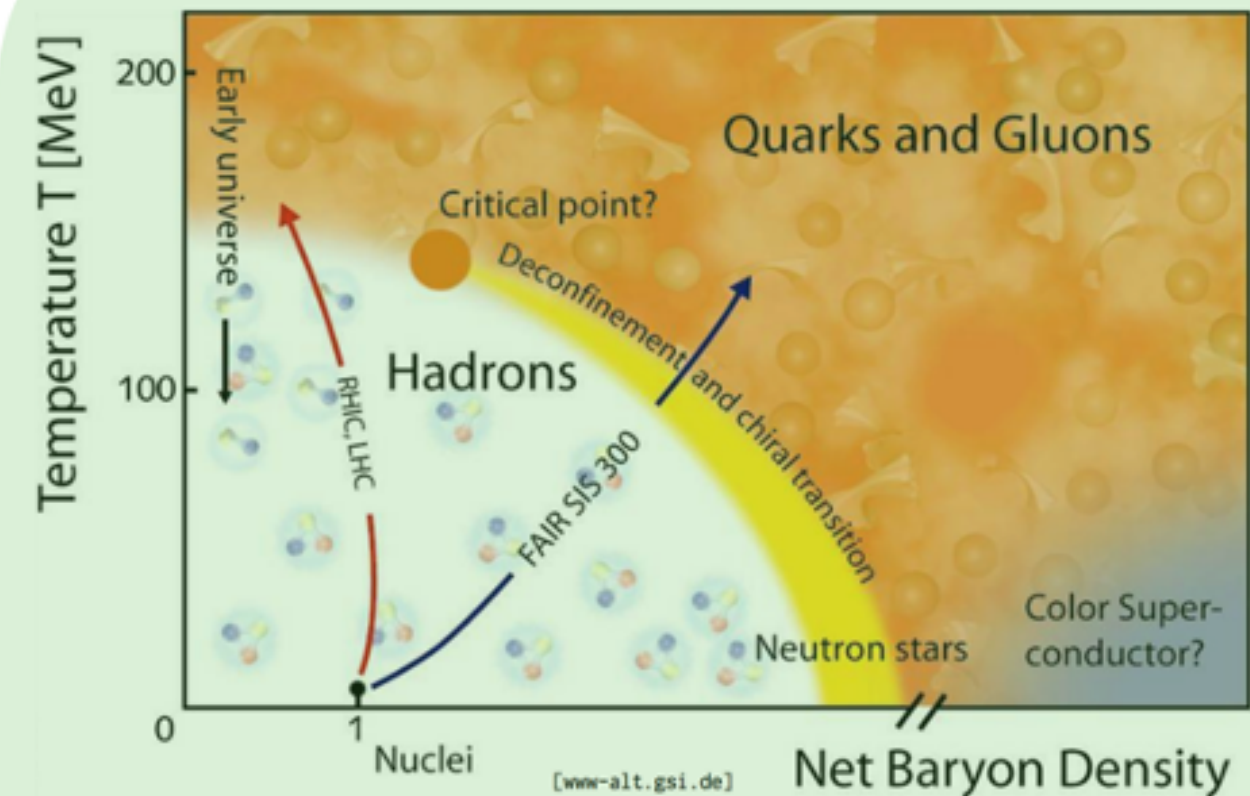

Equation of state of dense
hot matter and dynamics
viscosity, etc

Conquering some "sign problems"

The early universe

Supernova/Neutron stars

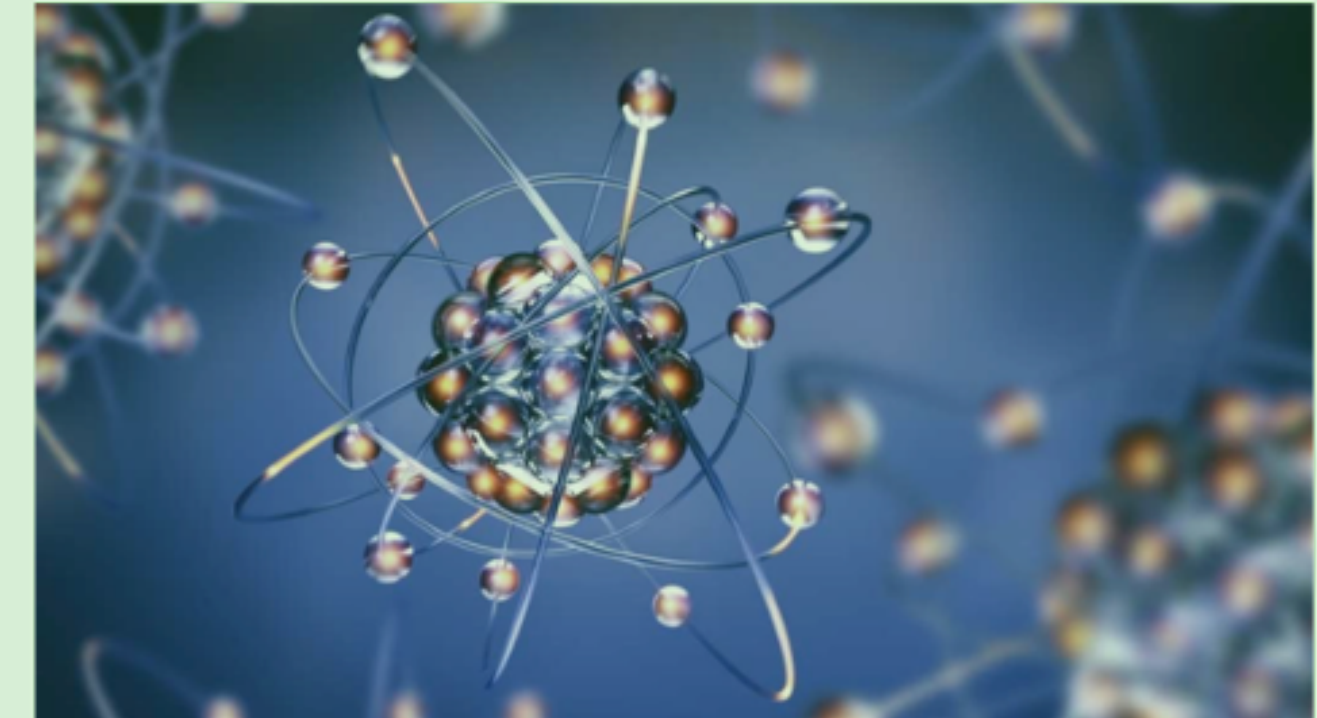

Precision structure and interactions
of nuclei

Many-body systems

Rare processes, double-beta decay

QMA

— symmetries_x

Quantum Systems for Quantum Systems

Quantum Mechanics “is the same” at all scales we have probed (so far)

Quantum Simulation uses quantum systems at one scale to simulate quantum systems at another scale!

(Feynman, Benioff, Manin and others, early 1980s)



New Zealand Silver Fern - The Koru

Flipping the Switch: 2016 - 2018

(2016) Exascale Resource Requirements For NP

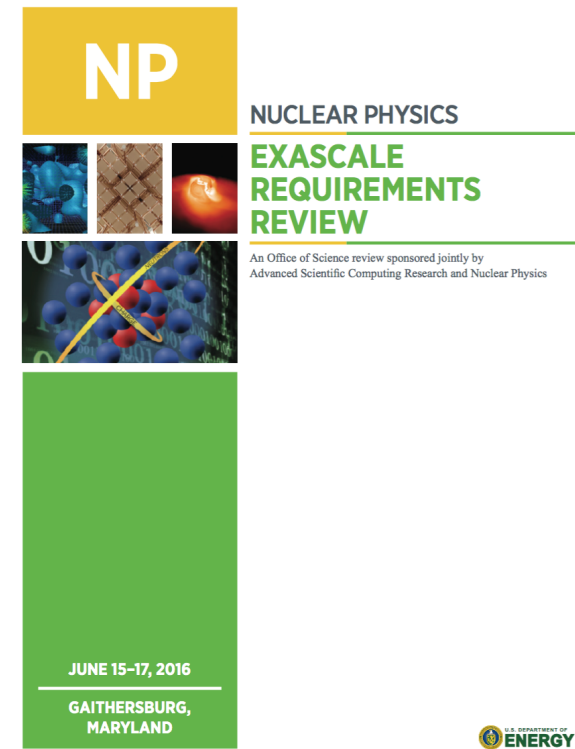

Finite-density and Real-time beyond exascale for NP

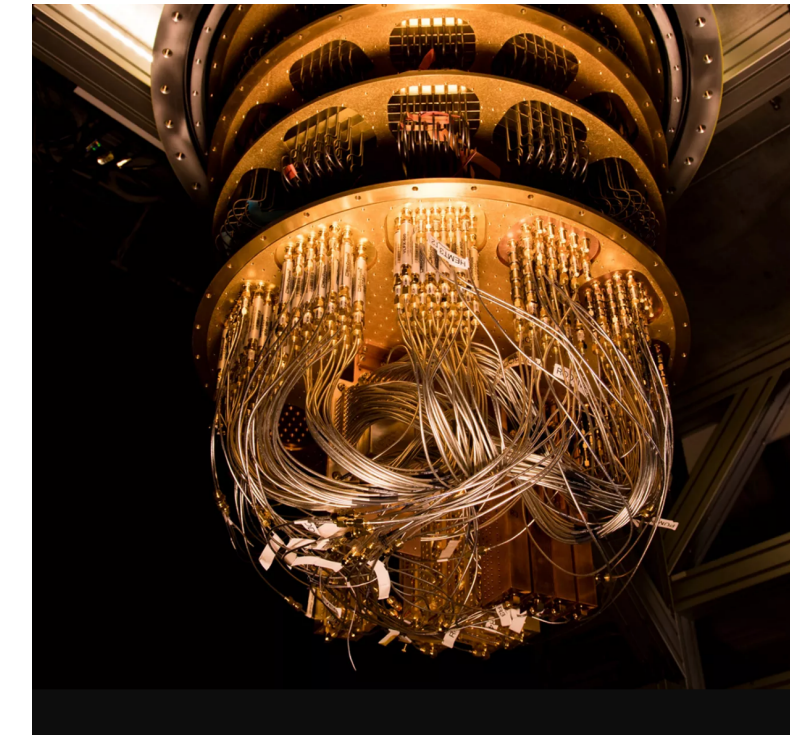

IBM Cloud-accessible quantum computers

2016 - Innsbruck
1+1D QED e+e-e+e-

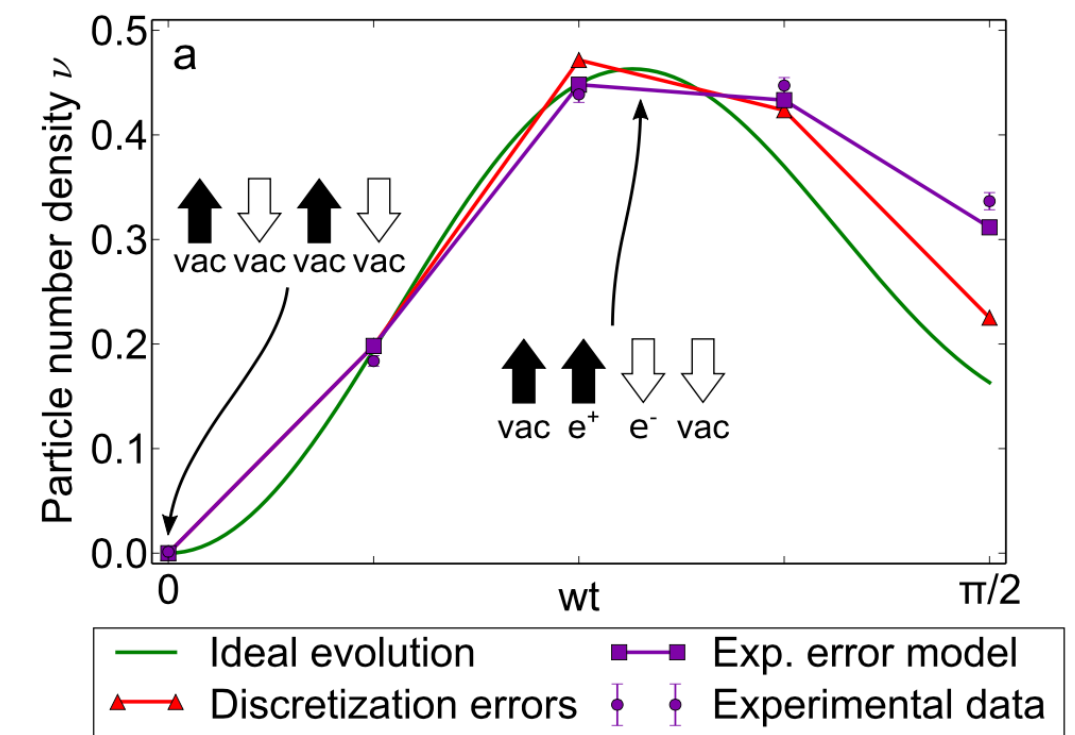
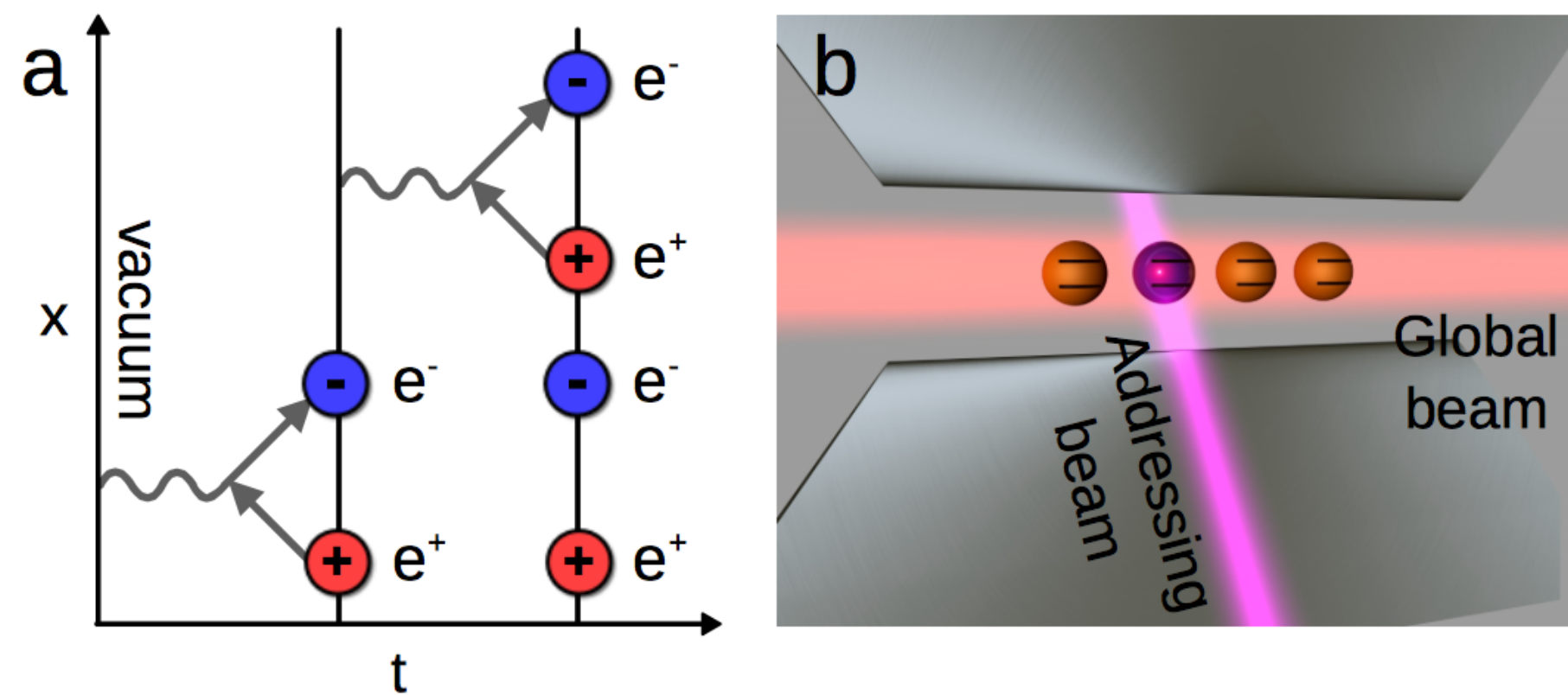

2018 - ORNL
The Deuteron

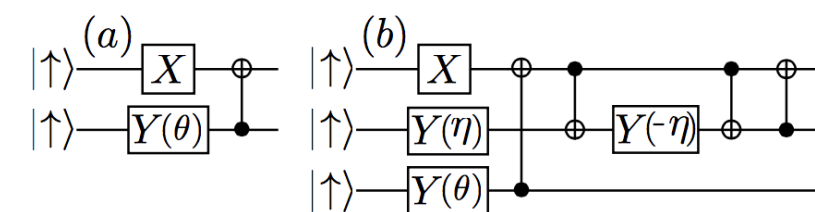
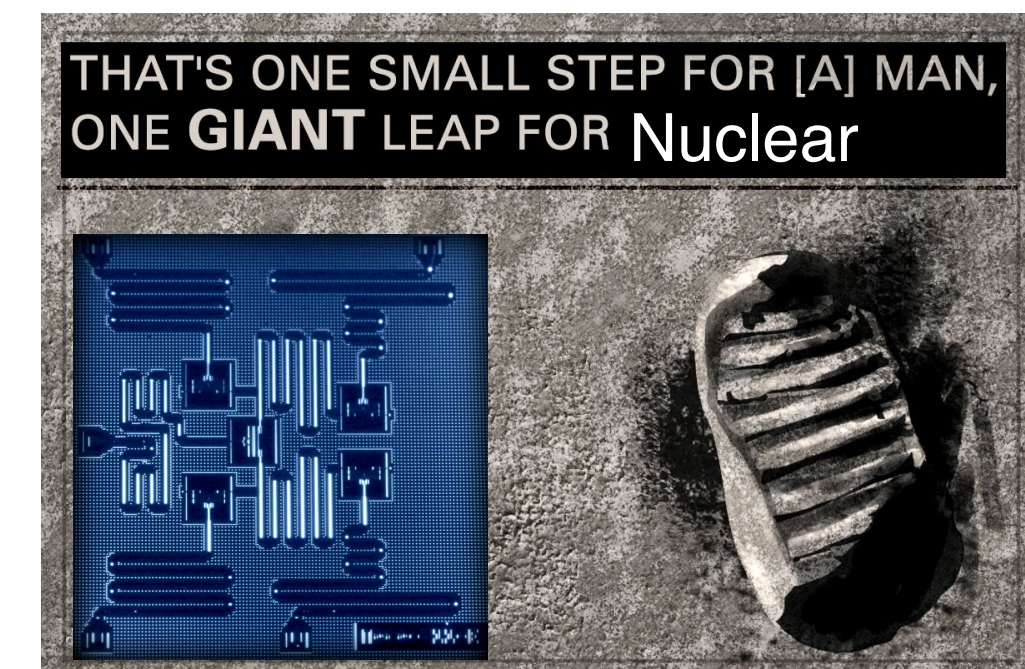
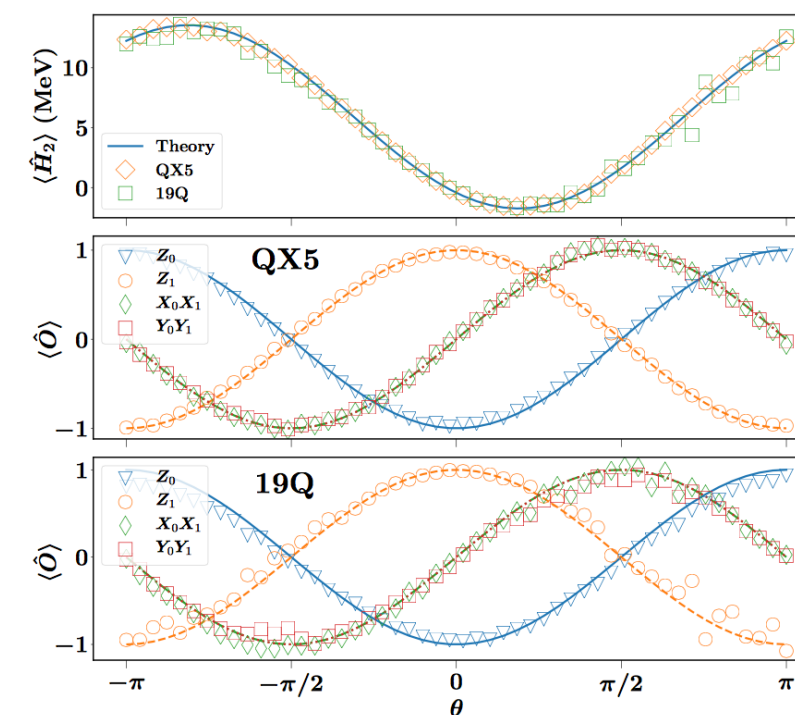

FIG. 1. Low-depth circuits that generate unitary rotations in Eq. (7) (panel a) and Eq. (8) (panel b). Also shown are the single-qubit gates of the Pauli X matrix, the rotation Y(θ) with angle θ around the Y axis, and the two-qubit CNOT gates.

of a Hamiltonian is to use UCC ansatz in tandem with the VQE algorithm [12, 15, 21]. We adopt this strategy for the Hamiltonians described by Eqs. (4) and (5). We define unitary operators entangling two and three orbitals,

$$U(\theta) \equiv e^{\theta(a_0^\dagger a_1 - a_1^\dagger a_0)} = e^{i\frac{\theta}{2}(X_0 Y_1 - X_1 Y_0)}, \quad (7)$$



Example Road Maps for Quantum Processors

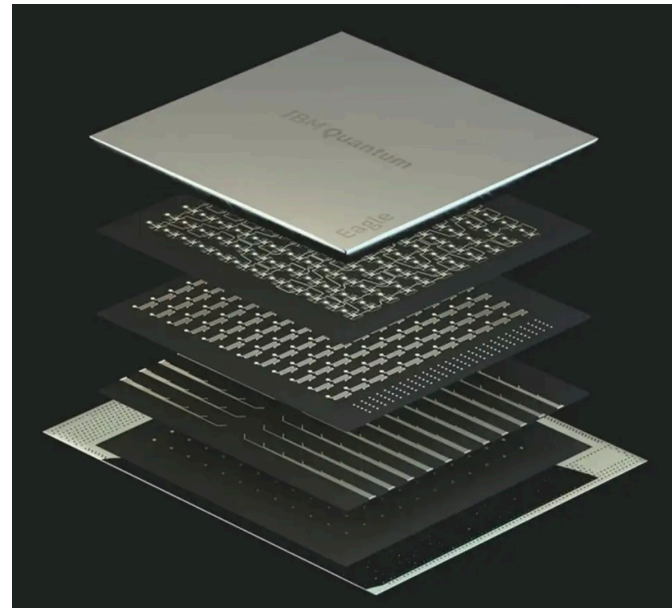

Superconducting

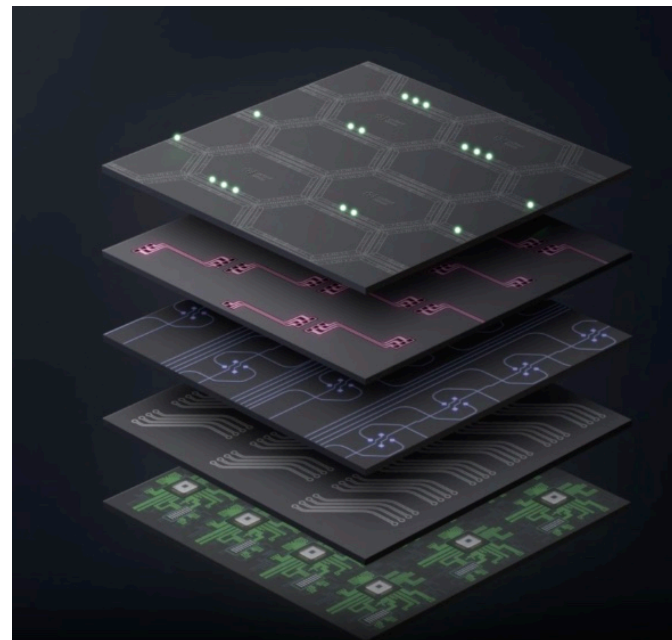
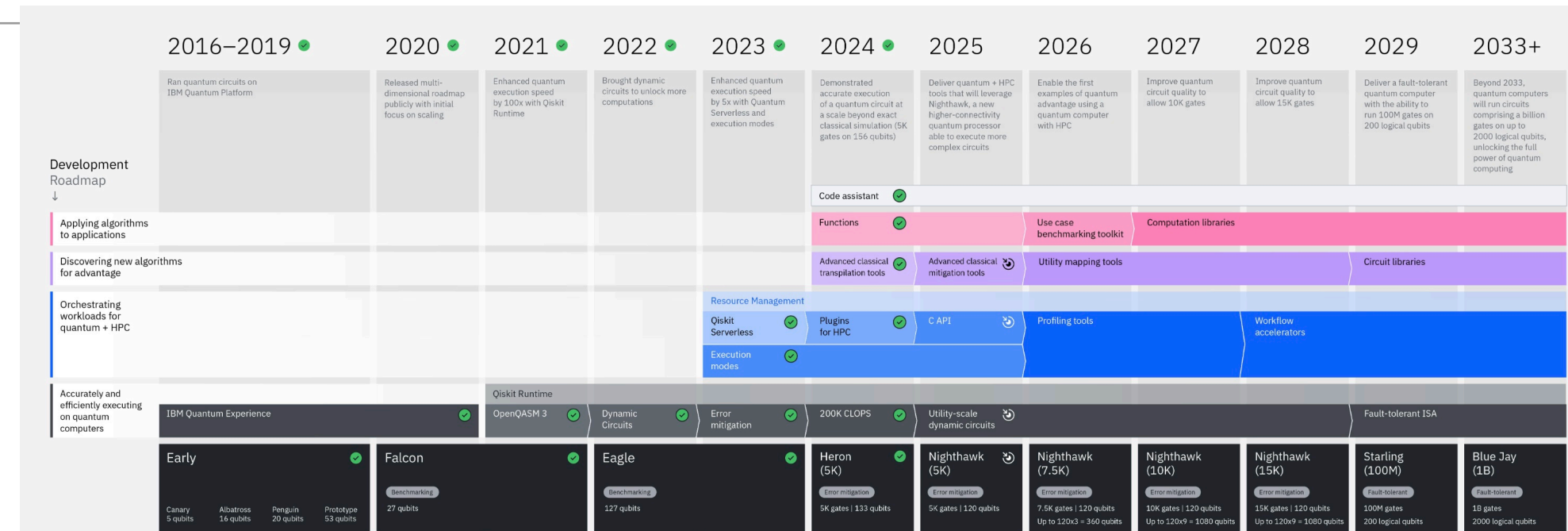

Trapped Ion

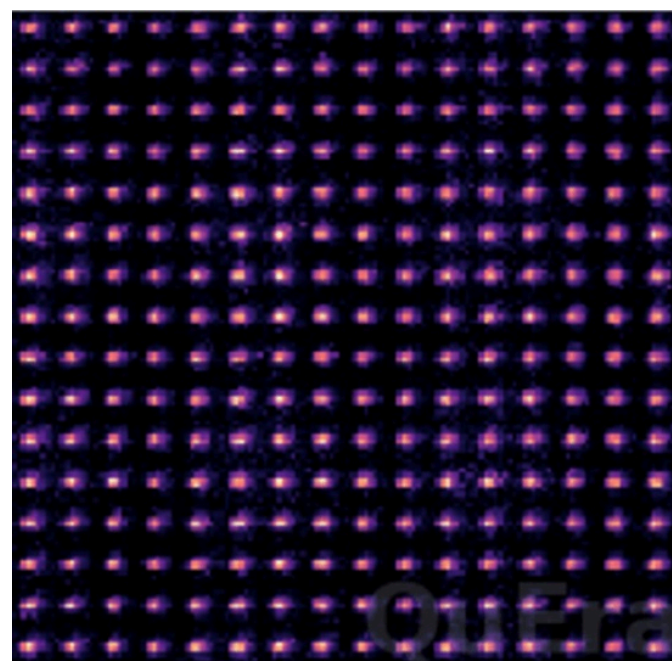
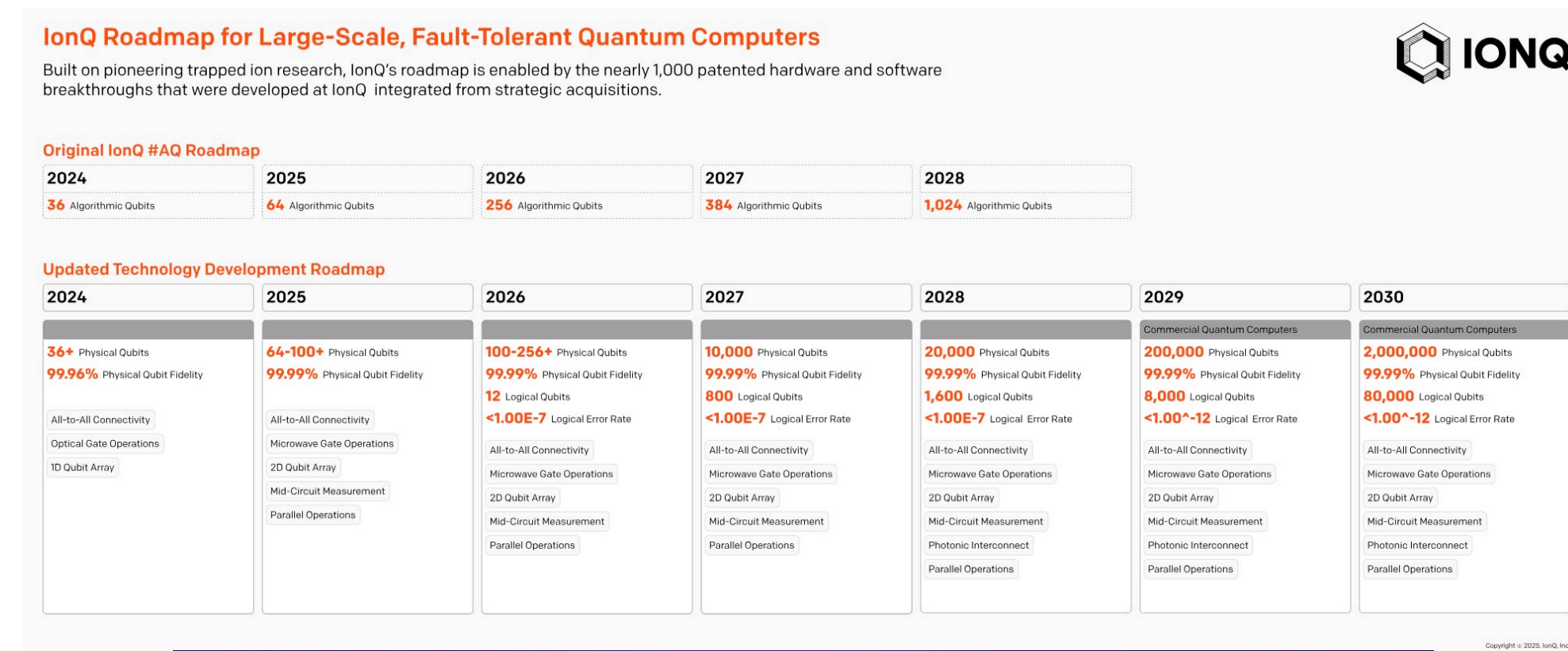

Neutral Atom

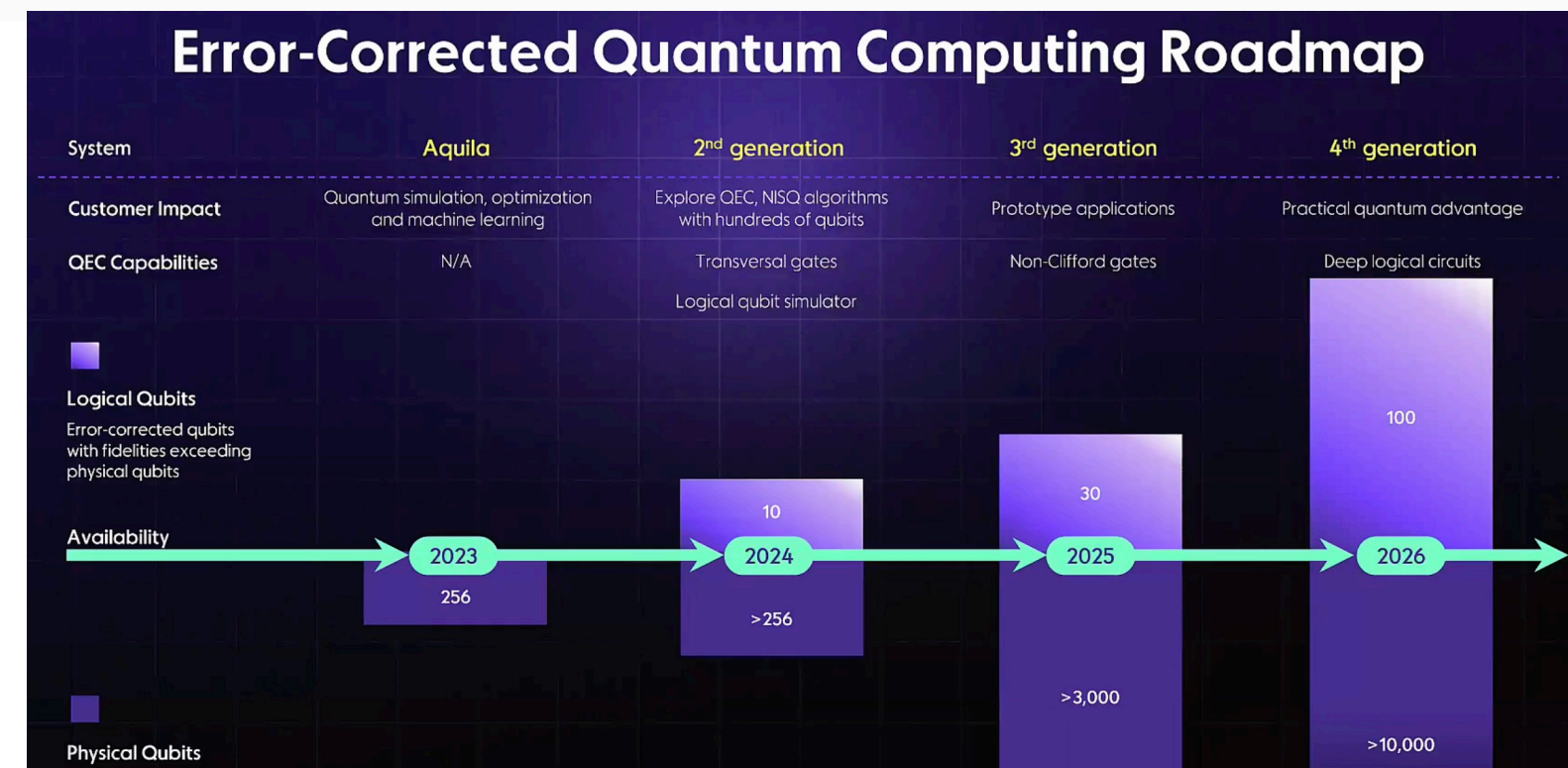

IBM Quantum Summit - NYC December 2023



Jay Gambetta
IBM Fellow & VP
IBM Quantum

Utility-scale experiments

With quantum systems composed of 100+ qubits, researchers are beginning to explore algorithms and applications at scales beyond brute-force classical computation [using IBM Quantum systems](#).

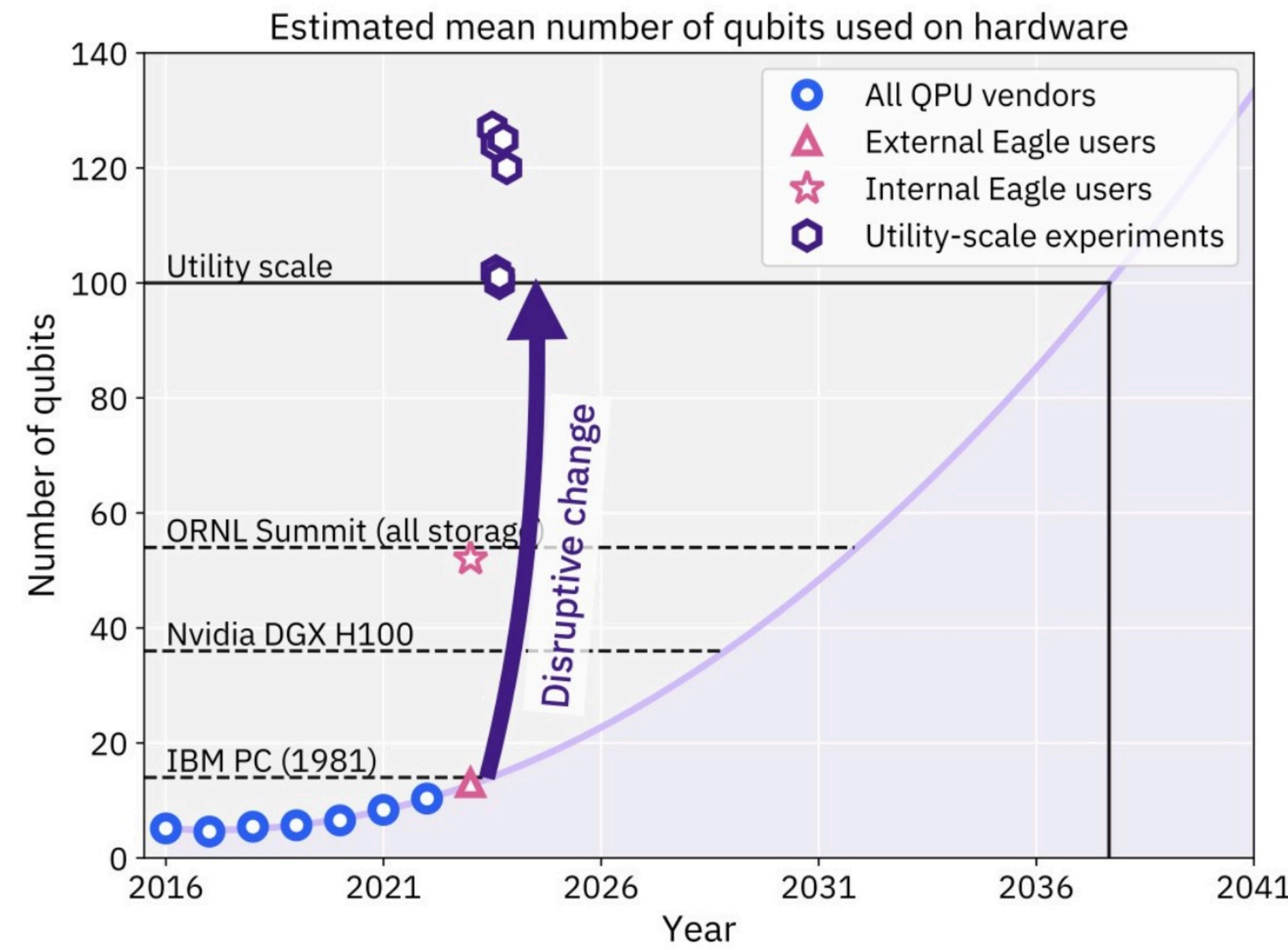

IBM Quantum

- Evidence for the utility of quantum computing before fault tolerance**
[127 qubits / 2880 CX gates](#) Nature, 618, 500 (2023)
- Simulating large-size quantum spin chains on cloud-based superconducting quantum computers**
[102 qubits / 3186 CX gates](#) arXiv:2207.09994
- Uncovering Local Integrability in Quantum Many-Body Dynamics**
[124 qubits / 2641 CX gates](#) arXiv:2307.07552
- Realizing the Nishimori transition across the error threshold for constant-depth quantum circuits**
[125 qubits / 429 gates + meas.](#) arXiv:2309.02863
- Scalable Circuits for Preparing Ground States on Digital Quantum Computers: The Schwinger Model Vacuum on 100 Qubits**
[100 qubits / 788 CX gates](#) arXiv:2308.04481
- Efficient Long-Range Entanglement using Dynamic Circuits**
[101 qubits / 504 gates + meas.](#) arXiv:2308.13065
- Quantum reservoir computing with repeated measurements on superconducting devices**
[120 qubits / 49470 gates + meas.](#) arXiv:2310.06706

Select Advances in Quantum Computing

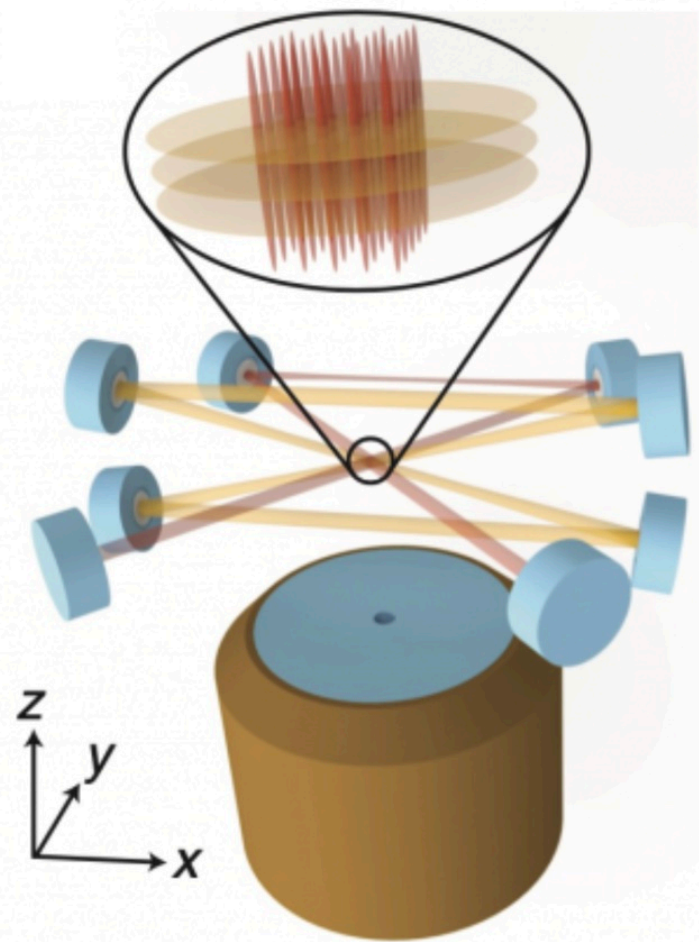

Cold-Atom arrays with Optical Tweezers

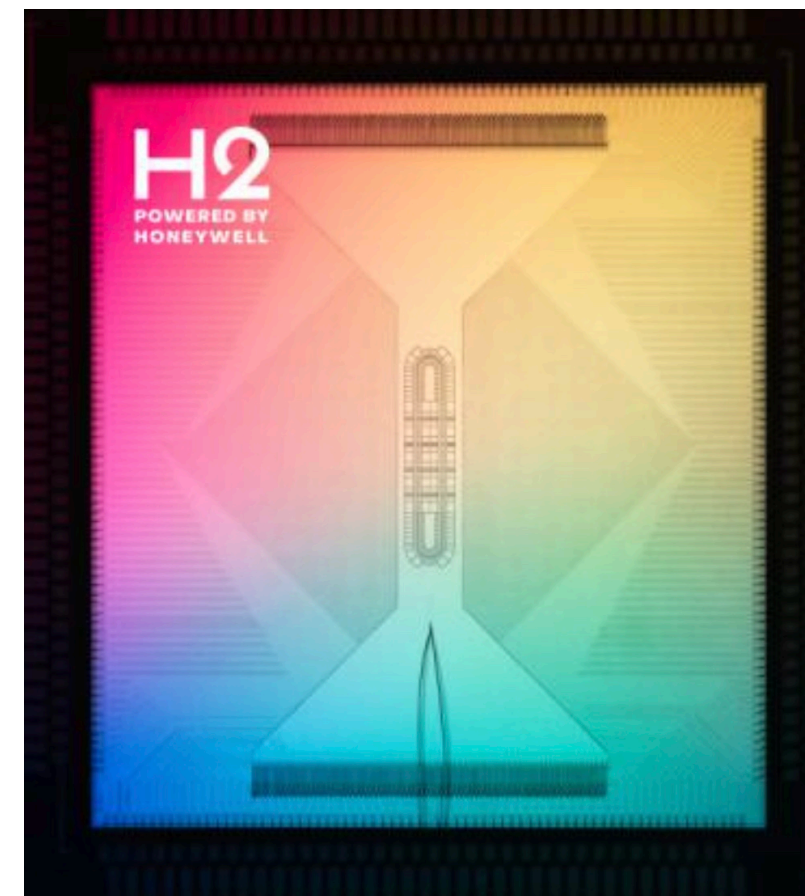

4 Logical Qubits
32-qubit H2-1 trapped ions
(Quantinuum-Microsoft)

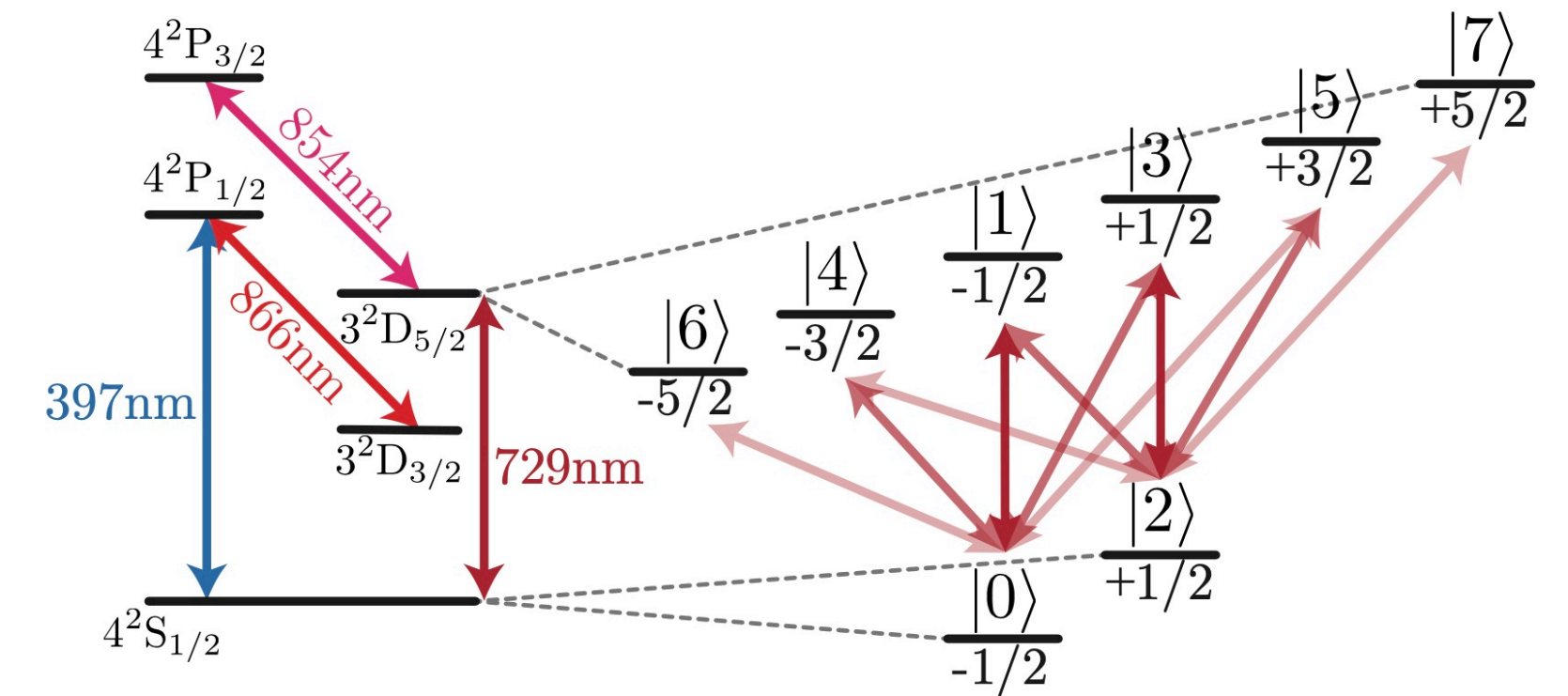
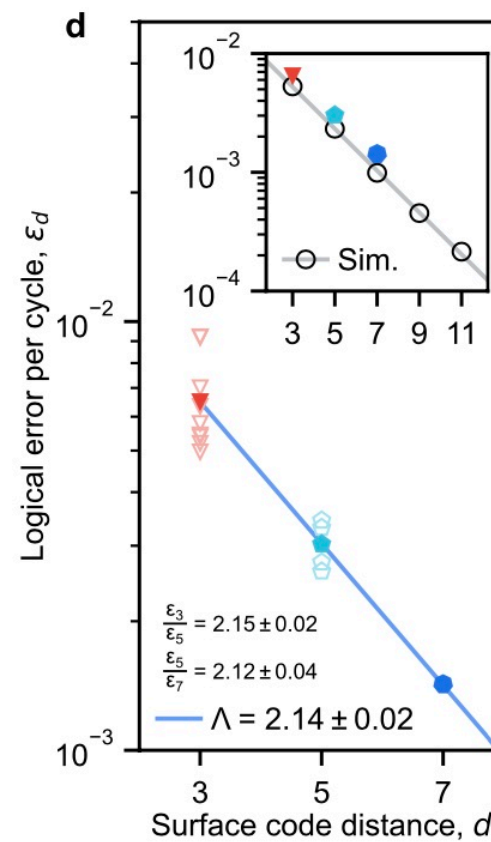
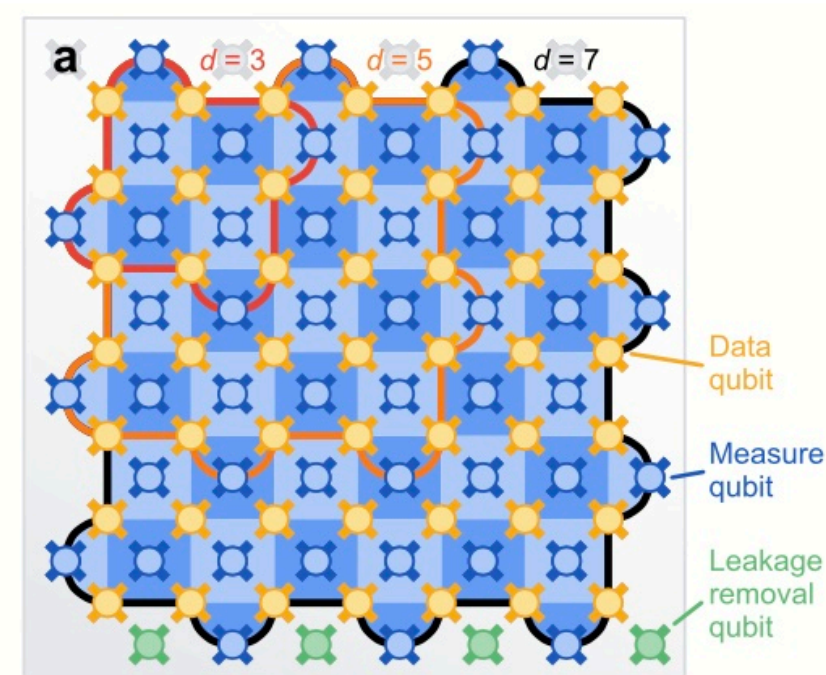
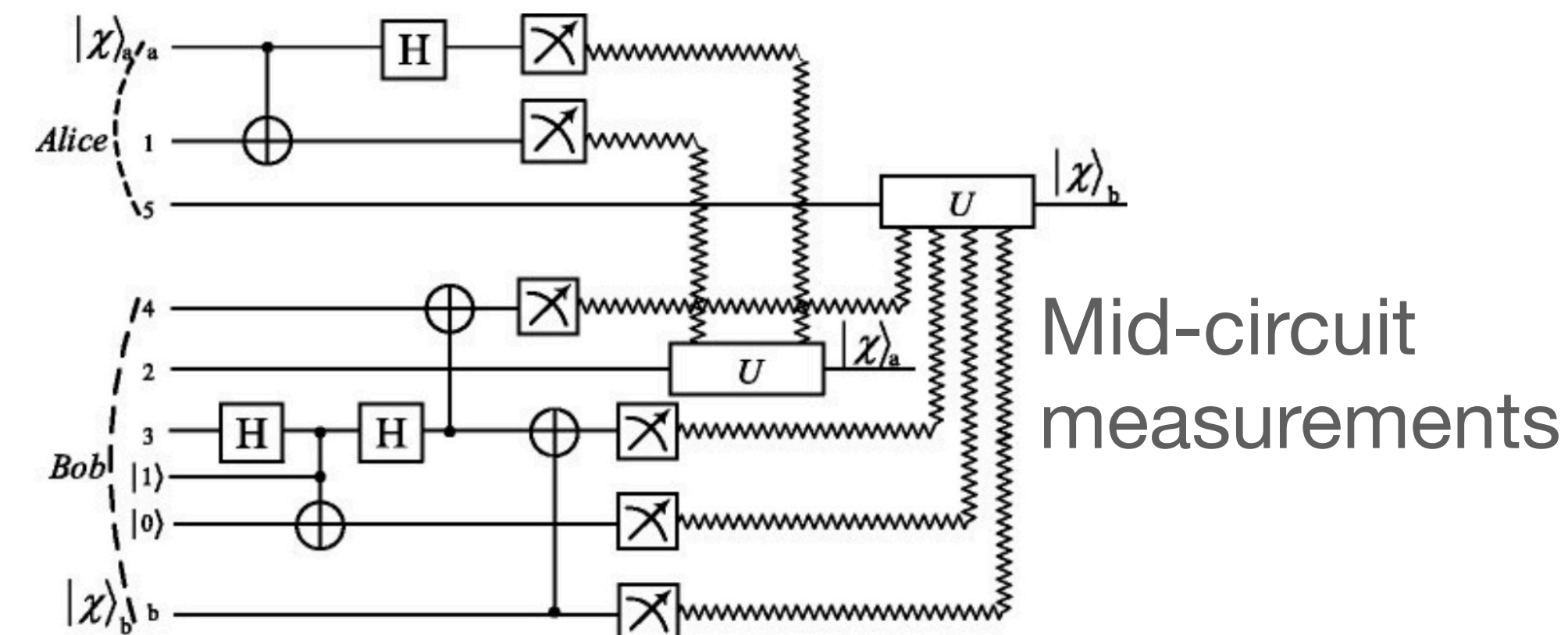

FIG. 1. Level scheme of the $^{40}\text{Ca}^+$ ion.

Qudits with trapped ions



Surface code
>100 superconducting qubits



From Classical to Error-Corrected Quantum Computing

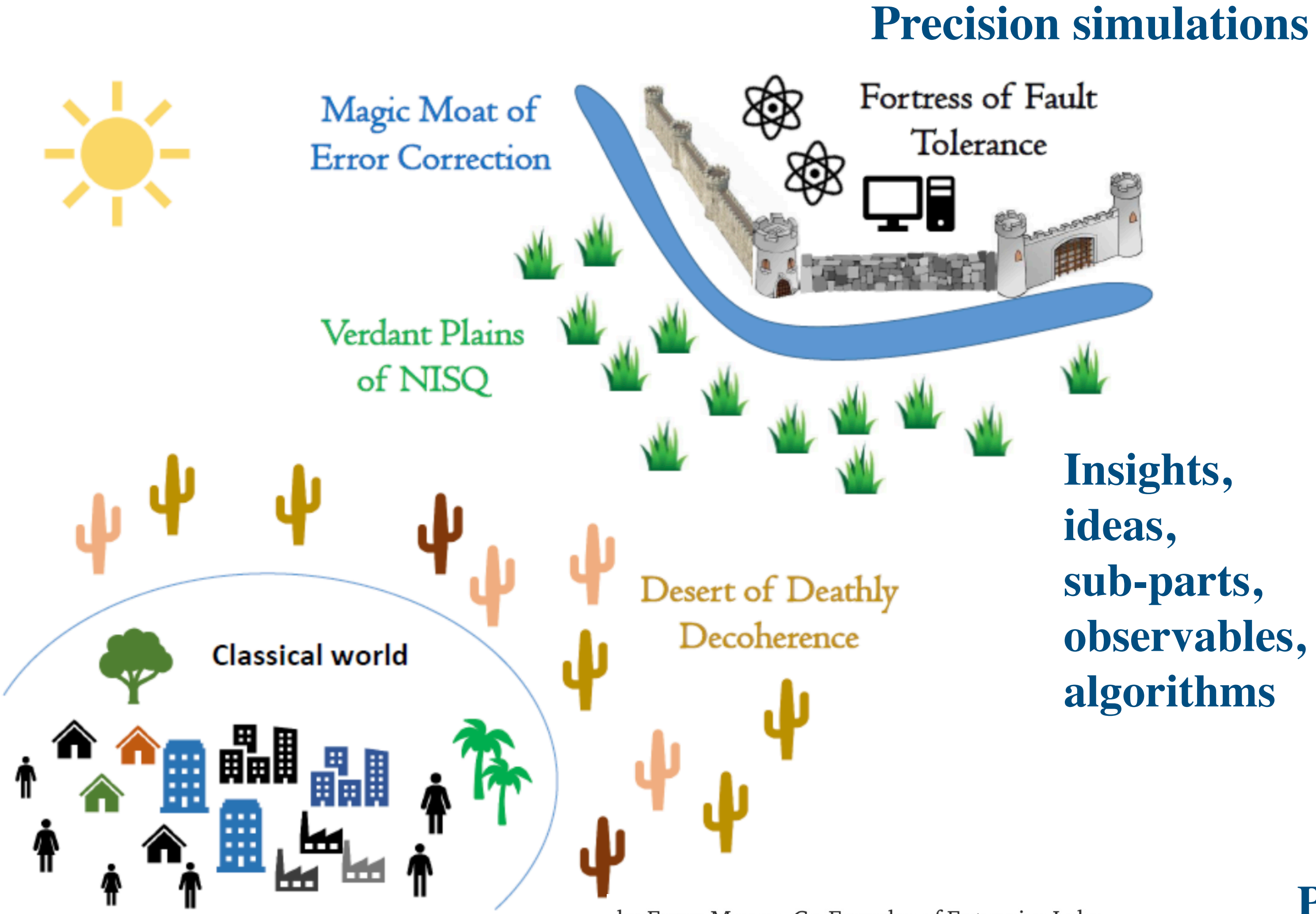

Precision simulations

Physics Output Optimization

by Ewan Munro, Co-Founder of Entropica Labs.
Landscape of quantum computing from an error correction perspective. Inspired by a figure by Daniel Gottesman.

Encoding Physical Systems

Different Architectures and Different Formulations
Physics-Aware Quantum Simulations

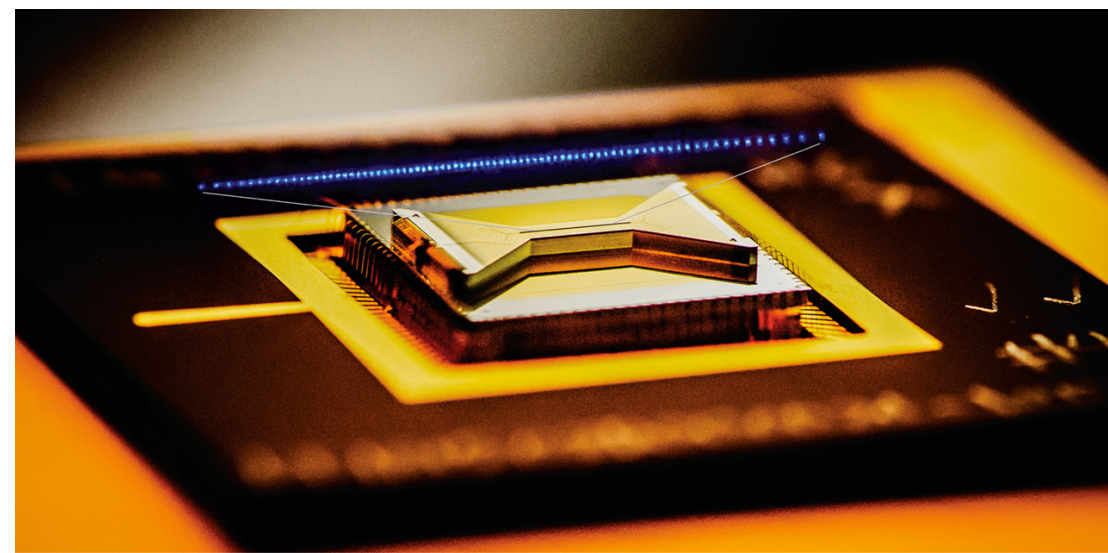

Trapped Ions

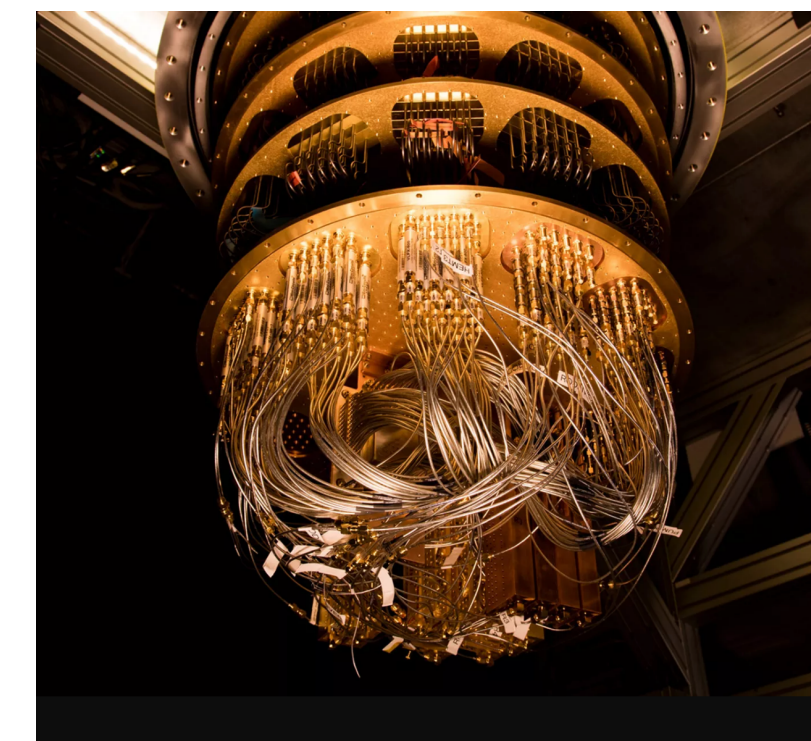
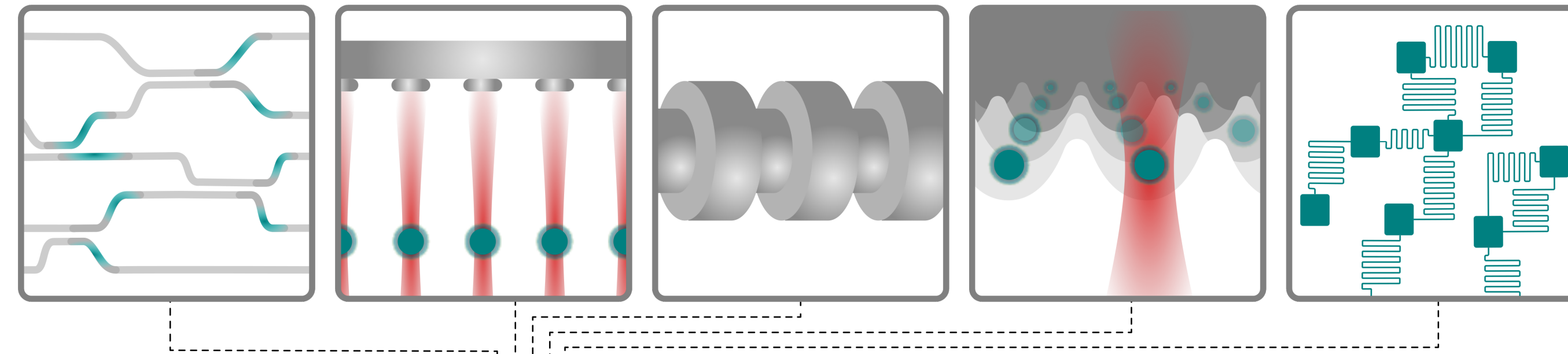

Superconducting qubit

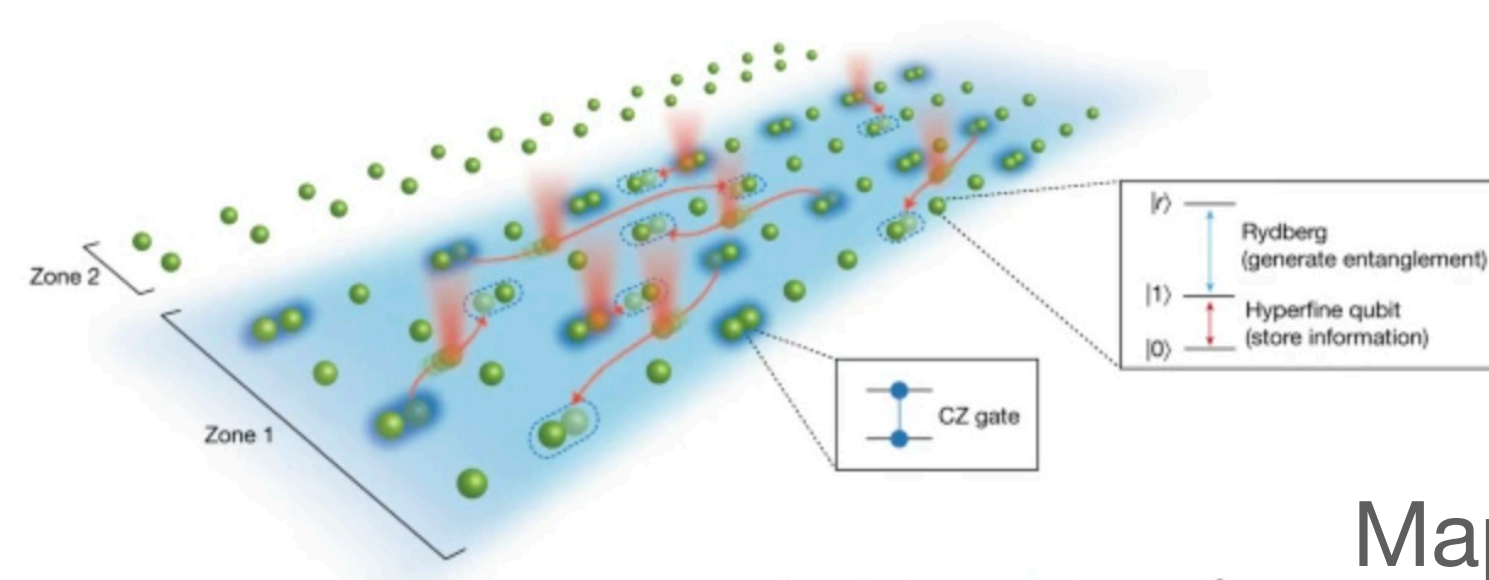

Neutral Atoms

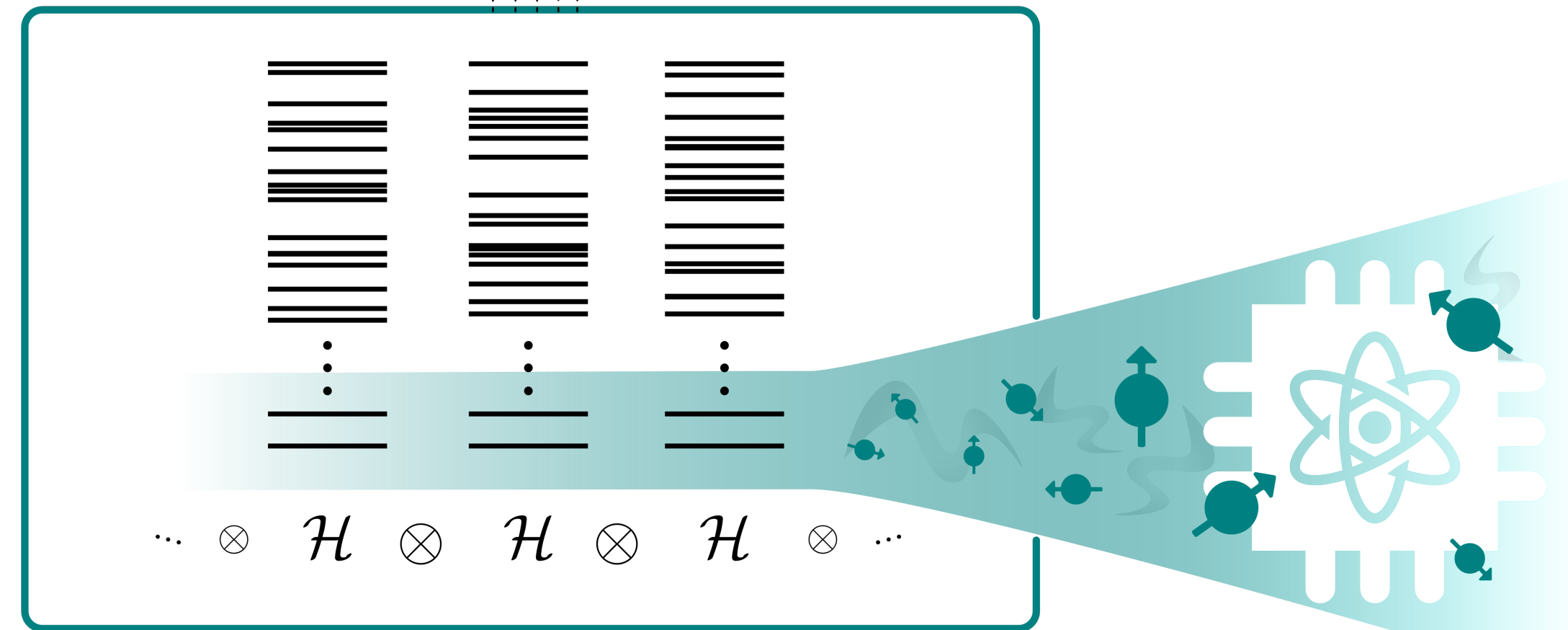

Map fundamental fields

Optimize for target observables - Physics Aware

Human-intensive co-design exploration

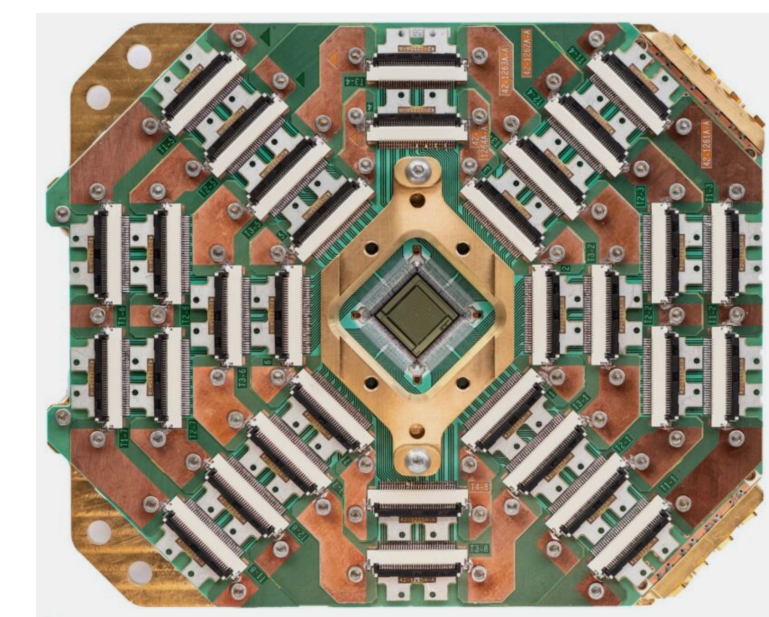

Annealer

Part-2

Quantum Complexity

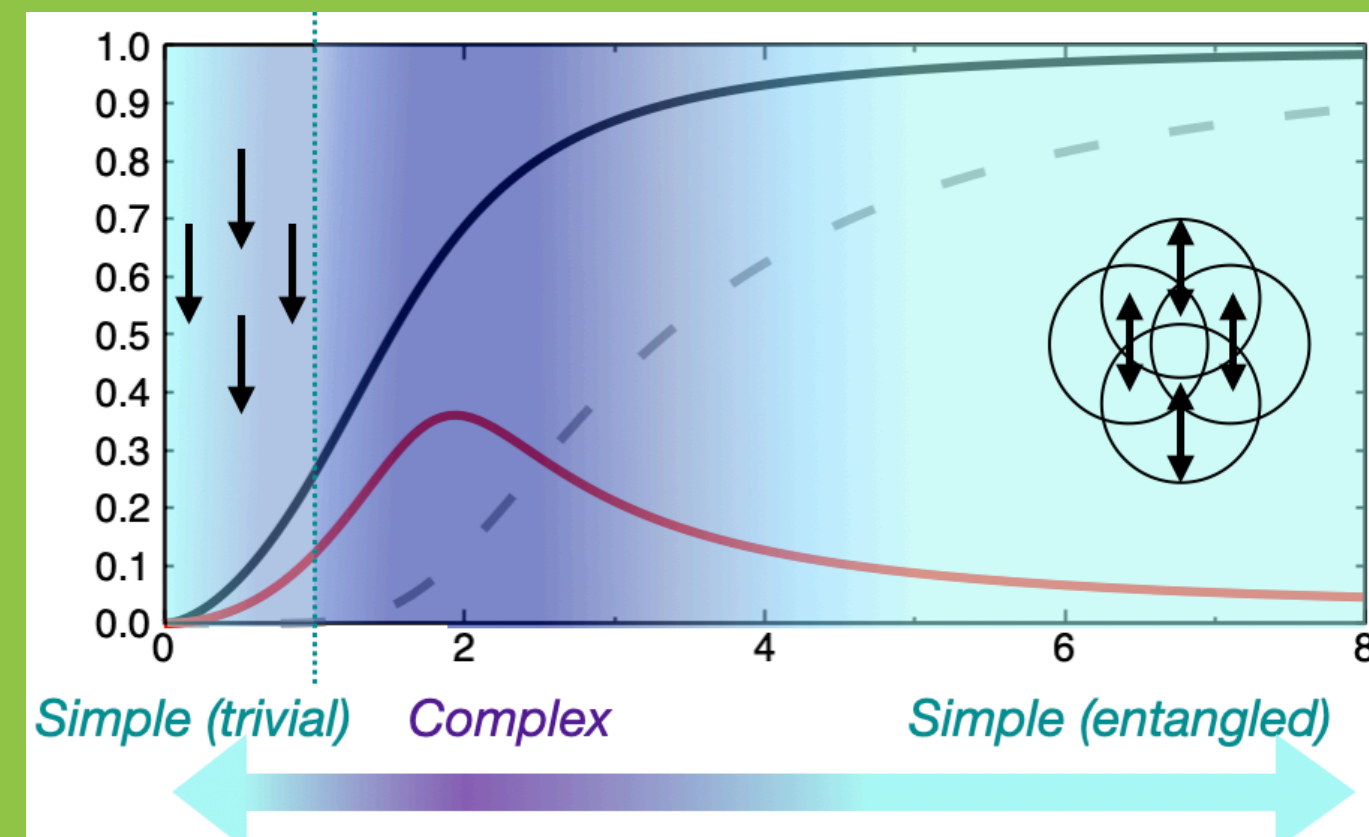

Lectures by Professor Dmitri Kharzeev covered Entanglement wonderfully

A Review

Quantum Complexity and New Directions in Nuclear Physics and High-Energy Physics Phenomenology

Caroline E. P. Robin^{1,2}  and Martin J. Savage^{3b} 

¹ Fakultät für Physik, Universität Bielefeld, D-33615, Bielefeld, Germany.

² GSI Helmholtzzentrum für Schwerionenforschung, Planckstraße 1, 64291 Darmstadt, Germany.

³ InQubator for Quantum Simulation (IQUS), Department of Physics, University of Washington, Seattle, WA 98195, USA.

Abstract. Advances in quantum information science (QIS) are providing transformative insights into the complexity of quantum many-body systems, potentially defining new frontiers in nuclear and high-energy physics. This review explores how QIS-derived techniques are fostering new analytic frameworks and algorithms—both classical and quantum—to tackle (some of the) present barriers to discovery in fundamental physics, with applicability to other science domains. We highlight how these techniques are shedding new light on the structure and dynamics of hadrons, nuclei, matter in extreme conditions, and beyond. Importantly, they are expected to play an essential role in the development of large-scale quantum simulations of such systems, particularly in setting the balance among quantum and classical computational resources.

[arXiv:2604.26376](https://arxiv.org/abs/2604.26376) [quant-ph]

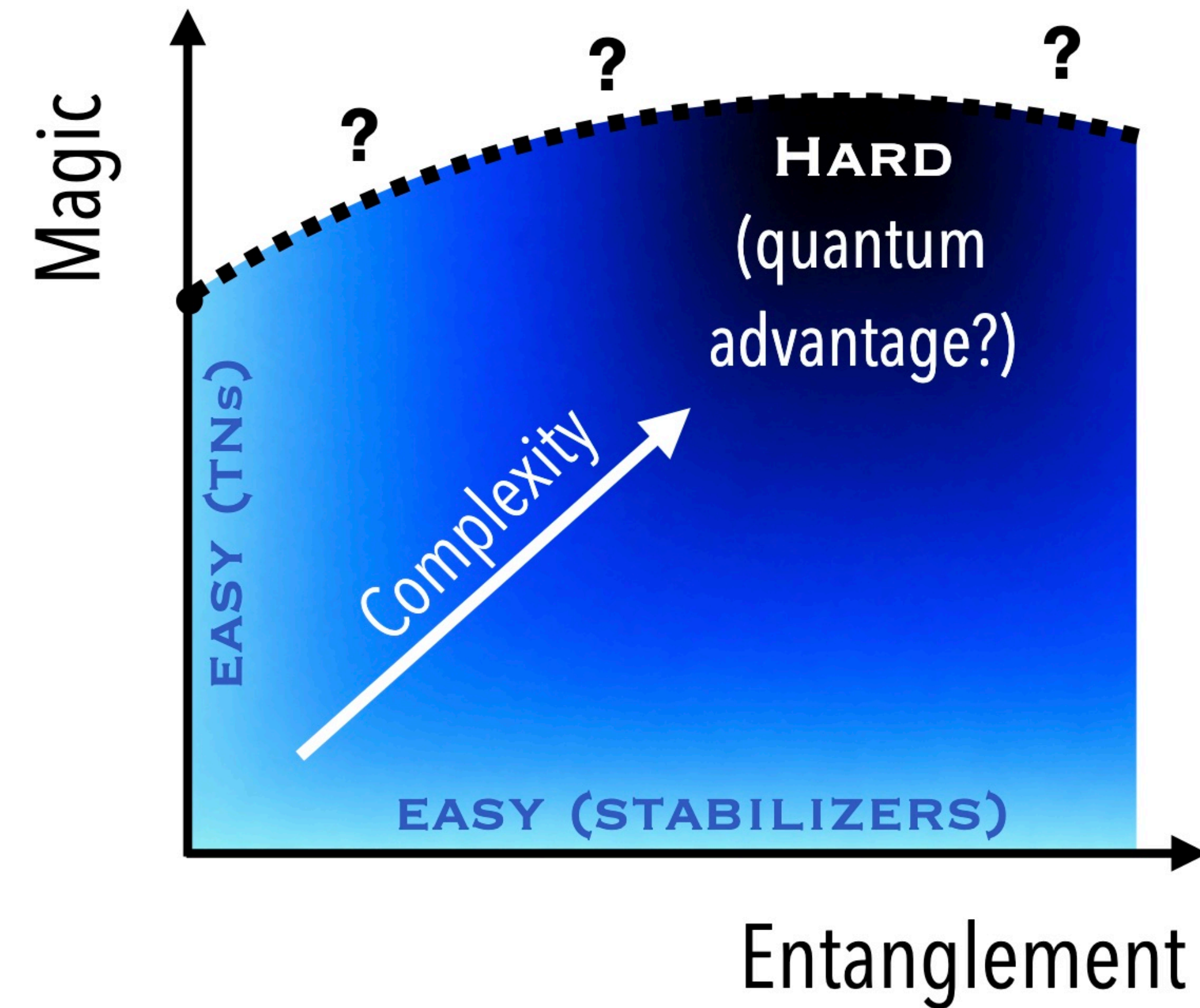

Quantum Complexity Classes - Computer Science Perspective

If $N_{(\text{comp})} = c n N^a$ and $t_{(\text{comp})} = d n t^b$
“asymptotically”
then simulation can be performed
“efficiently”.

The “most general problem”

Subleading is important

BQP: Bounded Quantum Polynomial
- Think “P” and “PSPACE”

QMA: Quantum Merlin Arthur - Think “NP”

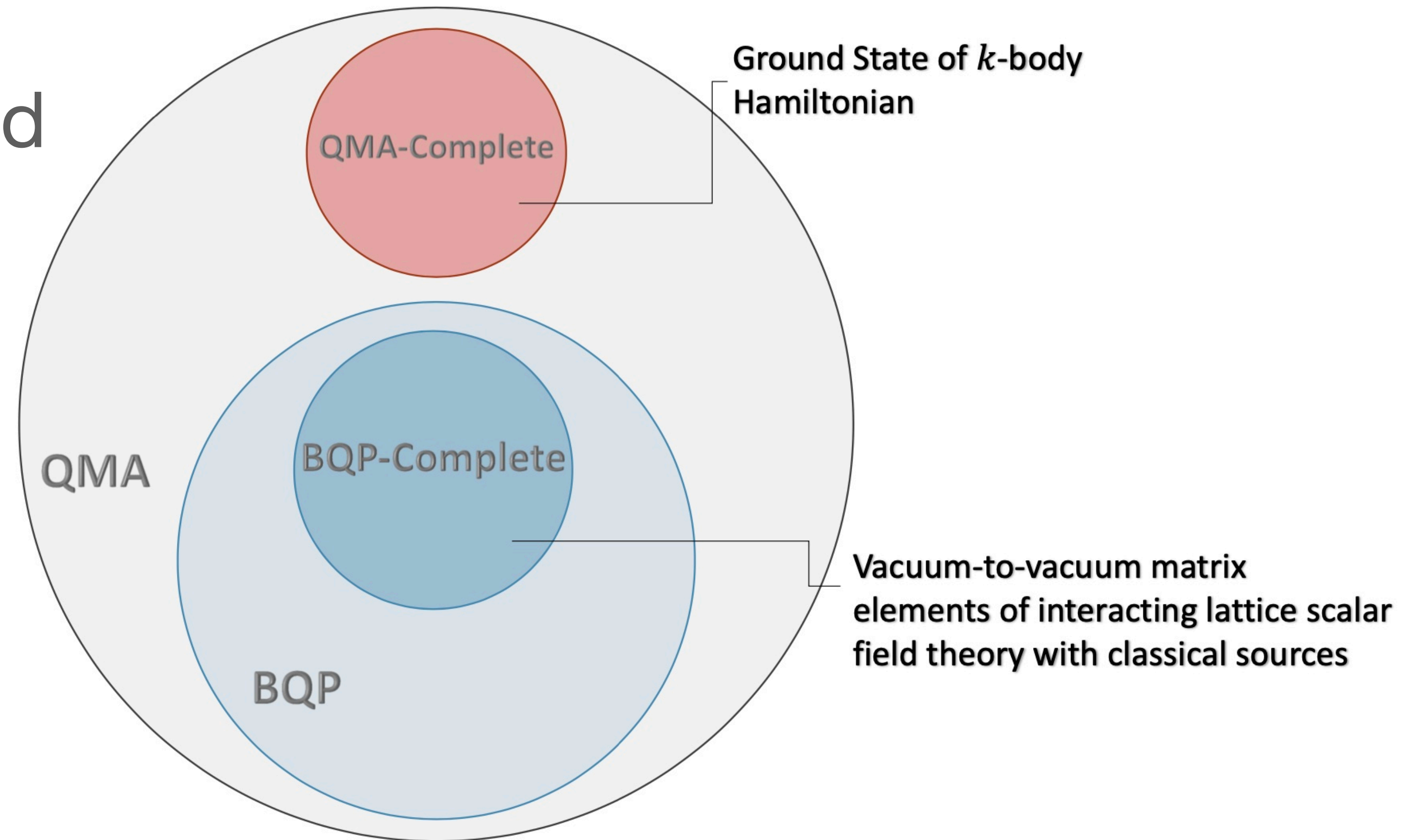

Errors/Uncertainties are a Defining Consideration in Simulations

Theory errors, mapping errors ,
algorithm errors, workflow errors,
device errors, analysis errors

Can find the source(s) of the largest errors
and relax the others.

Exponential improvability is good!

Example sources
of error

Device
Theory/Mapping
Hamiltonian Truncation

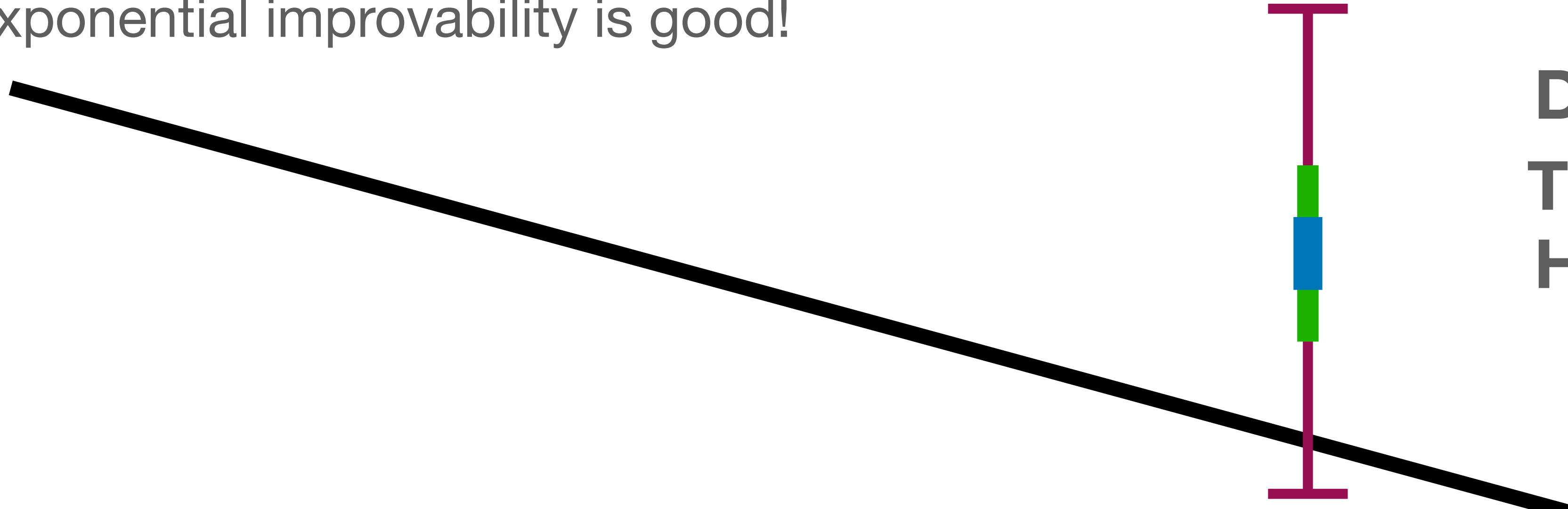

Quantum Complexity Classes - Physicists Perspective

Run science problem (application) on cutting-edge, near-term quantum computer, with finite resources/limited access...

Not asymptotic, optimization trade offs, etc

Wow - that took longer/shorter than we thought it would! ... or... that is a better result than we expected

i.e. benchmarking performance of available hardware, each with distinct limitations

Quantum Complexity measures inform optimization and hybridization

- What to use HPC for and what to use QC for?
- Neutral atom for memory, superconducting for QPU?

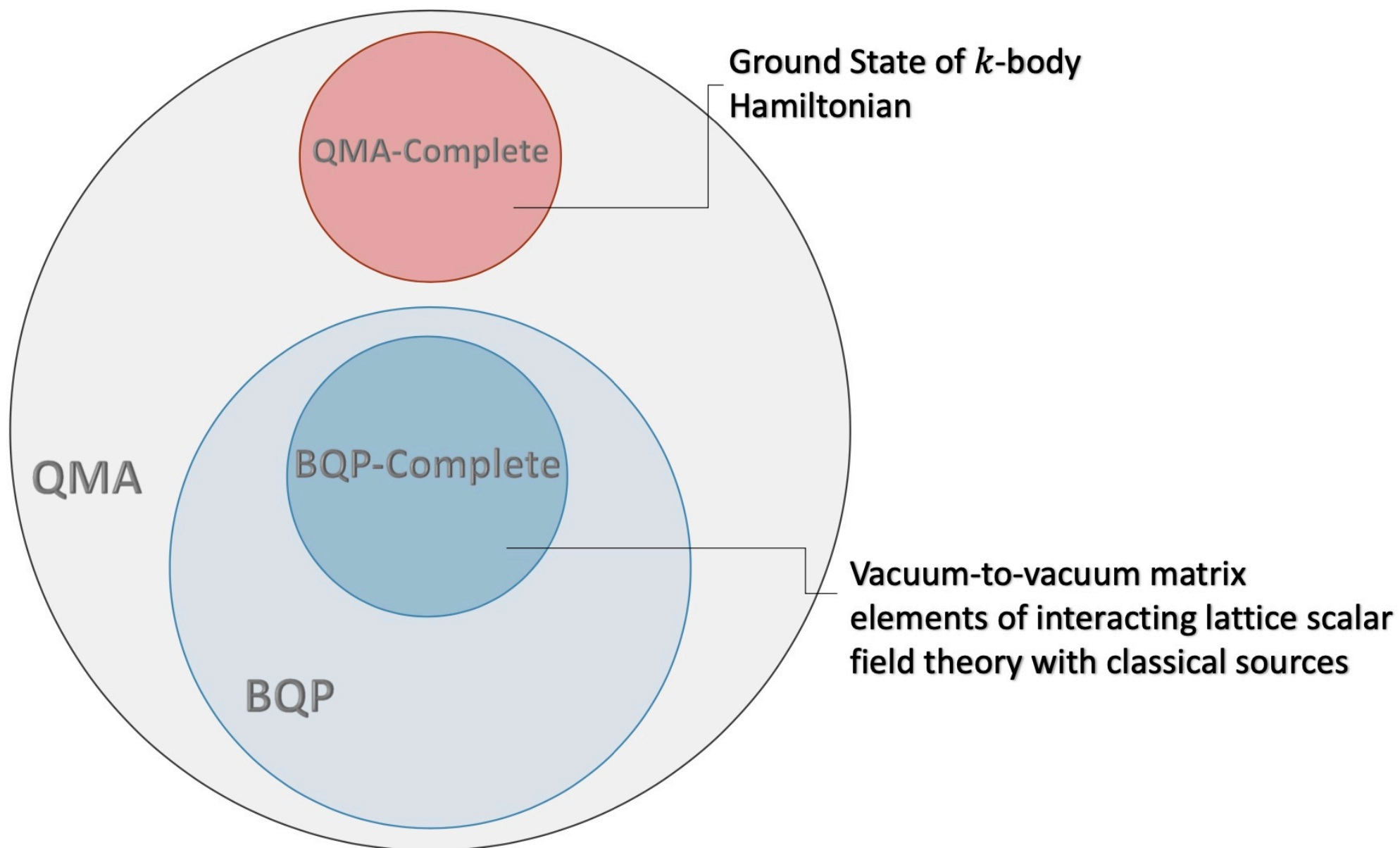

Classical and Universal Quantum Gate Sets

1-Qubit Operations

$$\hat{H} = \frac{1}{\sqrt{2}} \begin{pmatrix} 1 & 1 \\ 1 & -1 \end{pmatrix}, \quad \hat{S} = \begin{pmatrix} 1 & 0 \\ 0 & i \end{pmatrix}, \quad \hat{T} = \begin{pmatrix} 1 & 0 \\ 0 & e^{i\pi/4} \end{pmatrix}$$

2-Qubit Operations

$$\text{CNOT}_{12} = \hat{\Lambda}_0 \otimes \hat{I}_2 + \hat{\Lambda}_1 \otimes \hat{X}$$
$$\hat{\Lambda}_0 = |0\rangle\langle 0|, \quad \hat{\Lambda}_1 = |1\rangle\langle 1|$$

The Clifford Group - maps Paulis to Paulis

Classical and Universal Quantum Gate Sets

1-Qubit Operations

$$\hat{H} = \frac{1}{\sqrt{2}} \begin{pmatrix} 1 & 1 \\ 1 & -1 \end{pmatrix}, \quad \hat{S} = \begin{pmatrix} 1 & 0 \\ 0 & i \end{pmatrix}, \quad \hat{T} = \begin{pmatrix} 1 & 0 \\ 0 & e^{i\pi/4} \end{pmatrix}$$

2-Qubit Operations

$$\begin{aligned} \text{CNOT}_{12} &= \hat{\Lambda}_0 \otimes \hat{I}_2 + \hat{\Lambda}_1 \otimes \hat{X} \\ \hat{\Lambda}_0 &= |0\rangle\langle 0|, \quad \hat{\Lambda}_1 = |1\rangle\langle 1| \end{aligned}$$

The Gottesman-Knill Theorem

1998

The Heisenberg Representation of Quantum Computers

Daniel Gottesman*

Theorem 1 (Knill's theorem) *Any quantum computer performing only: a) Clifford group gates, b) measurements of Pauli group operators, and c) Clifford group operations conditioned on classical bits, which may be the results of earlier measurements, can be perfectly simulated in polynomial time on a probabilistic classical computer.*

Improved Simulation of Stabilizer Circuits

2008

Scott Aaronson*
MIT

Daniel Gottesman†
Perimeter Institute

Clifford Gates
H, S, CNOT

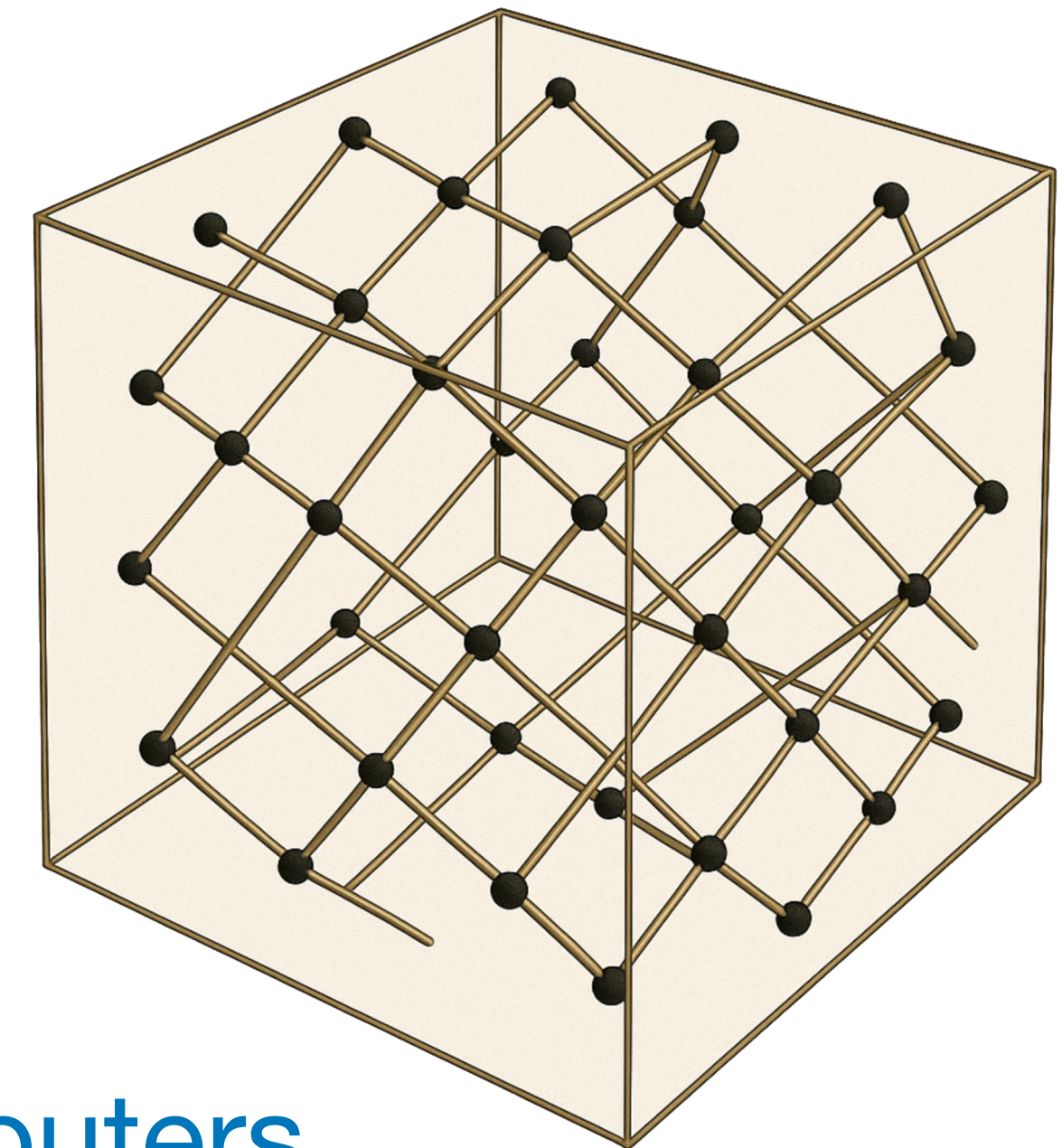

Clifford Circuits can be simulated efficiently with classical computers

Subset of the Hilbert space, including large-scale multi-partite entangled states.

Stabilizer states form a projective 3-design for qubits

$$\frac{1}{|\mathcal{S}|} \sum_{\psi \in \mathcal{S}} (|\psi\rangle\langle\psi|)^{\otimes 3} = \int d\psi (|\psi\rangle\langle\psi|)^{\otimes 3}$$

e.g., 1 and 2-Qubit Stabilizer States

$$\begin{aligned}
 &|0\rangle, \quad |1\rangle && (\pm Z) \\
 &|+\rangle = \frac{1}{\sqrt{2}}(|0\rangle + |1\rangle), \quad |-\rangle = \frac{1}{\sqrt{2}}(|0\rangle - |1\rangle) && (\pm X) \\
 &|+i\rangle = \frac{1}{\sqrt{2}}(|0\rangle + i|1\rangle), \quad |-i\rangle = \frac{1}{\sqrt{2}}(|0\rangle - i|1\rangle) && (\pm Y)
 \end{aligned}$$

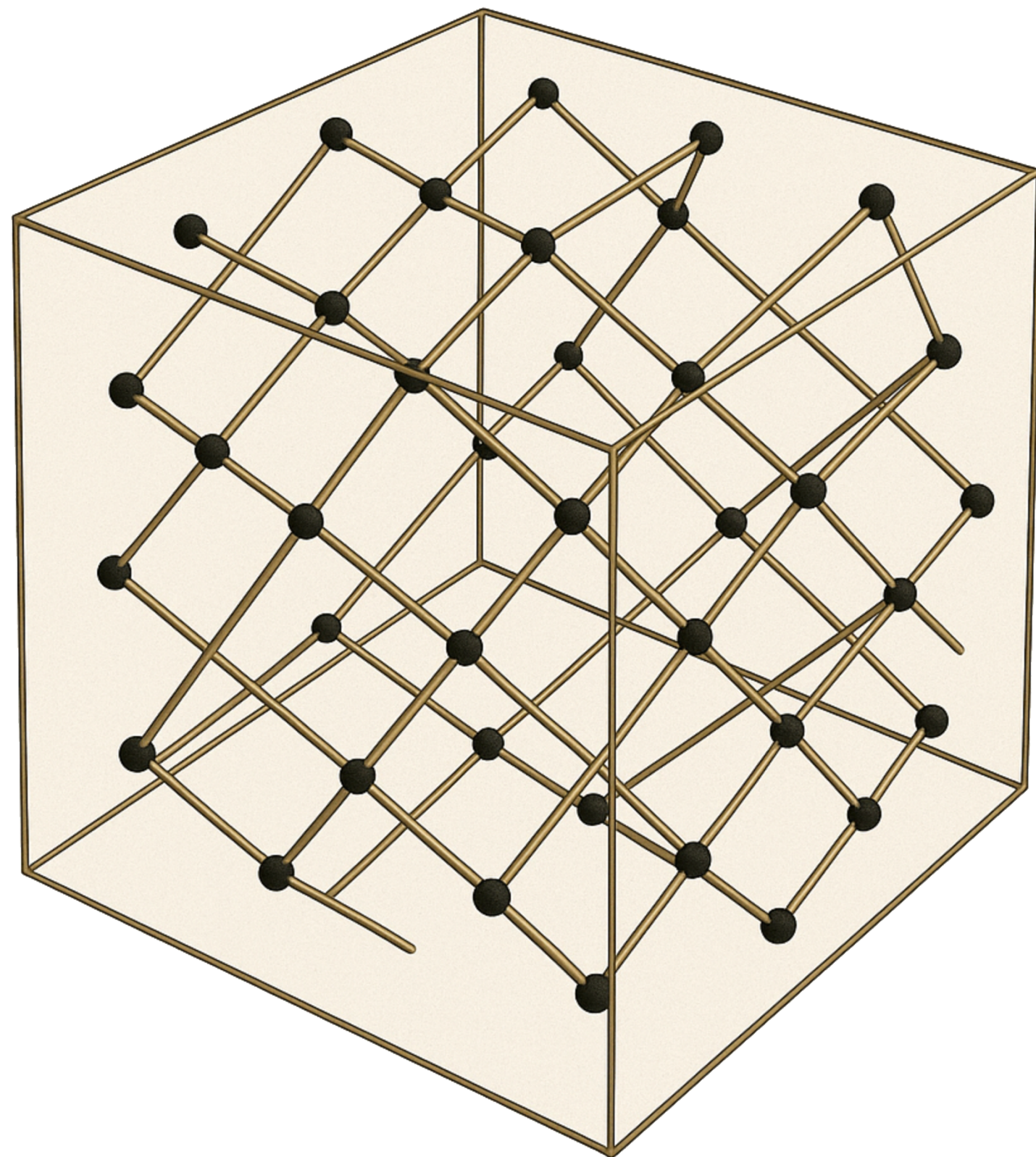

state	00⟩	01⟩	10⟩	11⟩	state	00⟩	01⟩	10⟩	11⟩
1	1	1	1	1	37	0	1	1	0
2	1	-1	1	-1	38	1	0	0	-1
3	1	1	-1	-1	39	1	0	0	1
4	1	-1	-1	1	40	0	1	-1	0
5	1	1	i	i	41	1	0	0	i
6	1	-1	i	-i	42	0	1	i	0
7	1	1	-i	-i	43	0	1	-i	0
8	1	-1	-i	i	44	1	0	0	-i
9	1	1	0	0	45	1	1	1	-1
10	1	-1	0	0	46	1	1	-1	1
11	0	0	1	1	47	1	-1	1	1
12	0	0	1	-1	48	1	-1	-1	-1
13	1	i	1	i	49	1	i	1	-i
14	1	-i	1	-i	50	1	i	-1	i
15	1	i	-1	-i	51	1	-i	1	i
16	1	-i	-1	i	52	1	-i	-1	-i
17	1	i	i	-1	53	1	1	i	-i
18	1	-i	i	1	54	1	1	-i	i
19	1	i	-i	1	55	1	-1	i	i
20	1	-i	-i	-1	56	1	-1	-i	-i
21	1	i	0	0	57	1	i	i	1
22	1	-i	0	0	58	1	i	-i	-1
23	0	0	1	i	59	1	-i	i	-1
24	0	0	1	-i	60	1	-i	-i	1
25	1	0	1	0					
26	0	1	0	1					
27	1	0	-1	0					
28	0	1	0	-1					
29	1	0	i	0					
30	0	1	0	i					
31	1	0	-i	0					
32	0	1	0	-i					
33	1	0	0	0					
34	0	1	0	0					
35	0	0	1	0					
36	0	0	0	1					

Stabilizer States are Special !

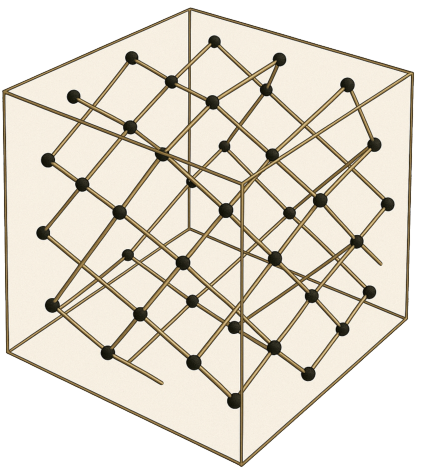

$$N_{\text{stab}} = \mathbf{d}^{n_Q} \prod_{i=1}^n (\mathbf{d}^i + 1)$$

Qubits: $d=2$: 6 for $n_Q=1$, 60 for $n=2$, 1080 for $n_Q=3$, ...

Qutrits: $d=3$: 12 for $n_Q=1$, 360 for $n=2$, 30240 for $n_Q=3$, ...

$d=\text{prime}$: stabilizer states == undirected graphs

$$P = \{ \hat{X}, \hat{Y}, \hat{Z}, \hat{I} \}$$

$$\hat{\rho} = \frac{1}{d} \sum_P c_P \hat{P} \quad , \quad \hat{P} = P_{i_1} \otimes P_{i_2} \otimes \dots \otimes P_{i_{n_Q}}$$

$$c_P = \text{Tr} \left[\hat{\rho} \hat{P} \right] = \langle \psi | \hat{P} | \psi \rangle .$$

For stabilizer states: 2^n of the P have $|c_P| = 1$ and $4^n - 2^n$ have $|c_P| = 0$

$$\Xi_P = c_P^2 / d \quad \sum_P \Xi_P = 1$$

Magic Measures

$$\hat{\rho} = |\psi\rangle\langle\psi| = \frac{1}{\mathbf{d}} \sum_{\hat{P}} \langle\psi|\hat{P}|\psi\rangle \hat{P} = \frac{1}{\mathbf{d}} \sum_{\hat{P}} c_P \hat{P}, \quad \Xi_P = c_P^2/d$$

$$\mathcal{M}_\alpha(|\psi\rangle) = -\log_2 \mathbf{d} + \frac{1}{1-\alpha} \log_2 \left(\sum_{\hat{P}} \Xi_{\hat{P}}^\alpha \right), \quad \mathcal{M}_2 = -\log_2 \mathbf{d} \sum_{\hat{P}} \Xi_{\hat{P}}^2. \quad \text{Magic}$$

$\alpha < 1$ # of stabilizers

$\alpha > 1$ distance to nearest stabilizer

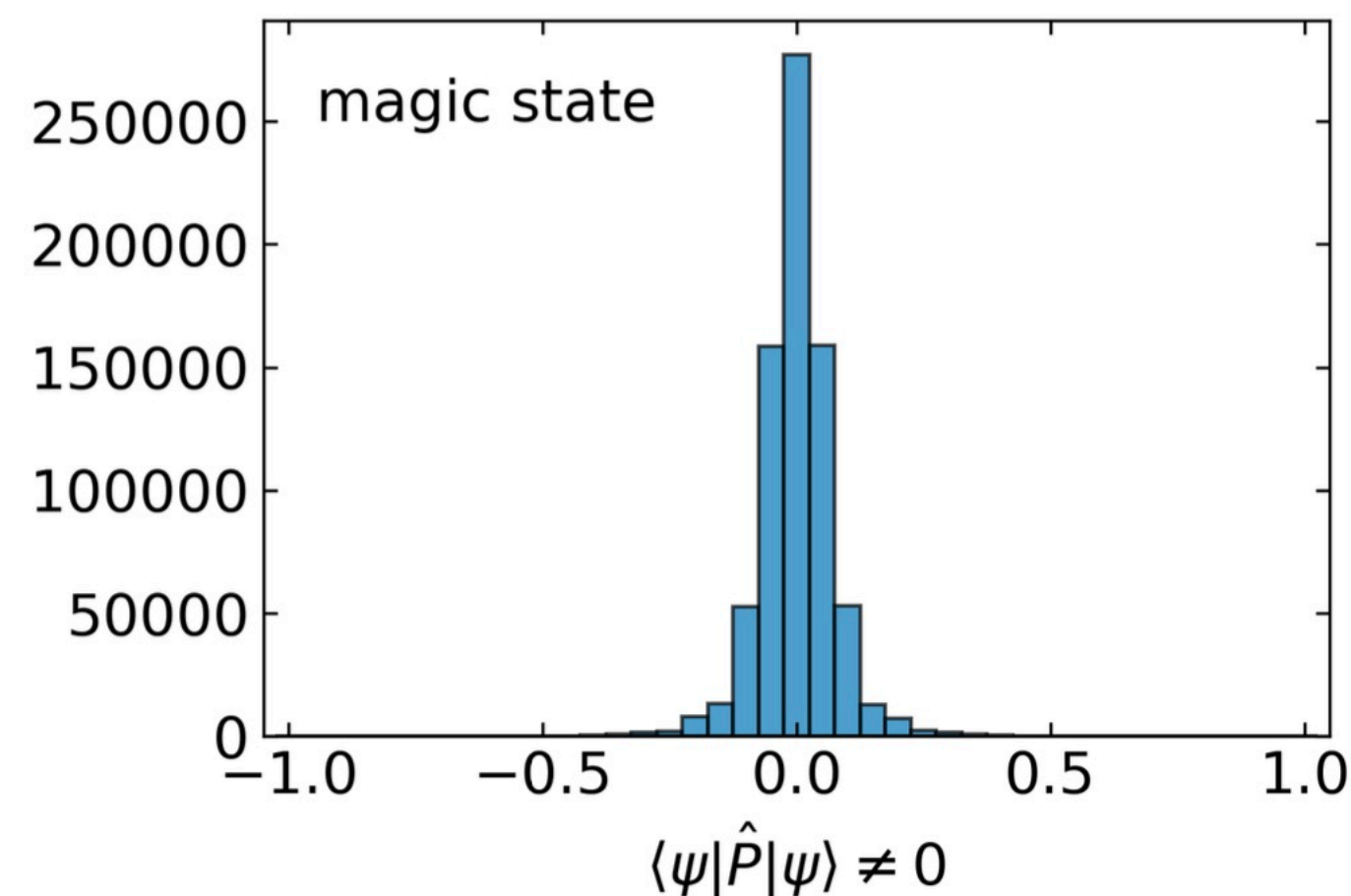
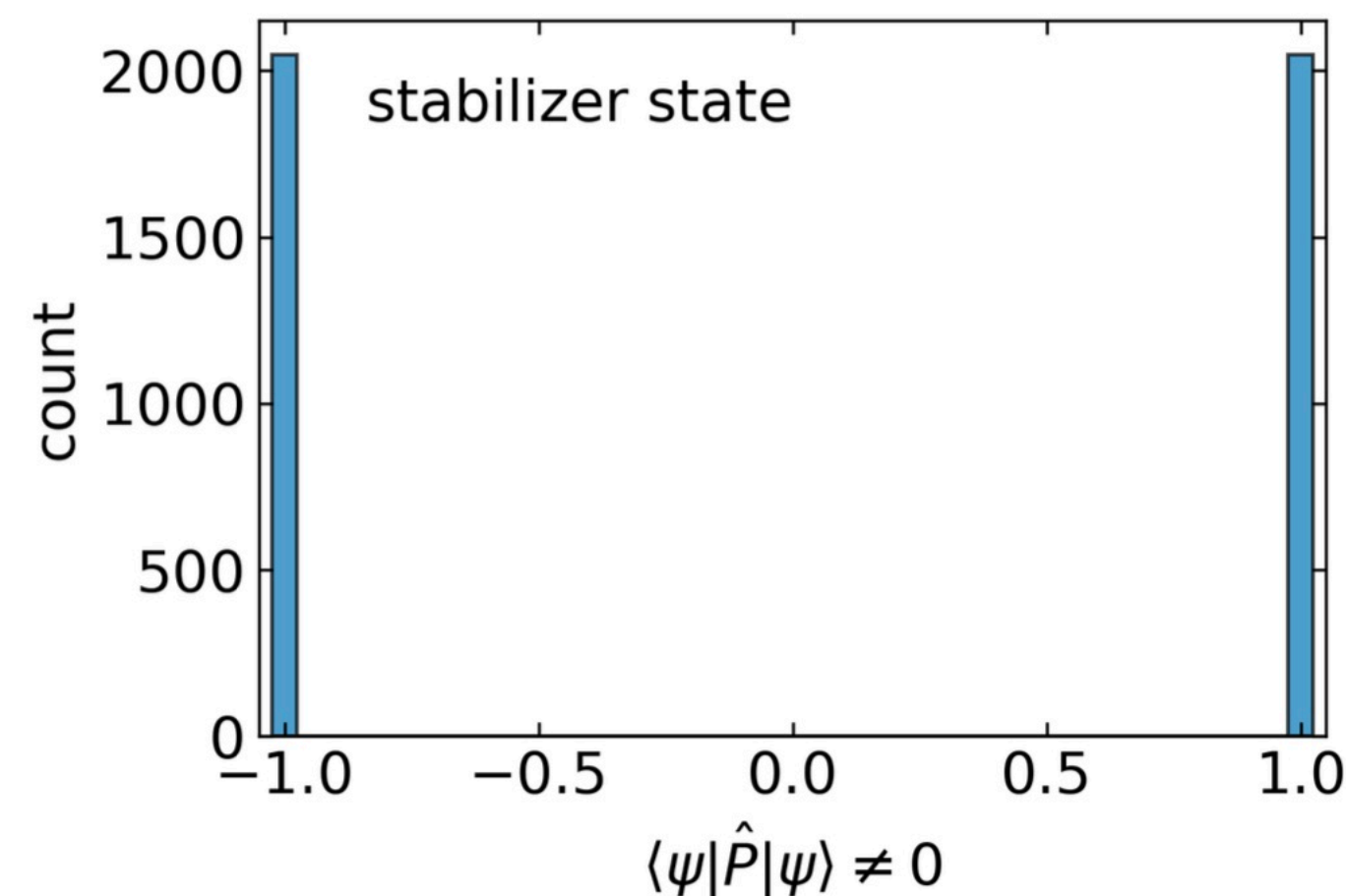

Magic in 1 Qubit

$$|\psi\rangle = \alpha|0\rangle + \beta e^{i\phi}|1\rangle, \quad \rho = \begin{pmatrix} \alpha^2 & \alpha\beta e^{i\phi} \\ \alpha\beta e^{-i\phi} & \beta^2 \end{pmatrix}$$

$$c_{\hat{I}} = 1 = \alpha^2 + \beta^2, \quad c_{\hat{Z}} = \alpha^2 - \beta^2, \quad c_{\hat{X}} = 2\alpha\beta \cos \phi, \quad c_{\hat{Y}} = -2\alpha\beta \sin \phi$$

(a)

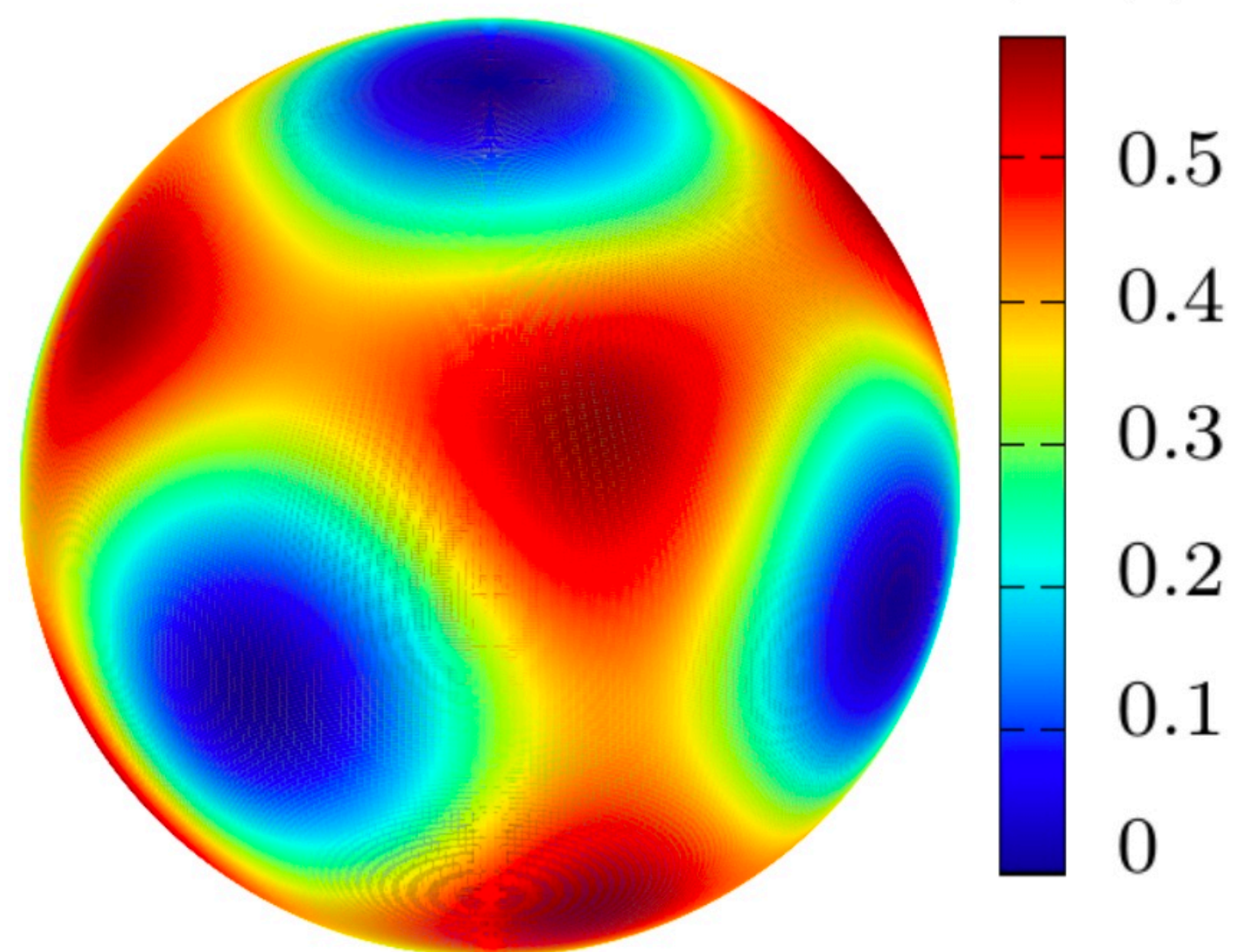

(b)

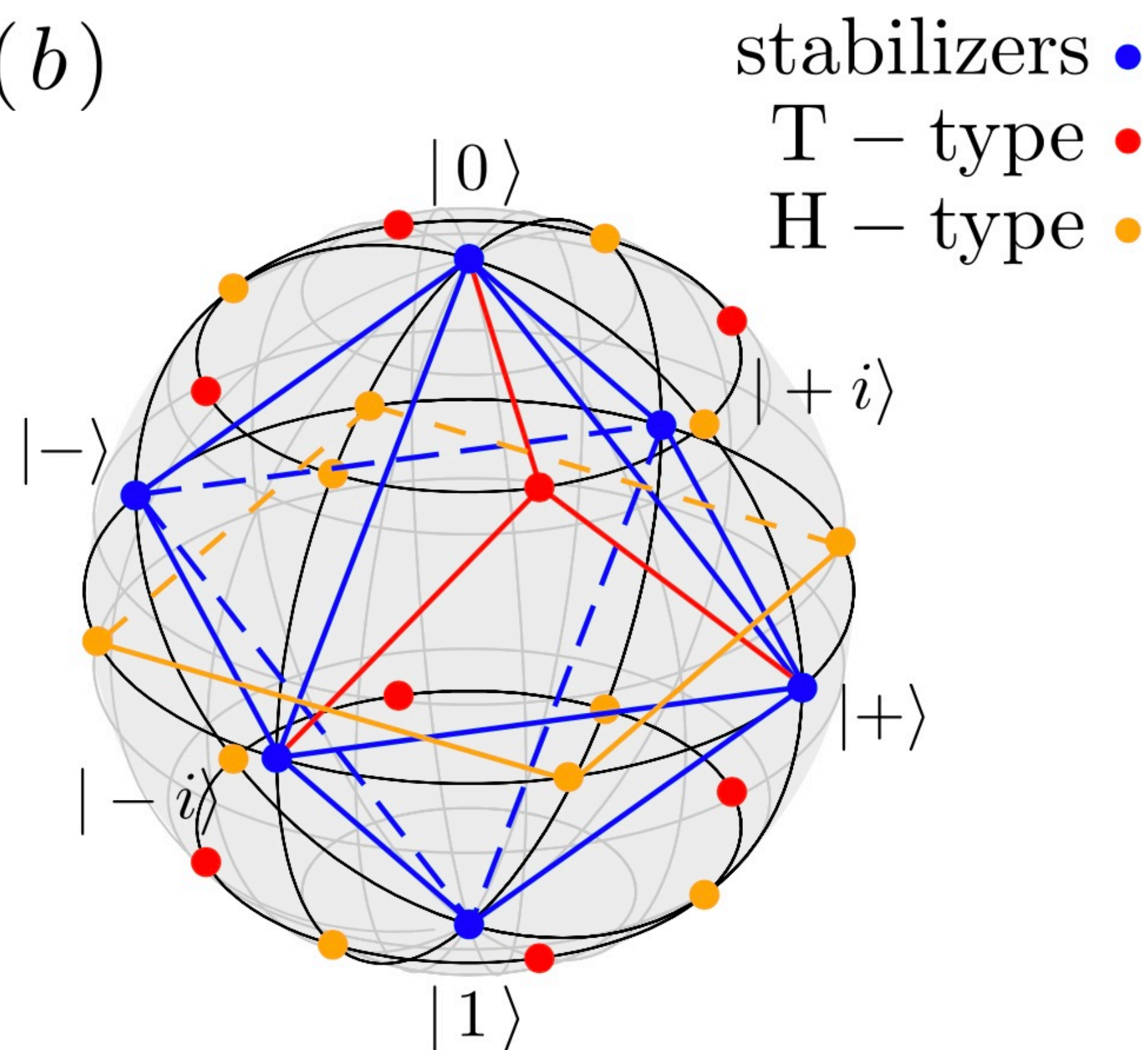

When is a Quantum Computer Required?

Quantum Complexity of Physical Systems?



$$M_2(\theta, \phi)$$

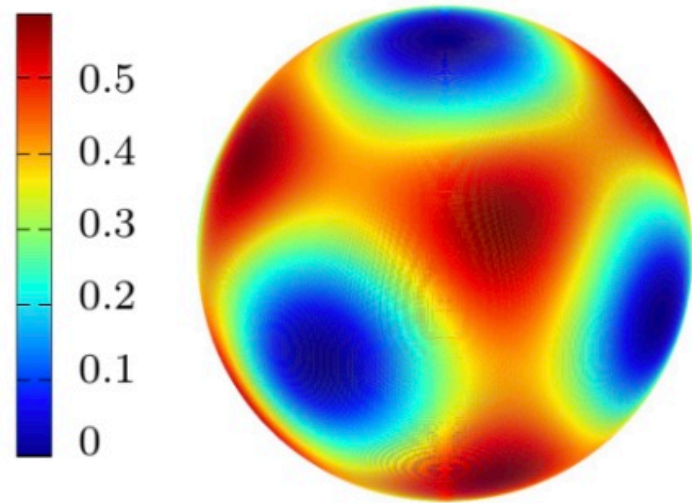

How far from
"Classically Easy"
Is the state

Classical gate set
operations

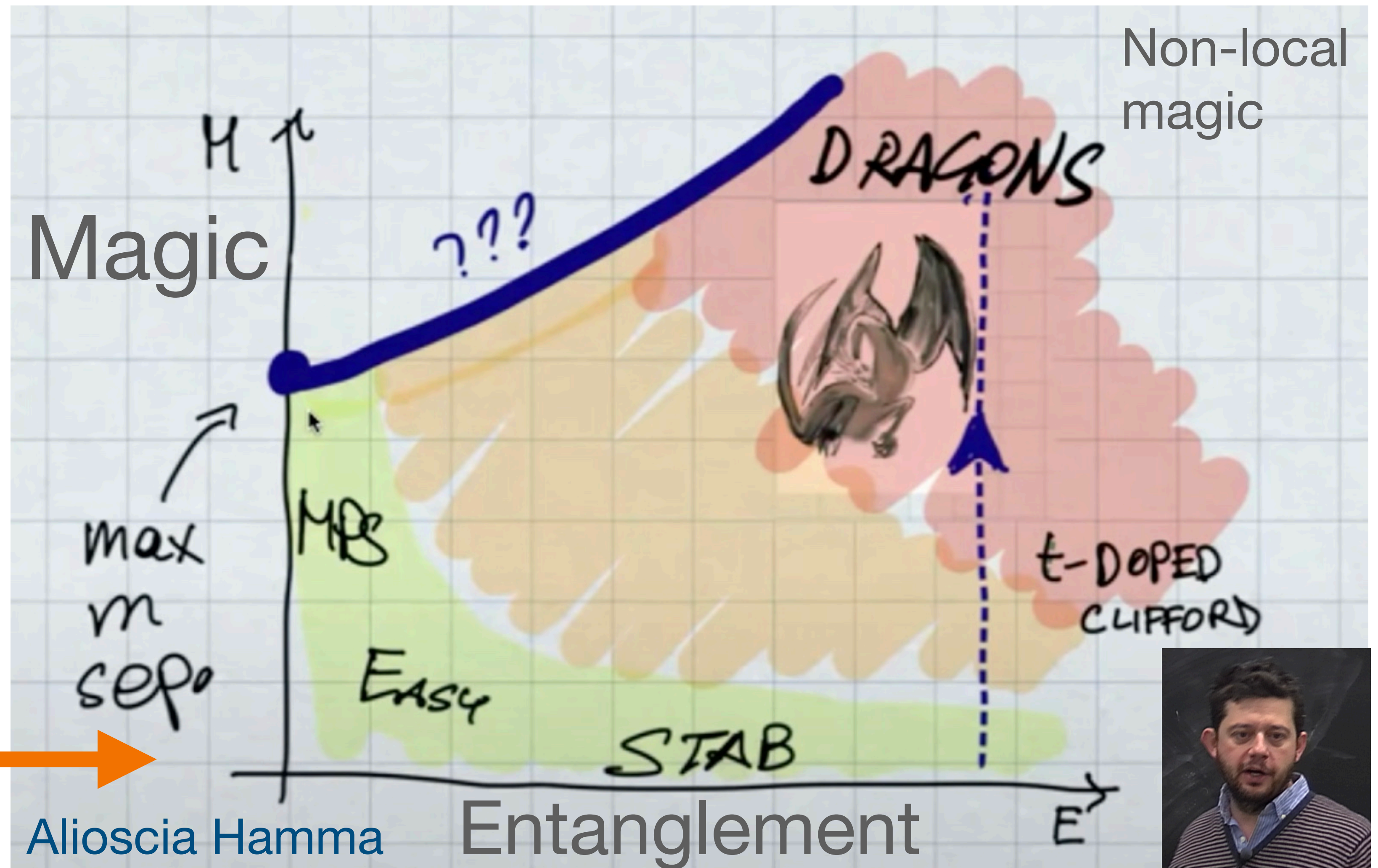
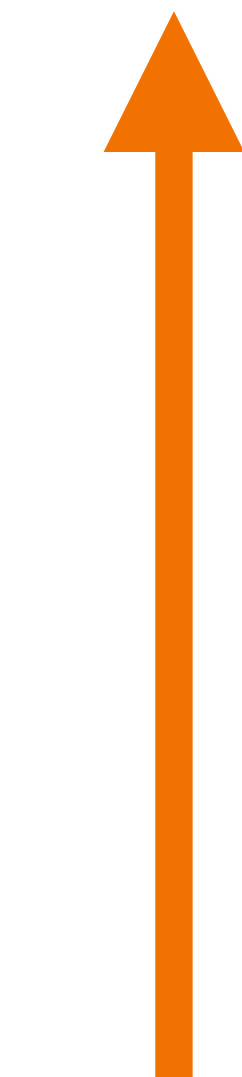

When is a Quantum Computer Required?

Quantum Complexity of Physical Systems?

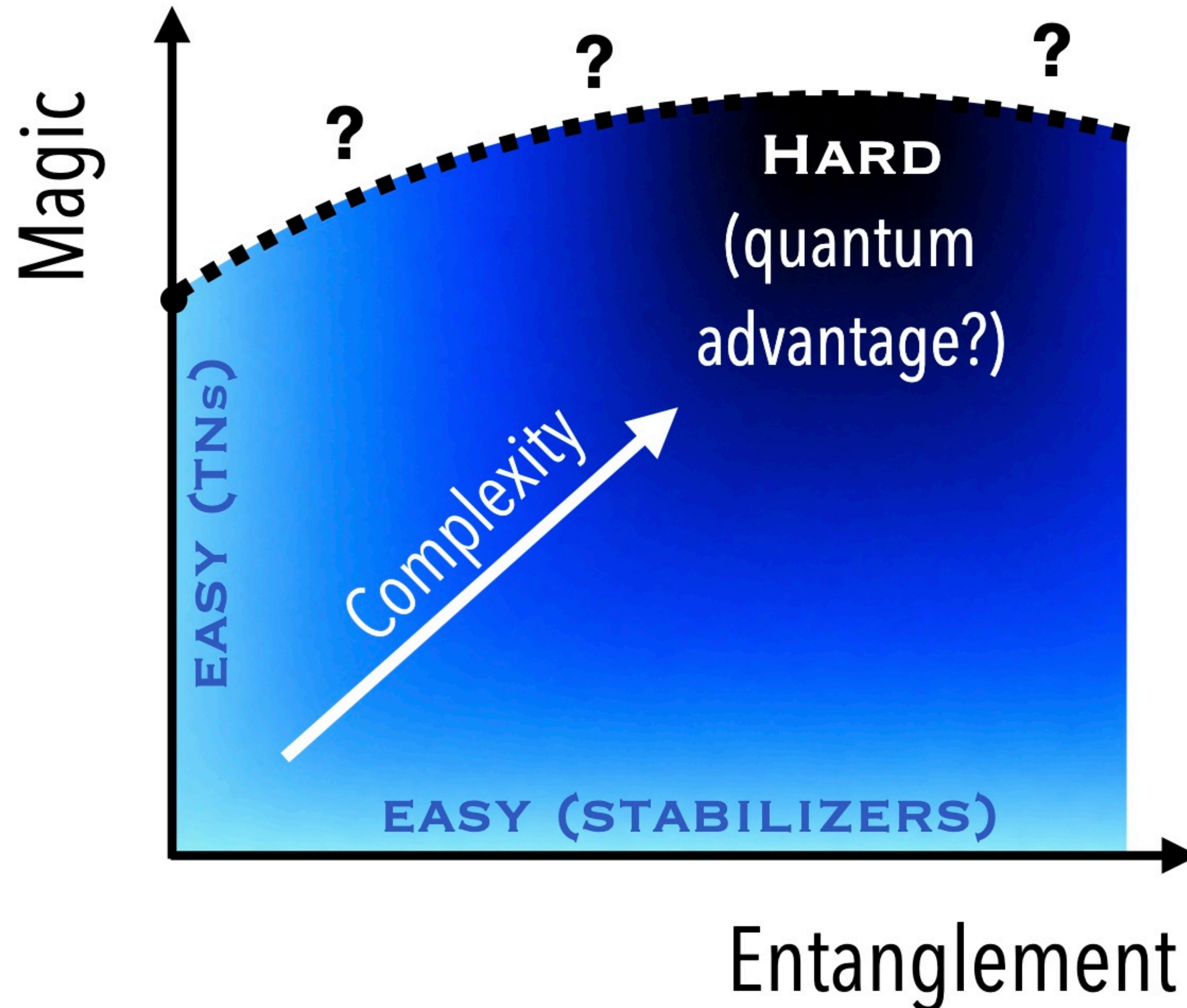

Non-Local Magic - Looking for Dragons

$$\mathcal{M}_\alpha^{(NL)}(|\Psi\rangle) = \min_{U_{A_1} \otimes \dots \otimes U_{A_M}} \mathcal{M}_\alpha(U_{A_1} \otimes \dots \otimes U_{A_M} |\Psi\rangle)$$

$$\mathcal{M}_2^{NL}(|\psi\rangle_{AB}) \leq \mathcal{M}_2(\{\lambda_i\})$$

Saturates in all numerical experiments

$$\mathcal{M}_2(\{\lambda_i\}) = -\log \left(\sum_{i_1, i_2, i_3, i_4=0}^{2^n-1} \sqrt{\lambda_{i_1} \lambda_{i_2} \lambda_{i_3} \lambda_{i_4} \lambda_{i_3 \wedge i_2 \wedge i_1}} \right. \\ \left. \times \sqrt{\lambda_{i_4 \wedge i_2 \wedge i_1} \lambda_{i_1 \wedge i_3 \wedge i_4} \lambda_{i_2 \wedge i_3 \wedge i_4}} \right),$$

U_A (angles(A))

U_B (angles(B))

A

B

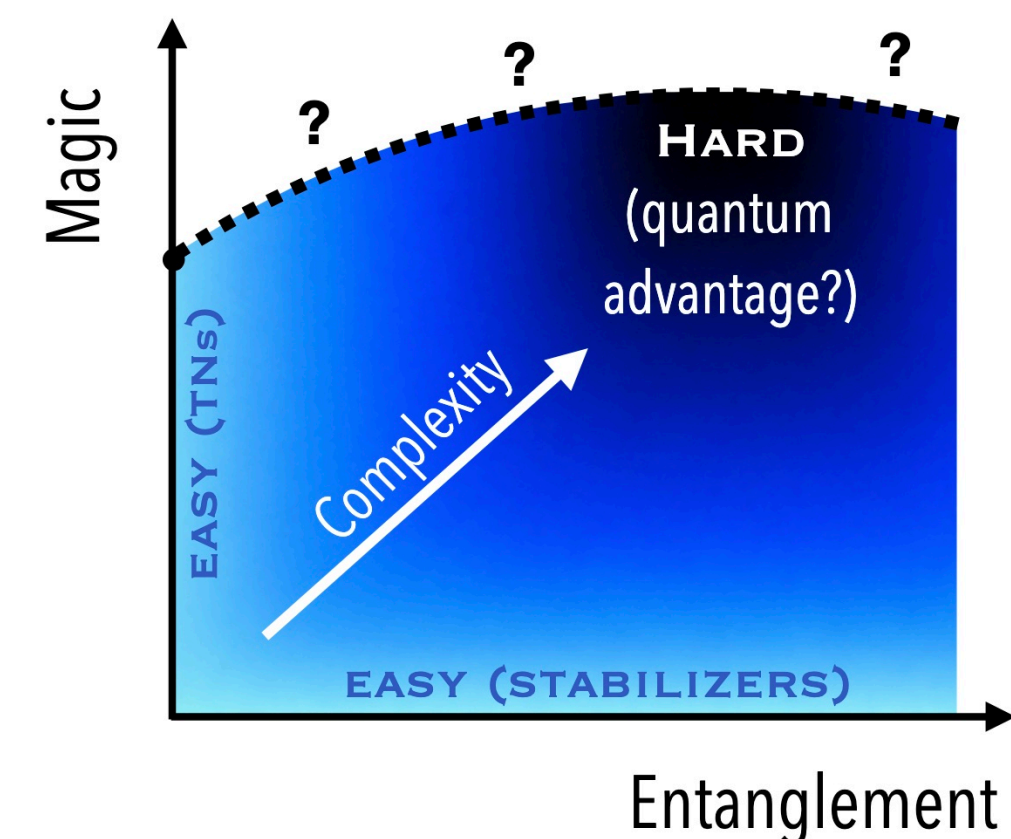

Local and Non-Local Robustness of Magic

$$R(\hat{\rho}) = \min_{\mathbf{x}} \left\{ \|\mathbf{x}\|_1 \mid \hat{\rho} = \sum_i x_i \hat{\rho}_{s_i} \right\} \quad \|\mathbf{x}\|_1 = 1 + 2 \sum_{i \mid \forall x_i < 0} |x_i|$$

and the corresponding non-local minimization

- numerically challenging due to number of stabilizers
- Valid for both pure and mixed states
- Require an optimization for x_i , and non-local require further optimizations.

If $R=1$, then the x_i form a probability distribution and can be sampled classically without a sign problem.

$R>1$ indicates 1 or more negative x_i and a growing sign problem

Qubits and Qutrits

2-Qubits or Qutrit wave functions randomly-selected wave functions
(Haar measure)

$$dU = d(VU) = d(UV) \quad \text{for all } V \in U(d), \quad \int_{U(d)} dU = 1$$

Qubits

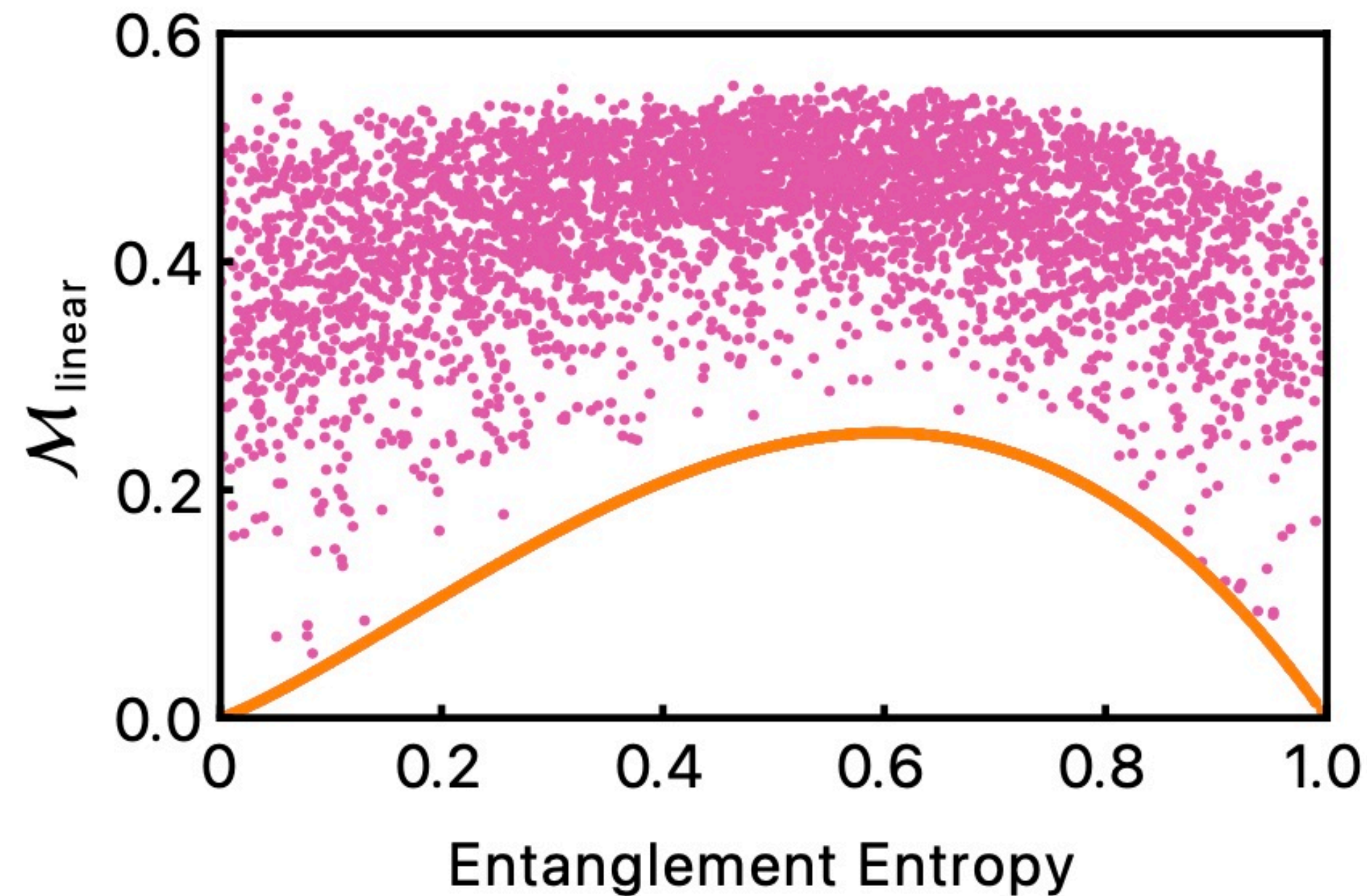

Qutrits

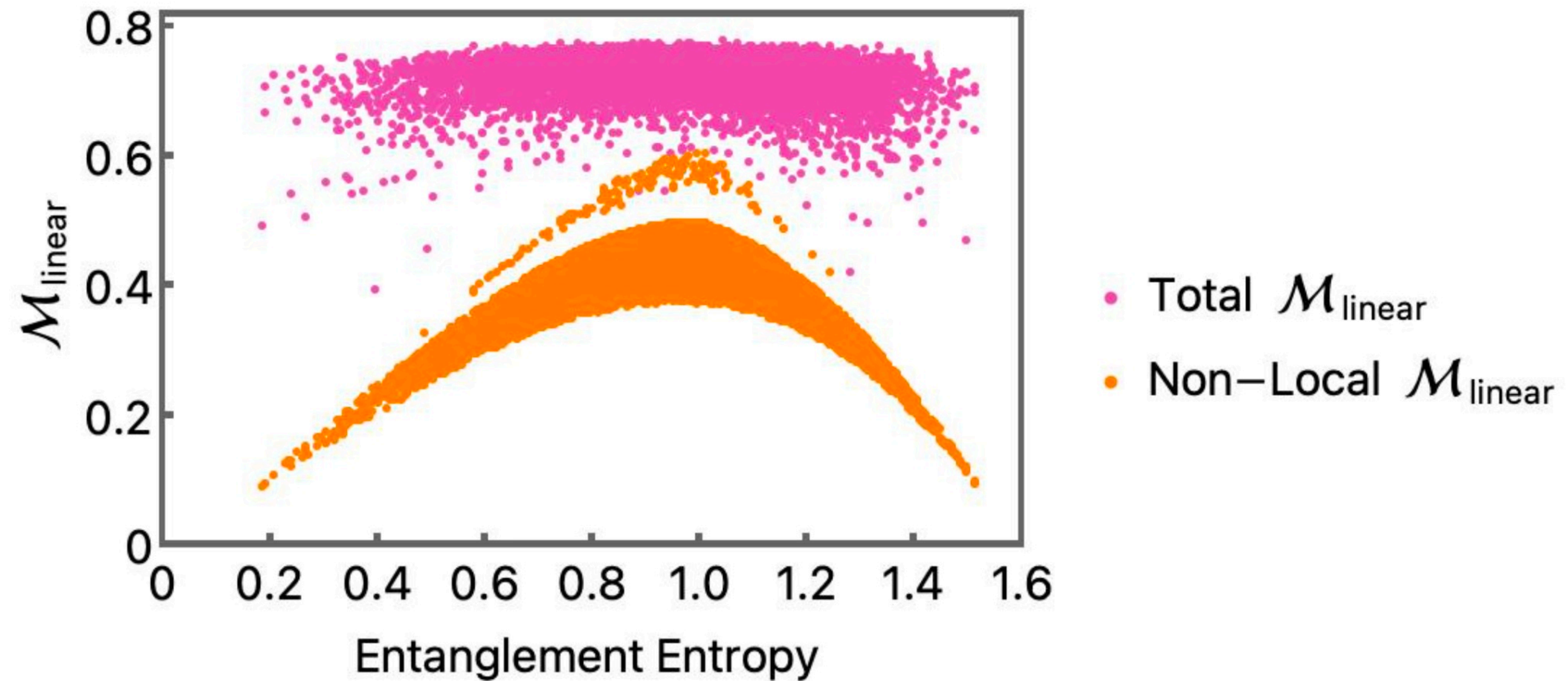

Entanglement and Magic Phase Transitions

Entanglement–magic separation in hybrid quantum circuits

Gerald E. Fux¹, Emanuele Tirrito^{1,2}, Marcello Dalmonte^{1,3} and Rosario Fazio^{1,4}

¹The Abdus Salam International Center for Theoretical Physics (ICTP), Strada Costiera 11, 34151 Trieste, Italy

²Pitaevskii BEC Center, CNR-INO and Dipartimento di Fisica, Università di Trento, Via Sommarive 14, Trento, I-38123, Italy

³Scuola Internazionale Superiore di Studi Avanzati (SISSA), Via Bonomea 265, 34136 Trieste, Italy

⁴Dipartimento di Fisica “E. Pancini”, Università di Napoli “Federico II”, Monte S. Angelo, I-80126 Napoli, Italy

(Dated: December 12, 2023)

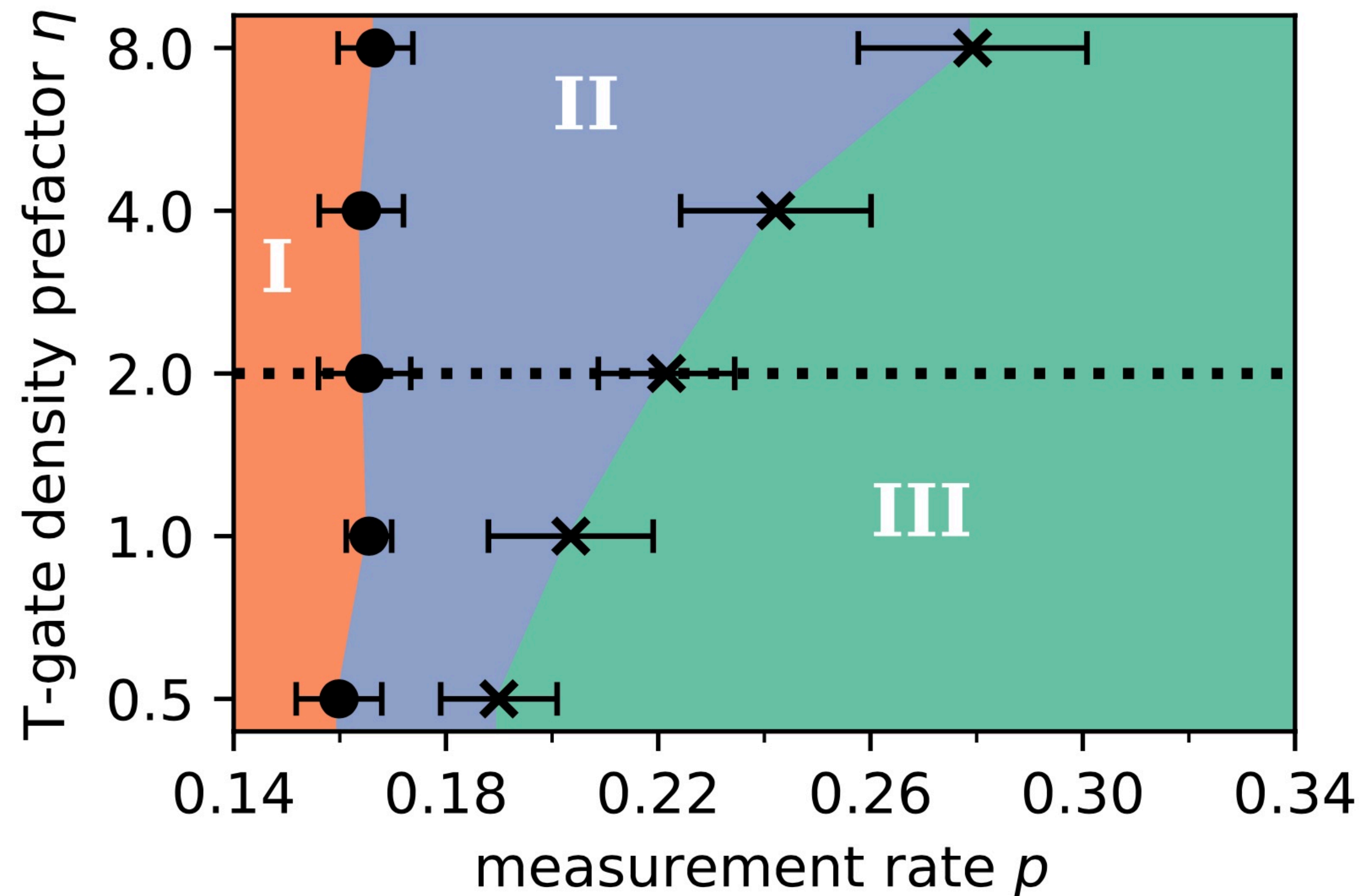
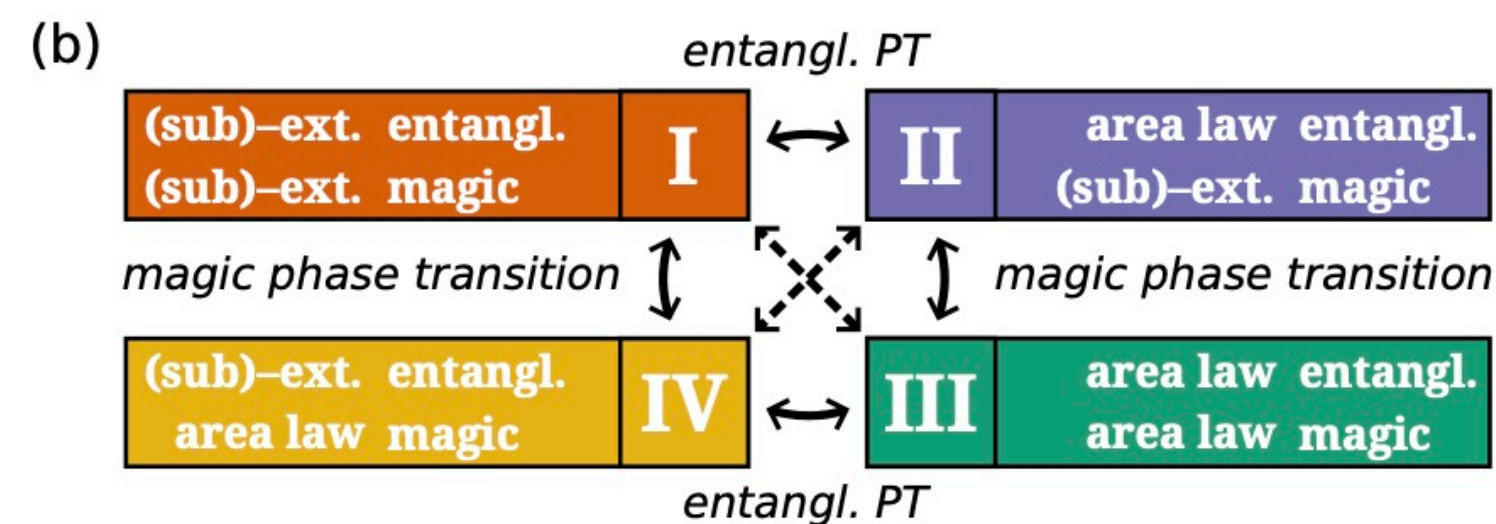
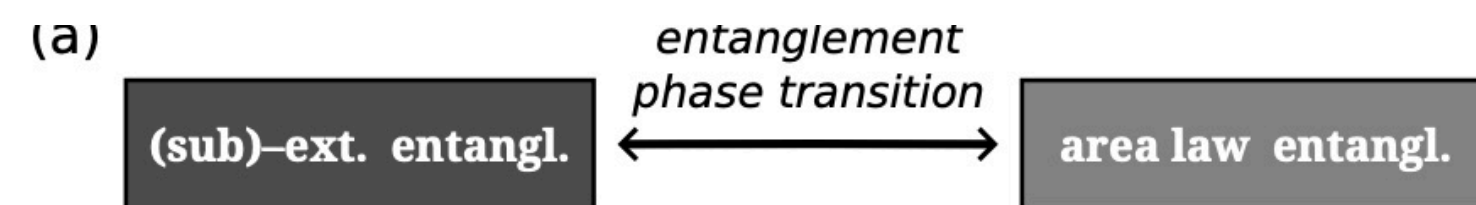
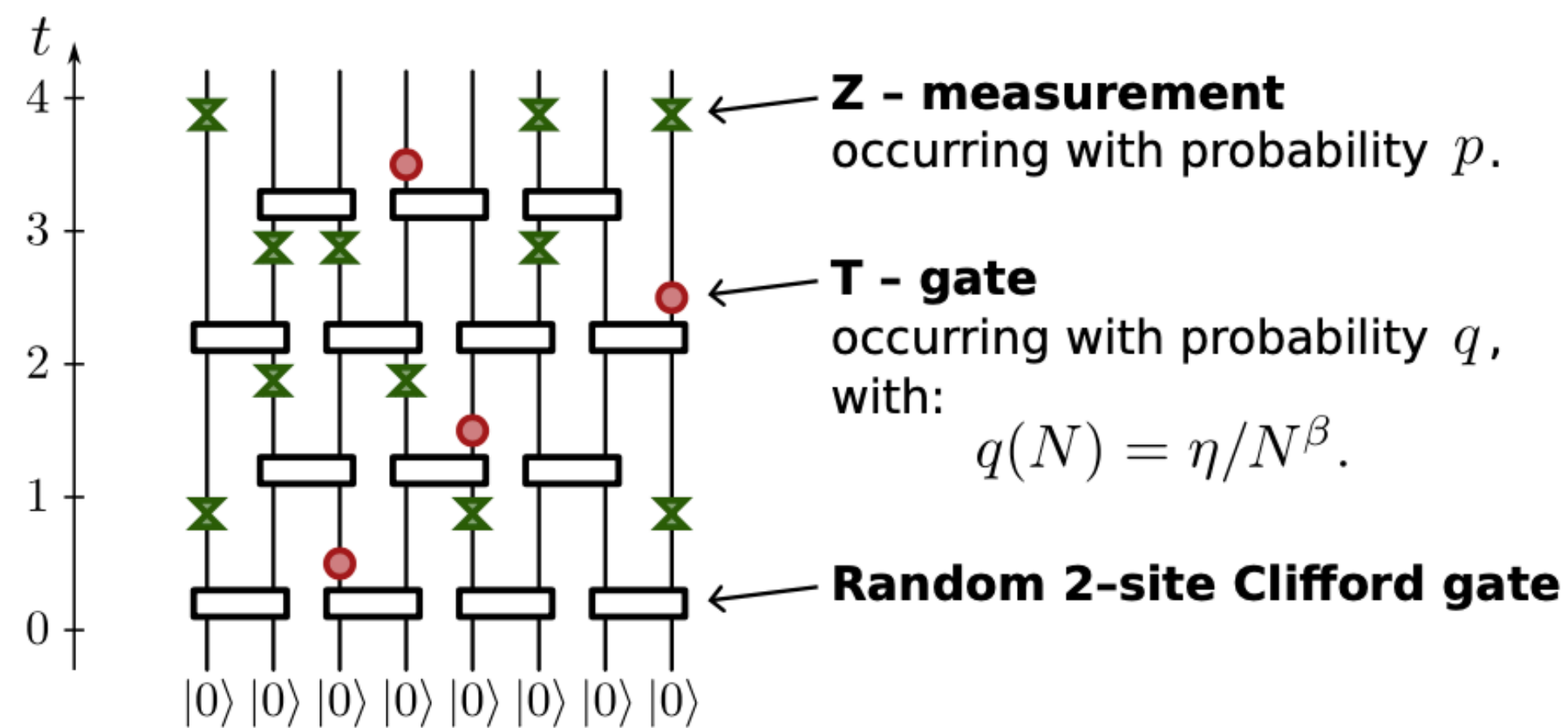

Complexity Barriers

The Magic Barrier before Thermalization

Lukas Ebner,^{1,2} Berndt Müller,³ Andreas Schäfer,^{4,5} Leonhard Schmotzer,⁴ Clemens Seidl,^{4,*} and Xiaojun Yao⁶

2025

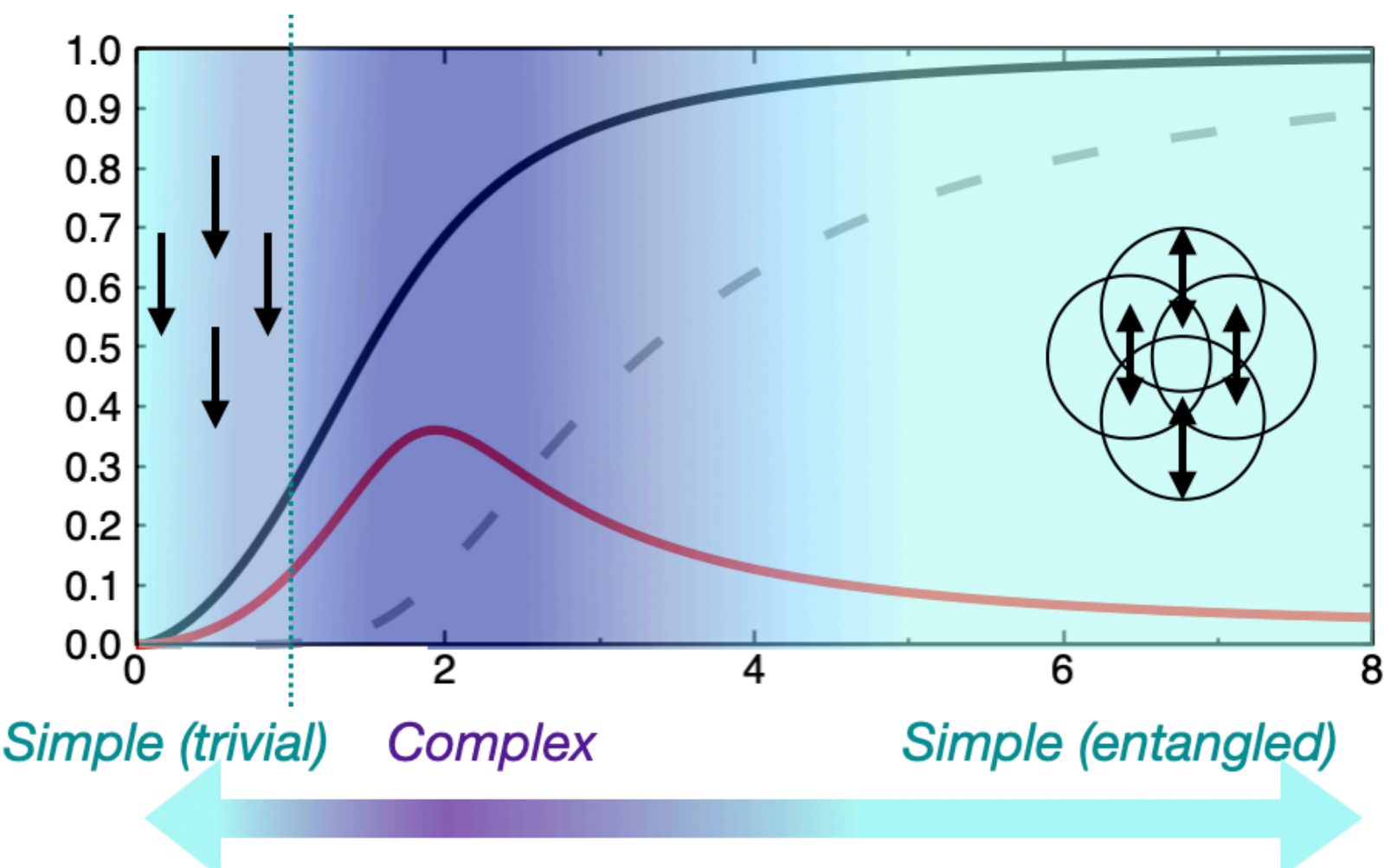
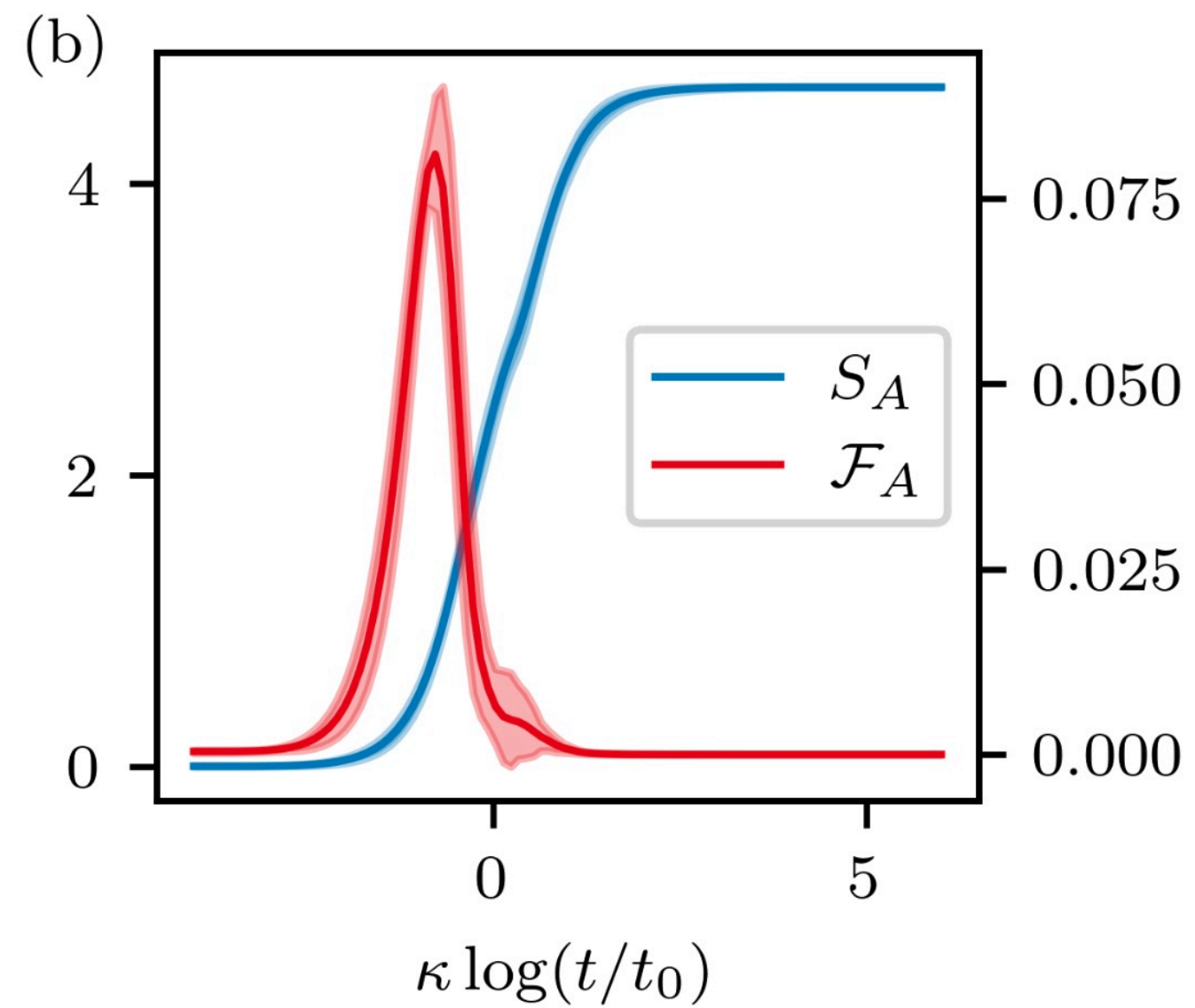
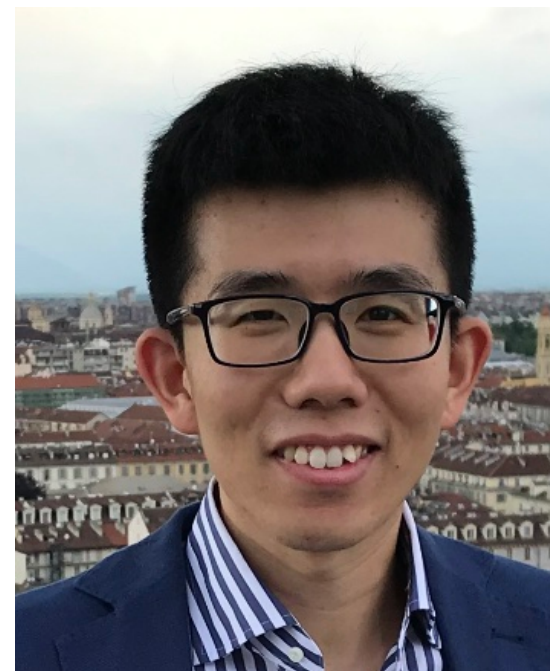

Lipkin Model

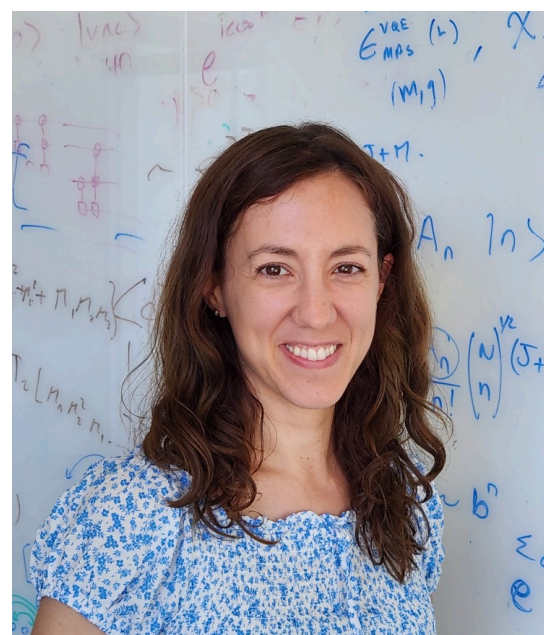

Quantifying the Rise and Fall of Complexity in Closed Systems: The Coffee Automaton

Scott Aaronson*

Sean M. Carroll†

Lauren Ouellette‡

2014

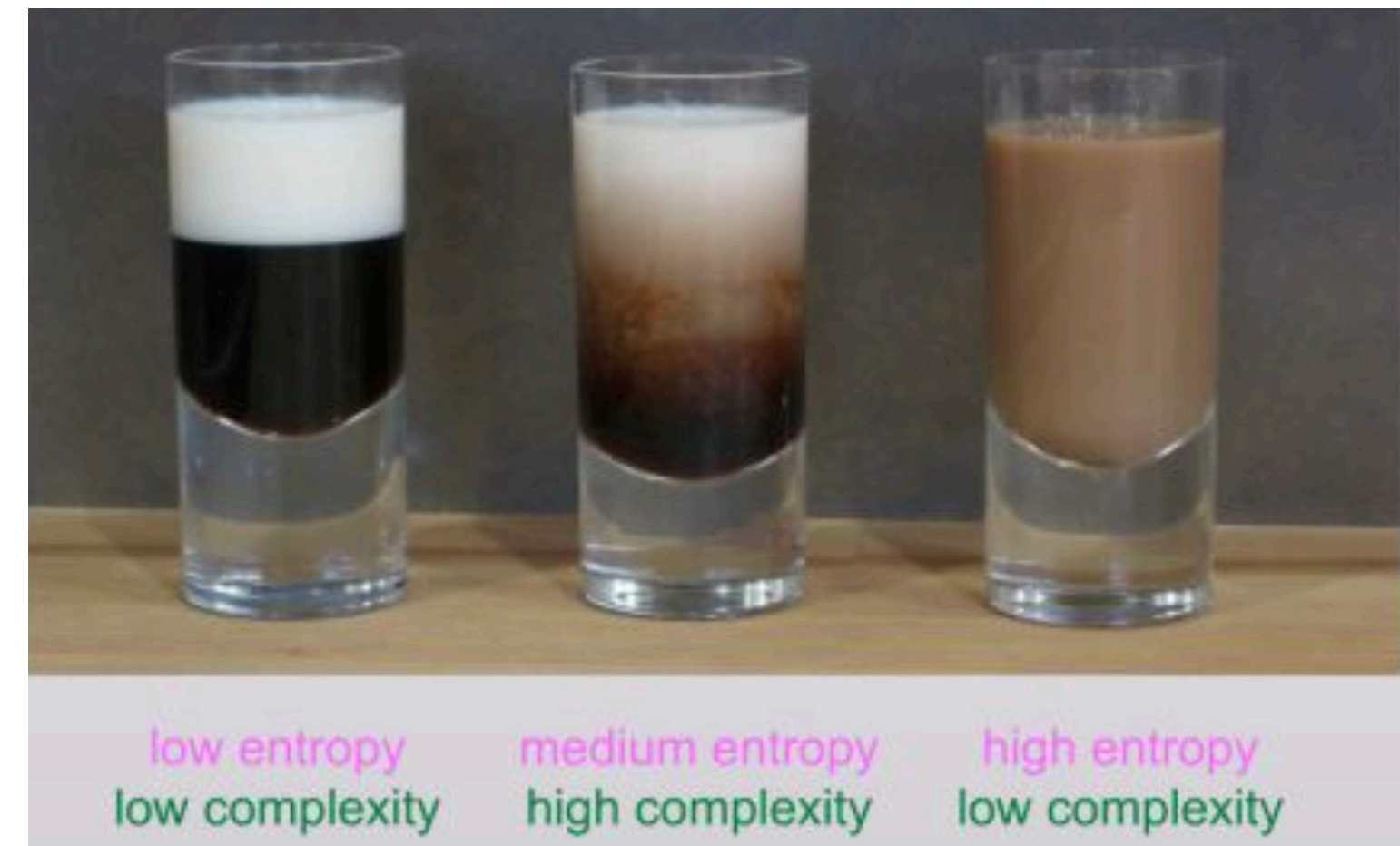

low entropy
low complexity

medium entropy
high complexity

high entropy
low complexity

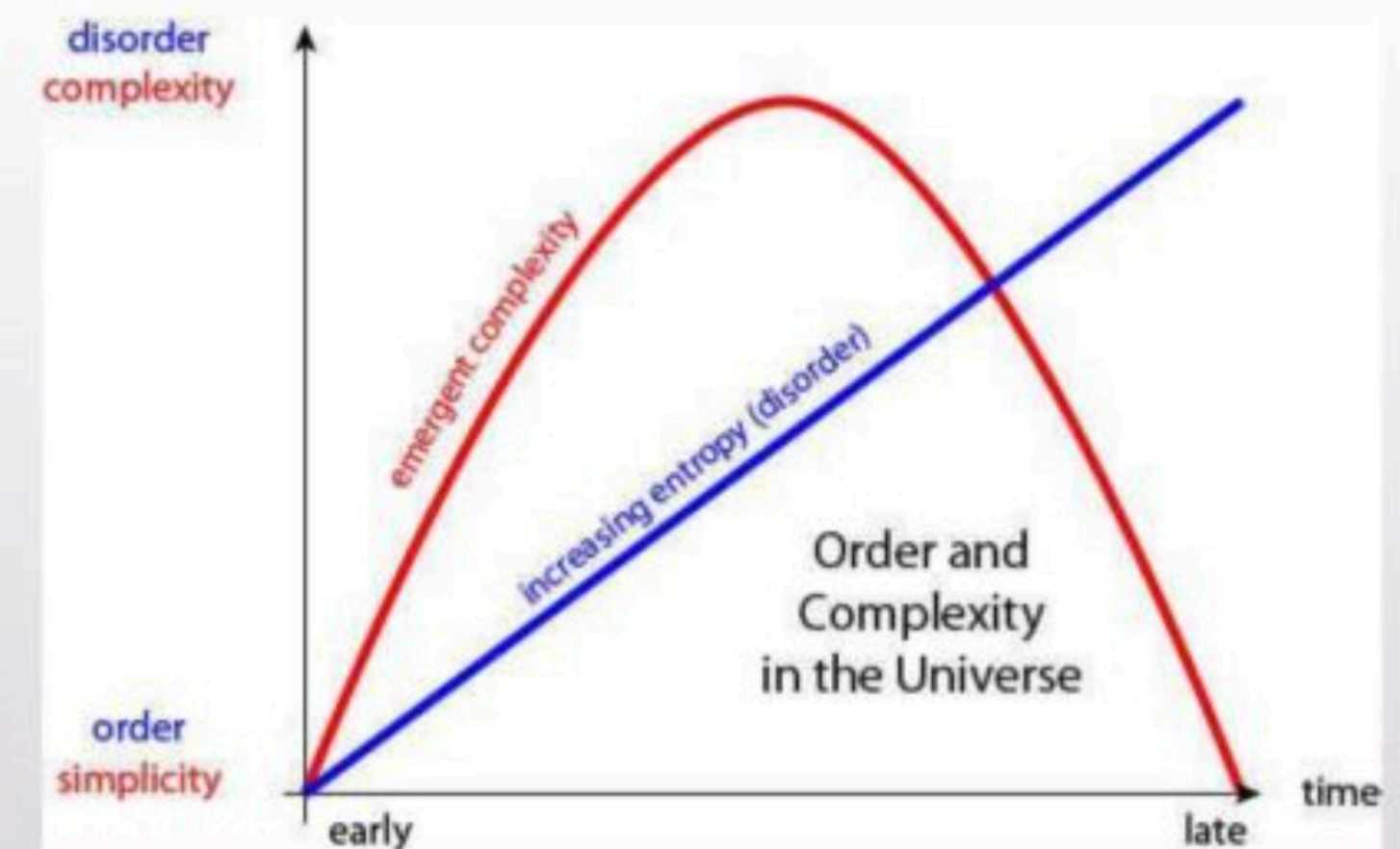

Is there a law of thermodynamics governing the evolution of complexity?

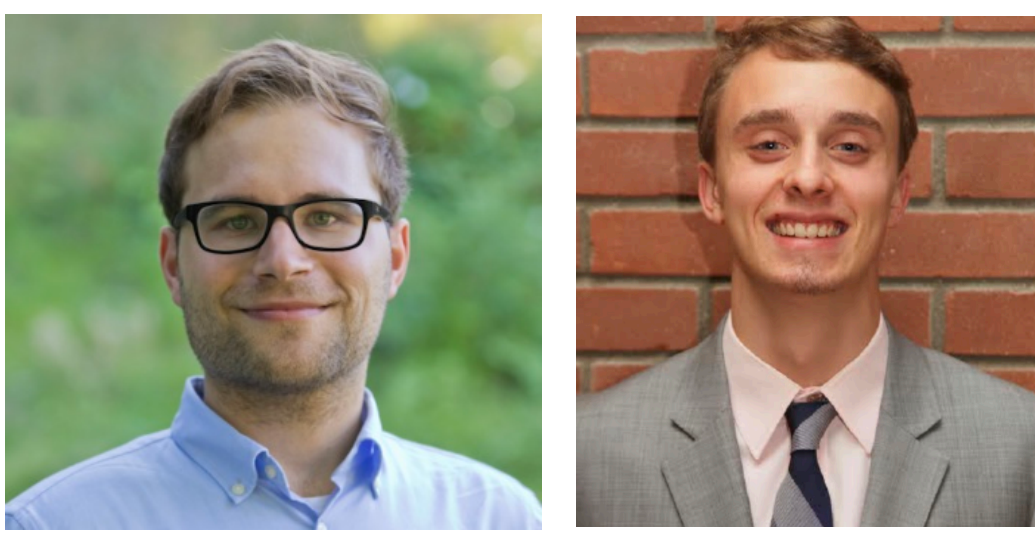

String Breaking and Hadronization

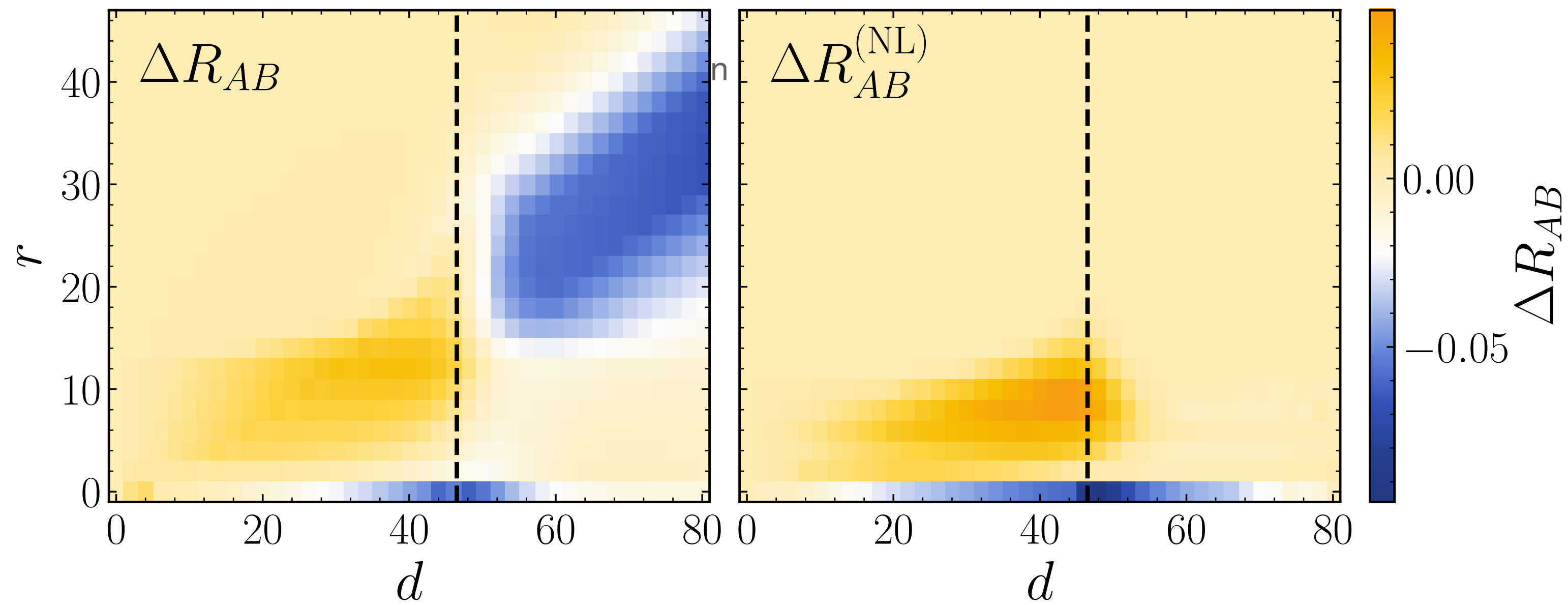
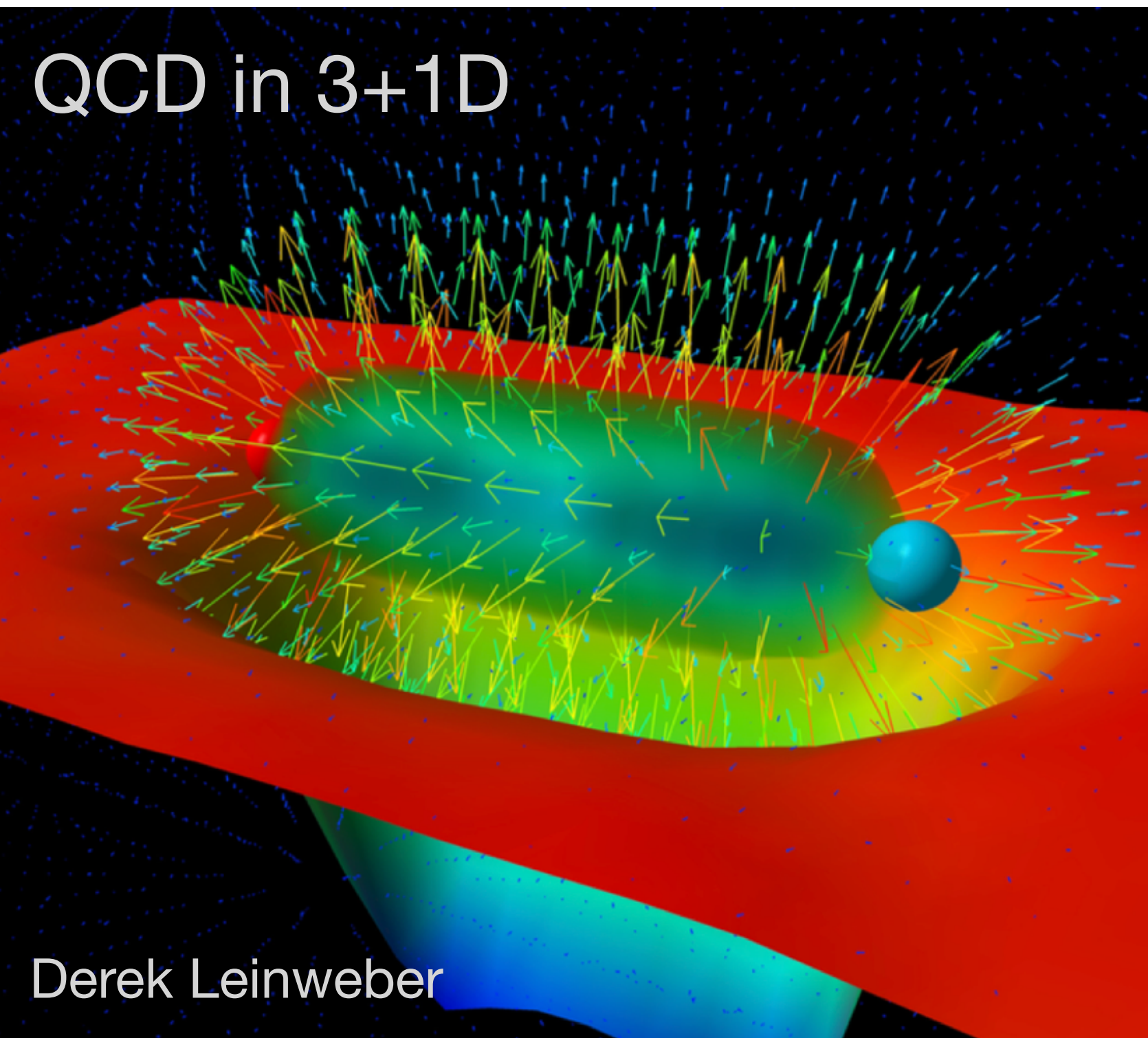
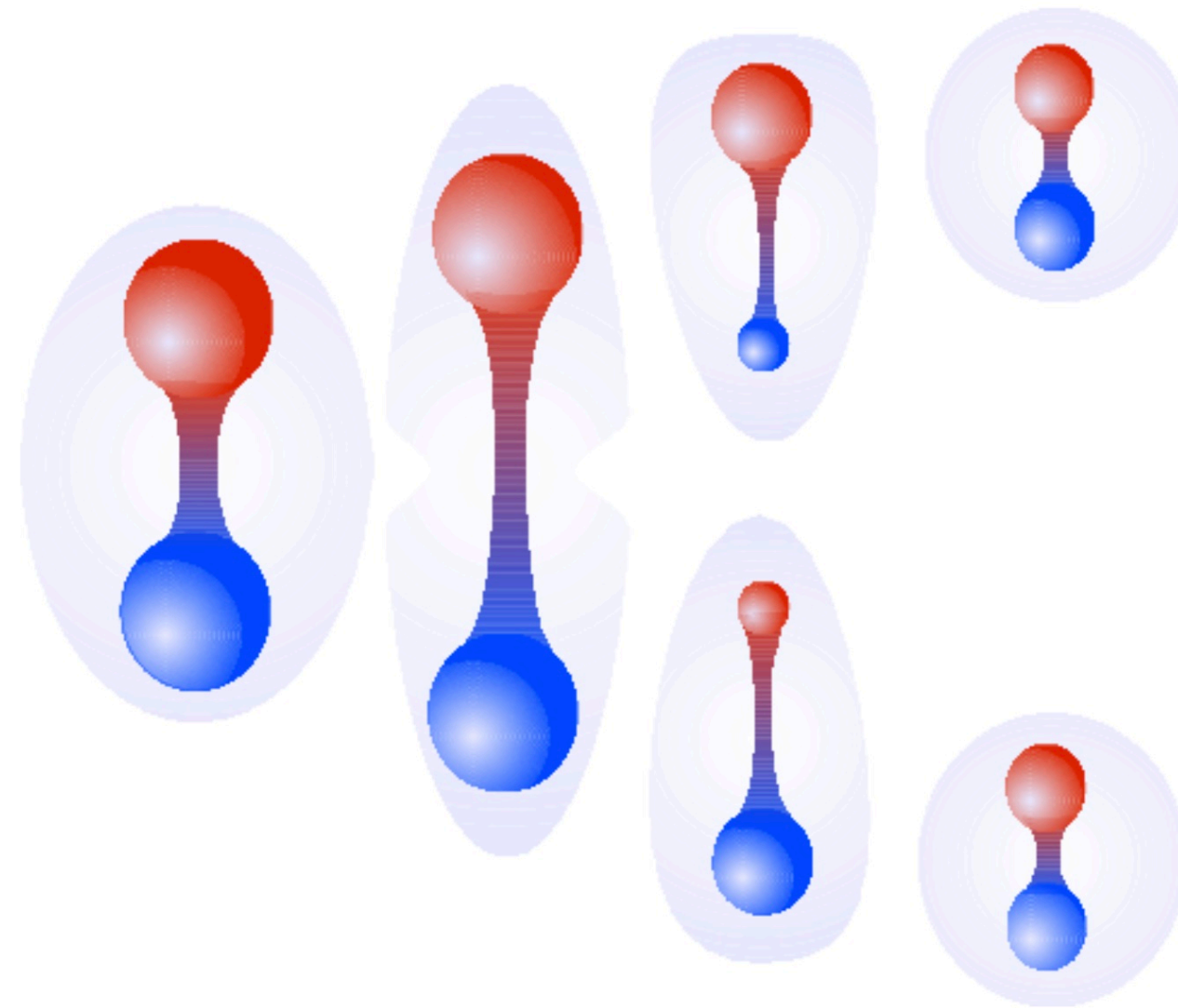

Robustness of Magic

How far away is the nearest classically efficient state



Quantum Complexity in Neutrinos - Qutrits

Quantum magic and computational complexity in the neutrino sector

Ivan Chernyshev ^{1,*}, Caroline E. P. Robin ^{2,3,†}, and Martin J. Savage ^{1,‡,§}

Show more

Phys. Rev. Research 7, 023228 – Published 4 June, 2025

DOI: <https://doi.org/10.1103/PhysRevResearch.7.023228>

For the two-qutrit system, explicit calculation gives a maximum value of magic in a tensor-product state of $M_2 = 2$ (consistent with $2\times$ the maximum value for a single three-flavor neutrino), while entangled states can support a maximum value of $M_2 = 2.23379$.

$$\hat{\Sigma}_i \in \{\hat{I}, \hat{X}, \hat{Z}, \hat{X}^2, \omega \hat{X} \hat{Z}, \hat{Z}^2, \omega^2 \hat{X} \hat{Z}^2, \hat{X}^2 \hat{Z}, \hat{X}^2 \hat{Z}^2\}$$

$$\hat{X}|j\rangle = |j+1\rangle, \quad \hat{Z}|j\rangle = \omega^j|j\rangle, \quad \omega = e^{i2\pi/3}$$

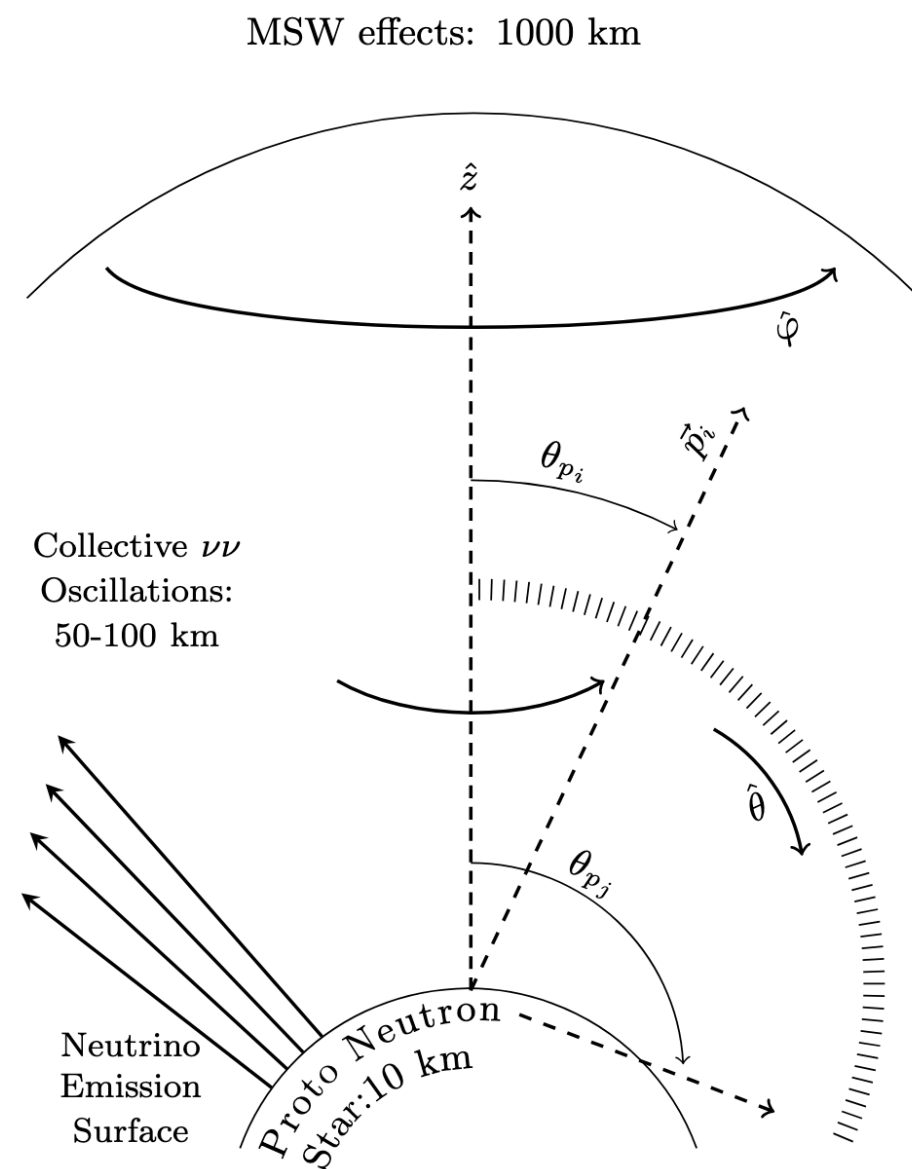
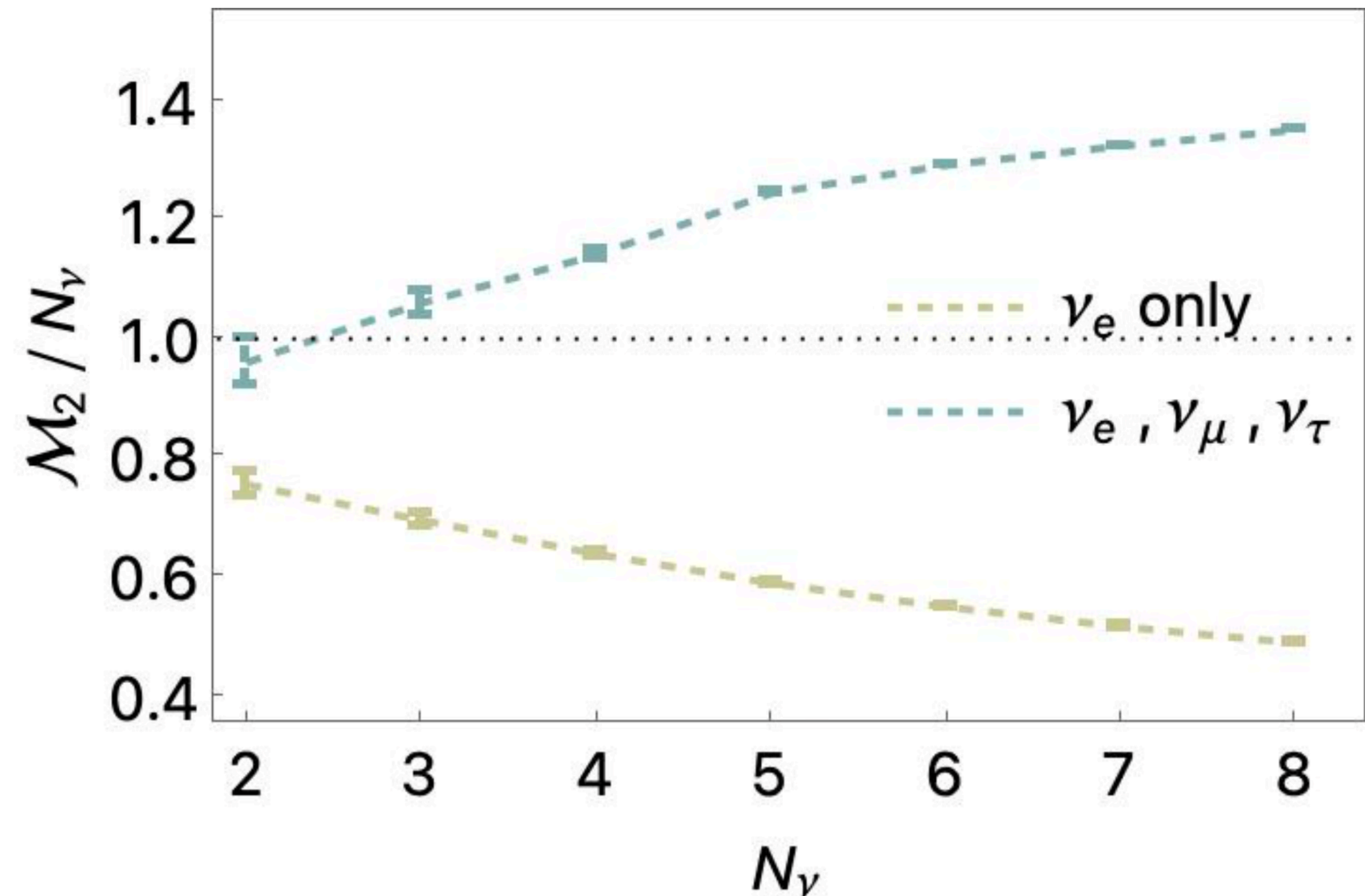

Figure created by Ramya Bhaskar





1-Plaquette of SU(2) Yang-Mills Magic to Guide Truncations (?)

Marc Illa + MJS -

$$\hat{H} = \frac{g^2}{2} \sum_{\mathbf{a}, \text{links}} |\mathbf{E}^{\mathbf{a}}|^2 + \frac{1}{2g^2} \left(4 - \hat{\square} - \hat{\square}^\dagger \right) \quad H_{j,j'} = \frac{1}{2} g^2 j(j+1) \delta_{j,j'} + \frac{1}{g^2} (2\delta_{j,j'} - \delta_{j+1,j'} - \delta_{j-1,j'})$$

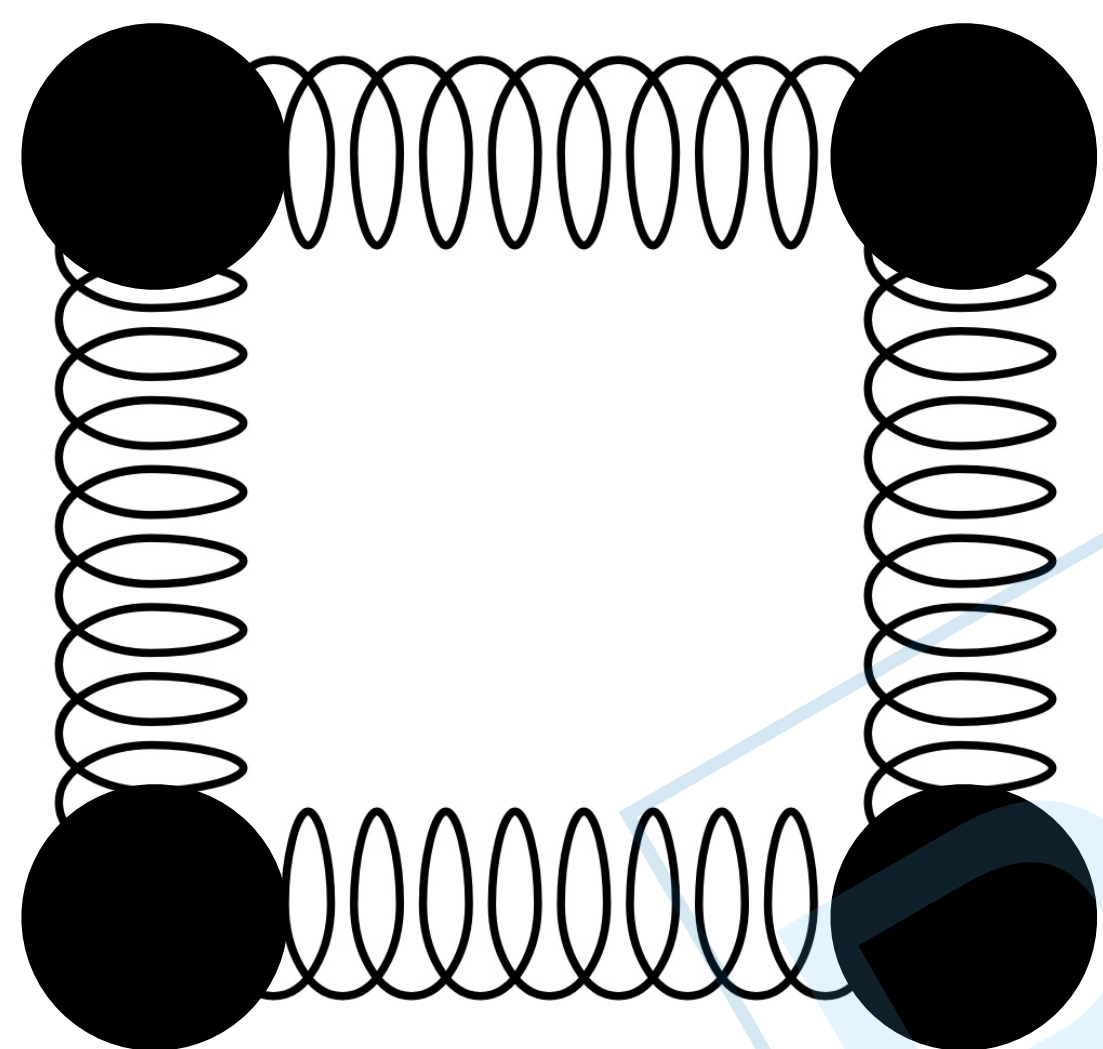

qudit



$j_{\text{Max}} = 1/2, 1, 3/2, 2, \dots$

M_2

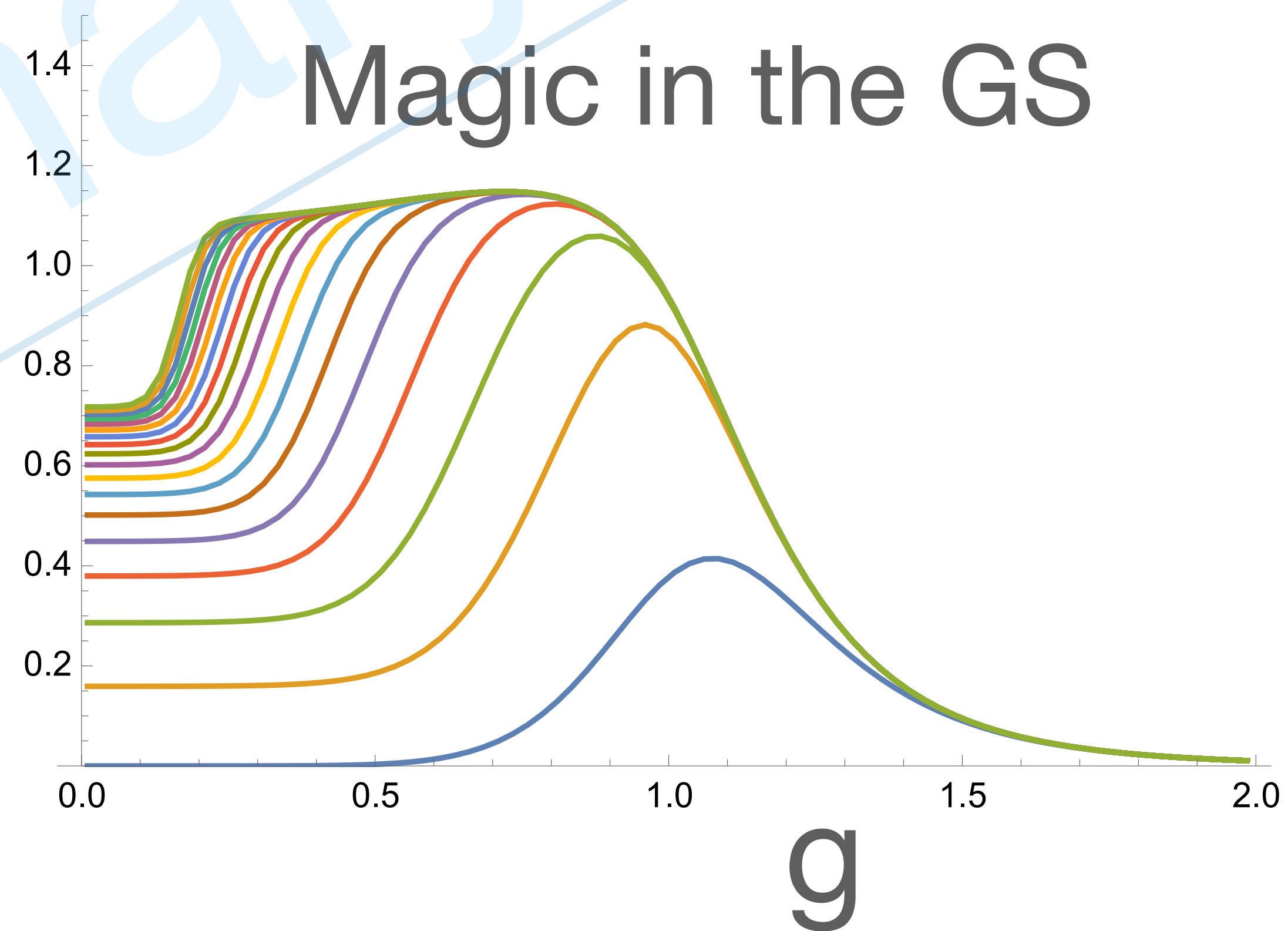

Anti-Flatness

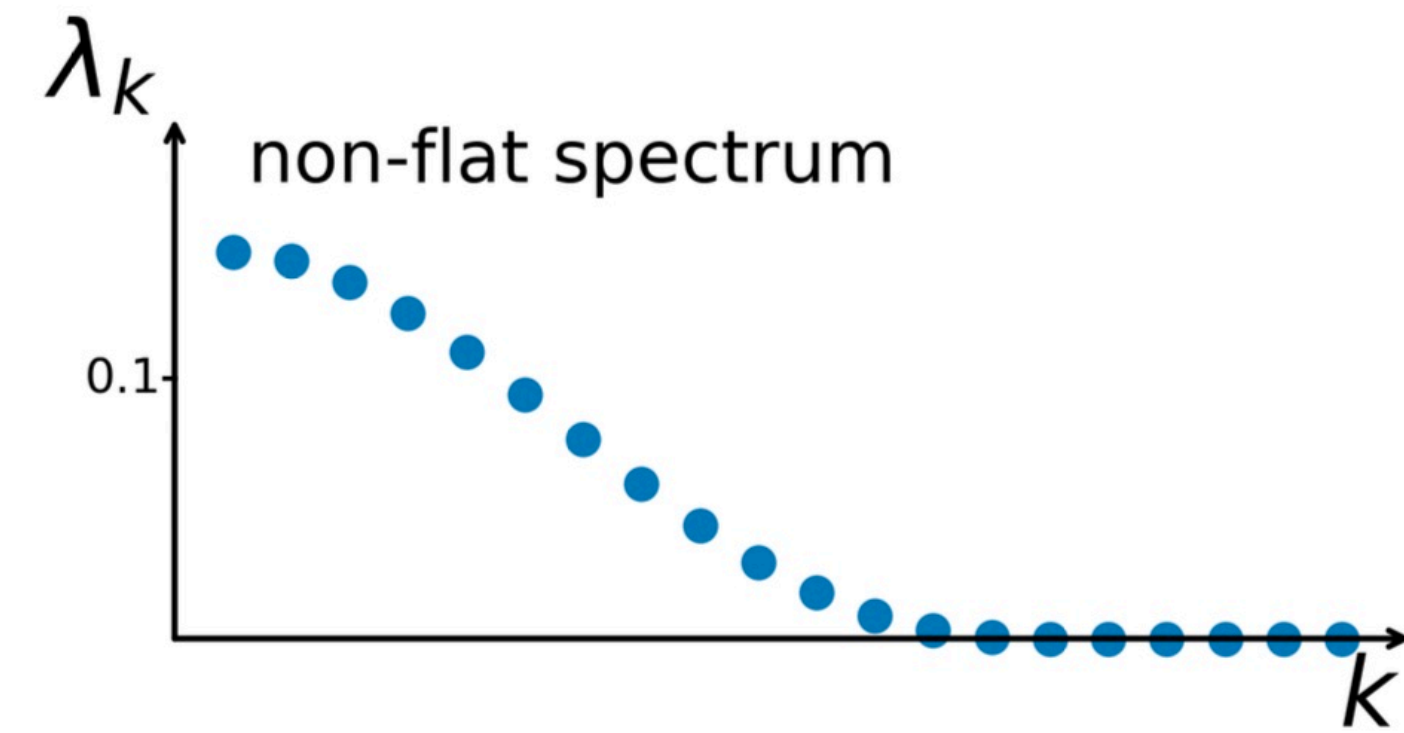
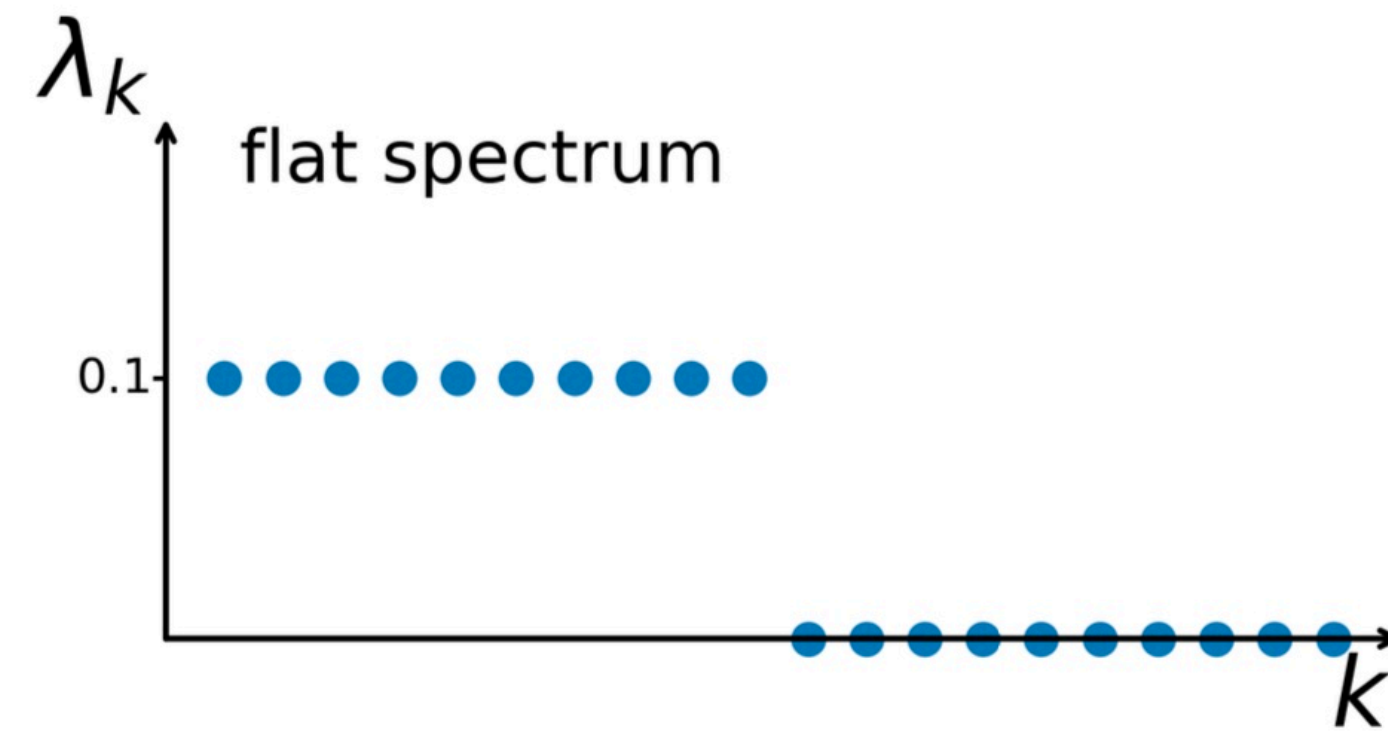
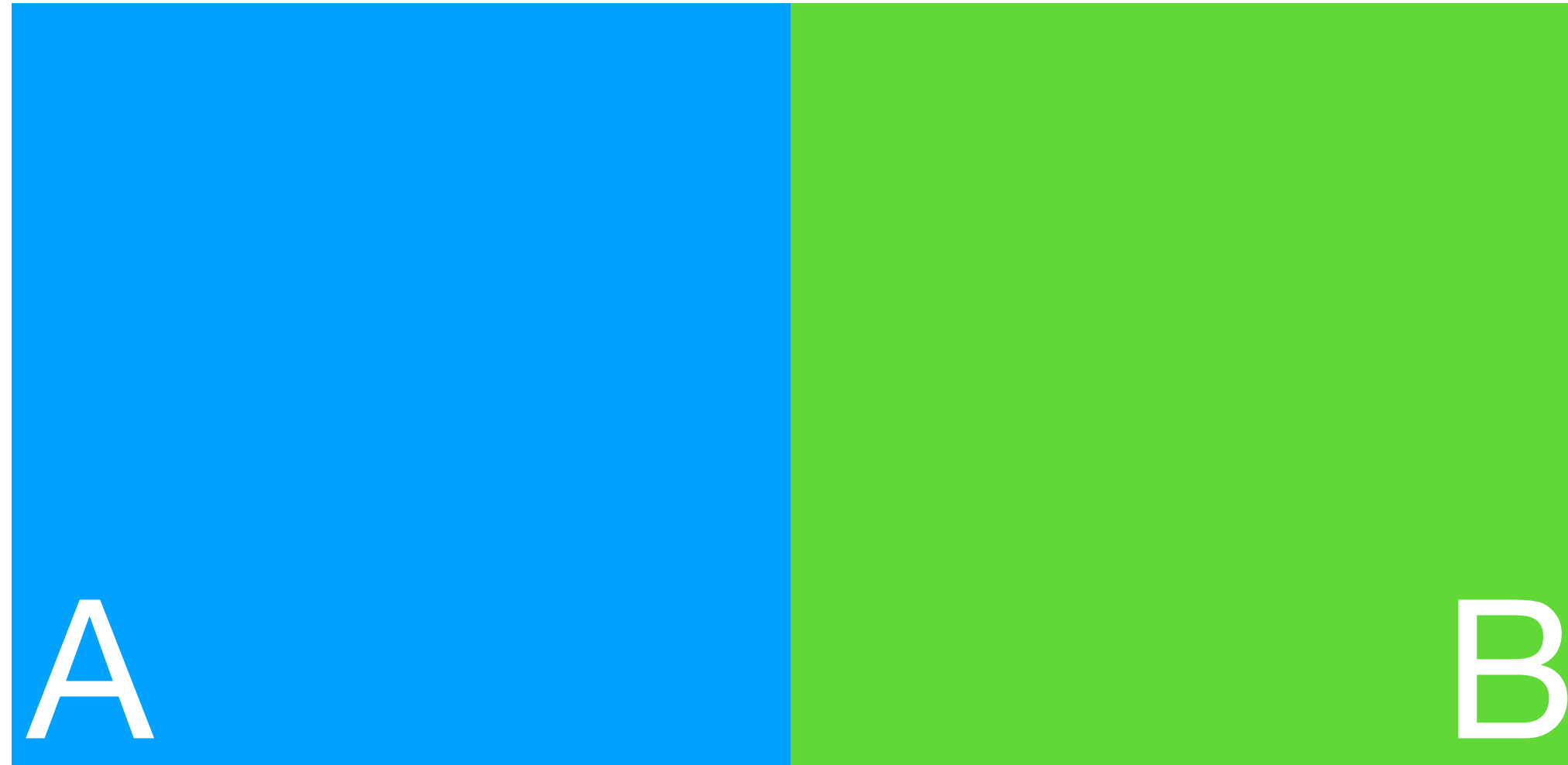

$$\mathcal{F}_A(|\psi\rangle_{AB}) = \langle \rho_A^2 \rangle - \langle \rho_A \rangle^2 = \text{Tr}(\rho_A^3) - (\text{Tr} \rho_A^2)^2$$

$$4 \mathcal{F}_A(|\psi\rangle_{AB}) \leq \mathcal{M}_{\text{lin}}^{2, NL}(|\psi\rangle_{AB})$$

Renormalization Group Flow of Complexity

Gaussian Smearing

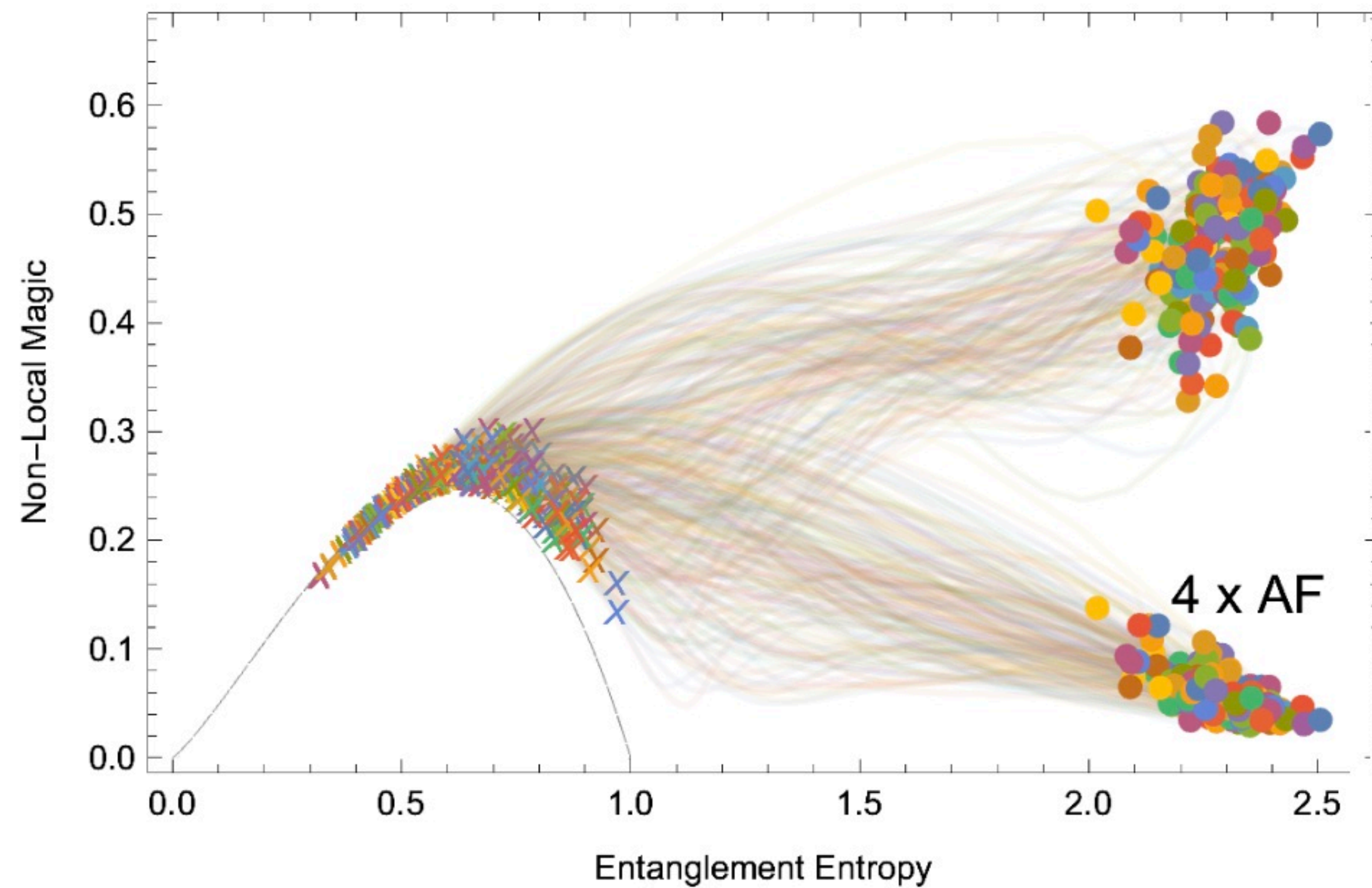

Sequency Truncation

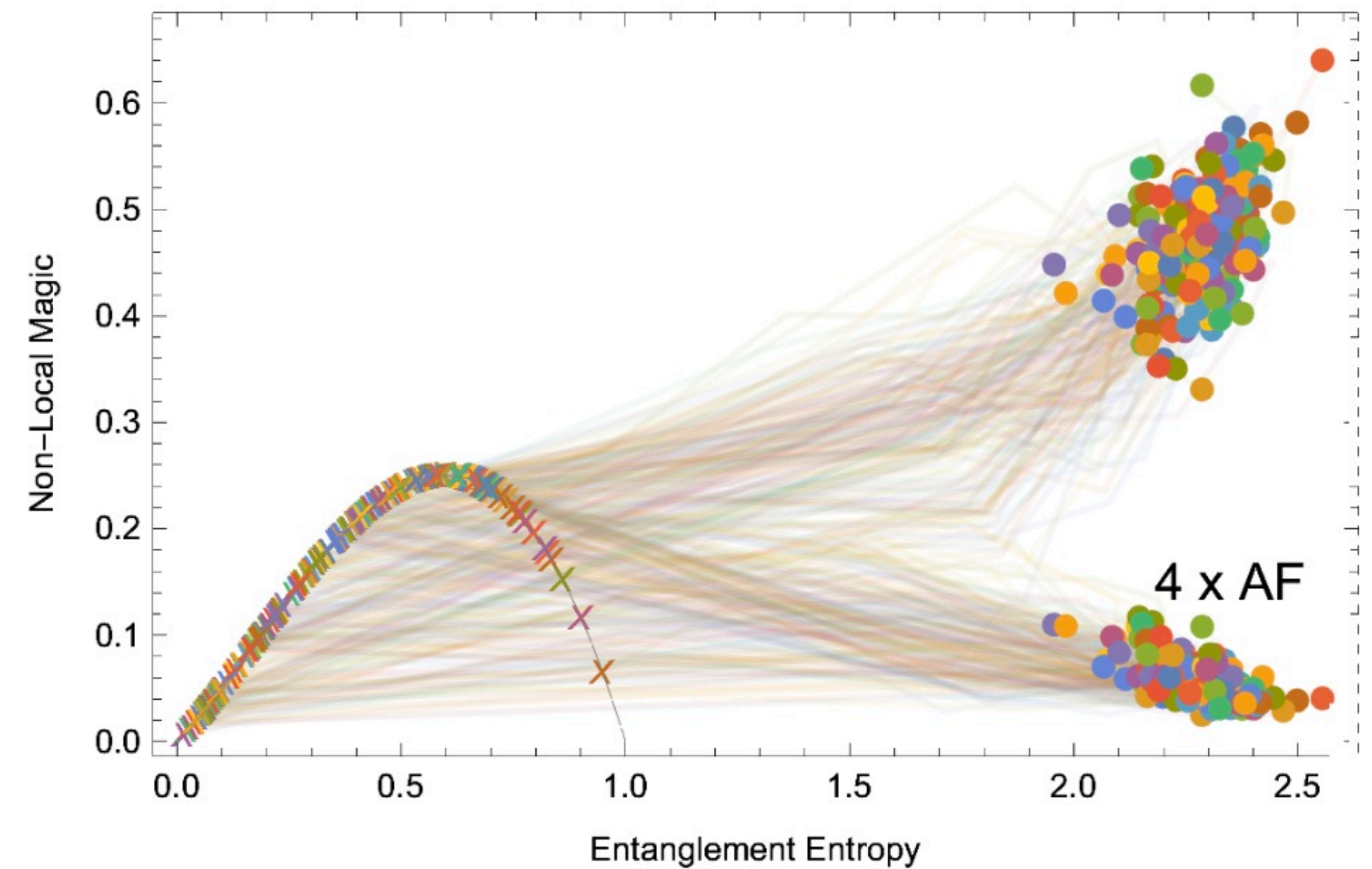

6-qubits from Haar measure

Entanglement Suppression and Emergent Symmetries of Strong Interactions

Silas R. Beane¹, David B. Kaplan², Natalie Klco^{1,2}, and Martin J. Savage²

Show more

Phys. Rev. Lett. **122**, 102001 – Published 14 March, 2019

Exp

Quantum complexity fluctuations from nuclear and hypernuclear forces

Caroline E. P. Robin^{1,2,*} and Martin J. Savage^{3,†,‡}

Show more

Phys. Rev. C **112**, 044004 – Published 17 October, 2025

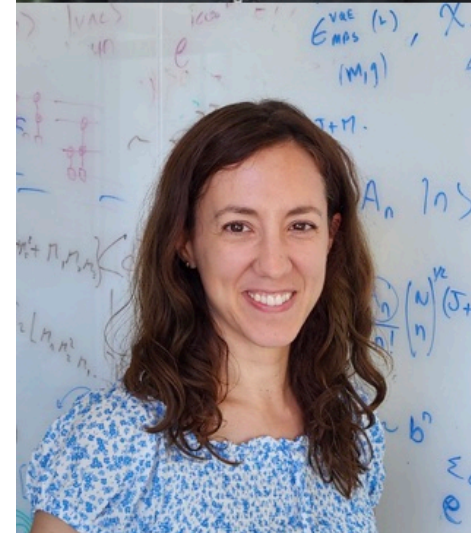
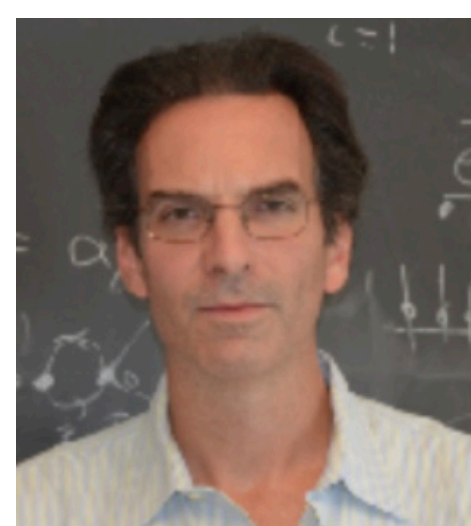

Entanglement and Magic Power of the S-Matrix : Low-energy Baryon-Baryon

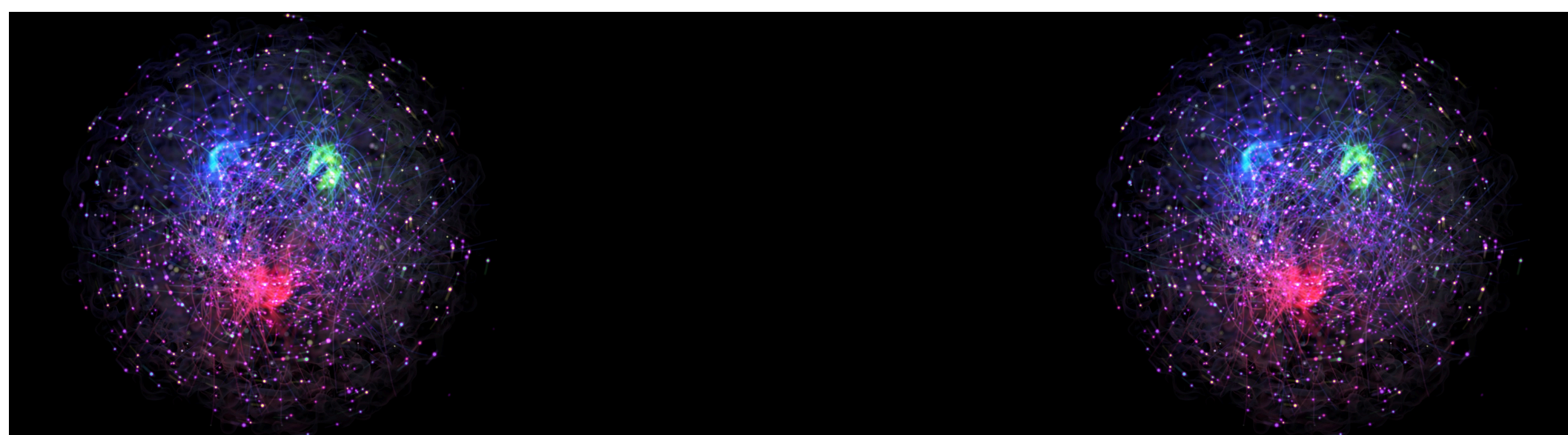
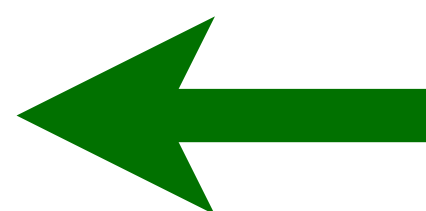
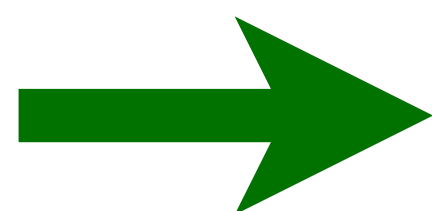

S-wave, elastic, coupled spin channels

$$\hat{\mathbf{S}}_{\sigma} = \frac{1}{4} (3e^{i2\delta_3} + e^{i2\delta_1}) \hat{\mathbf{1}} + \frac{1}{4} (e^{i2\delta_3} - e^{i2\delta_1}) \hat{\boldsymbol{\sigma}} \cdot \hat{\boldsymbol{\sigma}}$$

$$\overline{\mathcal{E}}(\hat{\mathbf{S}}) \equiv \frac{1}{\mathcal{N}_{ss}^{TP}} \sum_{i=1}^{\mathcal{N}_{ss}^{TP}} \mathcal{E} \left(\rho_i^{(1)}(\hat{\mathbf{S}}) \right)$$

$$\overline{\overline{\mathcal{M}}_{\text{lin}}^{(NL)}}(\hat{\mathbf{S}}) \equiv \frac{1}{36} \sum_{i=1}^{36} \mathcal{M}_{\text{lin}}^{(NL)} \left(\hat{\mathbf{S}} | \psi_i \rangle \right)$$

$$\overline{\mathcal{M}}(\hat{\mathbf{S}}) = \frac{3}{20} \left(3 + \cos(4 \Delta\delta) \right) \sin^2(2 \Delta\delta) ,$$

$$\overline{\mathcal{E}}(\hat{\mathbf{S}}) = \frac{1}{6} \sin^2(2 \Delta\delta) ,$$

Vanishing entanglement and magic power:
 2-flavor = SU(4) spin-flavor emergent
 3-flavor = SU(16) spin-flavor emergent
 Conformal symmetries

Entanglement Suppression and Emergent Symmetries of Strong Interactions

Silas R. Beane¹, David B. Kaplan², Natalie Klco^{1,2}, and Martin J. Savage²

Show more

Phys. Rev. Lett. **122**, 102001 – Published 14 March, 2019

Exp

Quantum complexity fluctuations from nuclear and hypernuclear forces

Caroline E. P. Robin^{1,2,*} and Martin J. Savage^{3,†,‡}

Show more

Phys. Rev. C **112**, 044004 – Published 17 October, 2025

Entanglement and Magic Power of the S-Matrix : Low-energy Baryon-Baryon

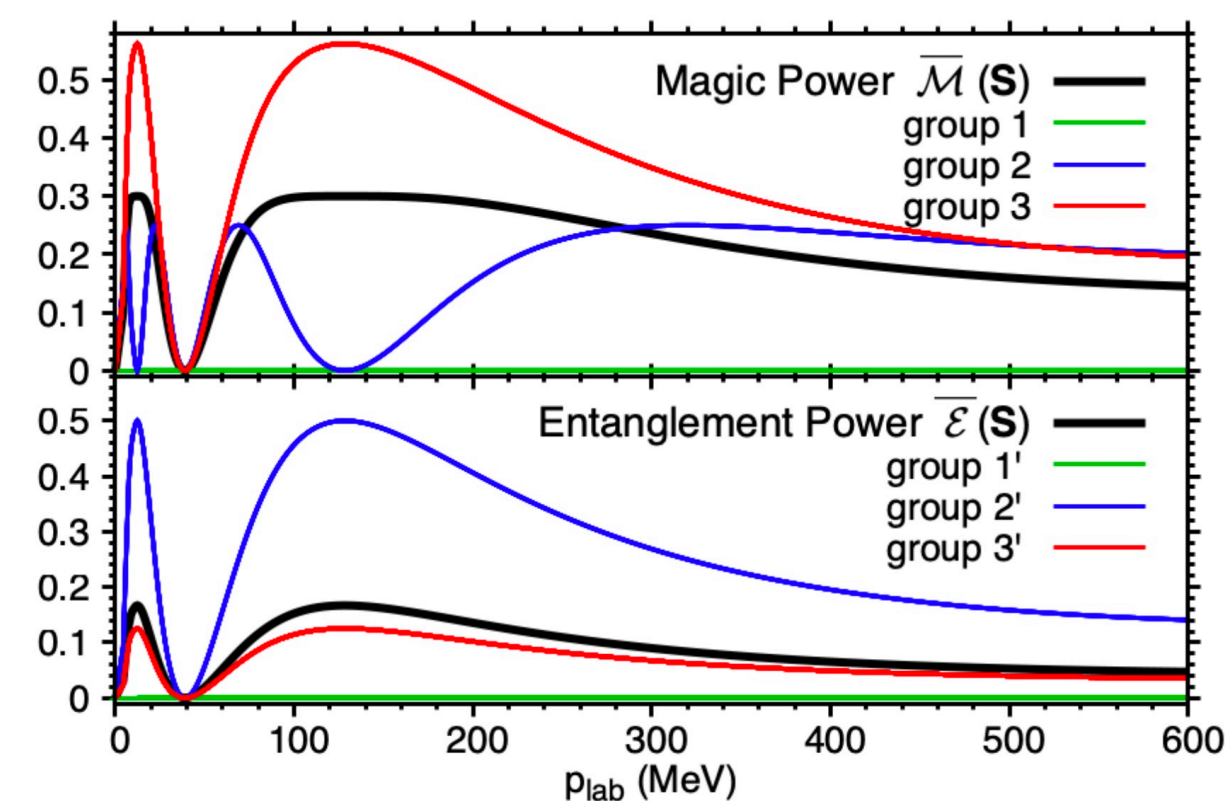
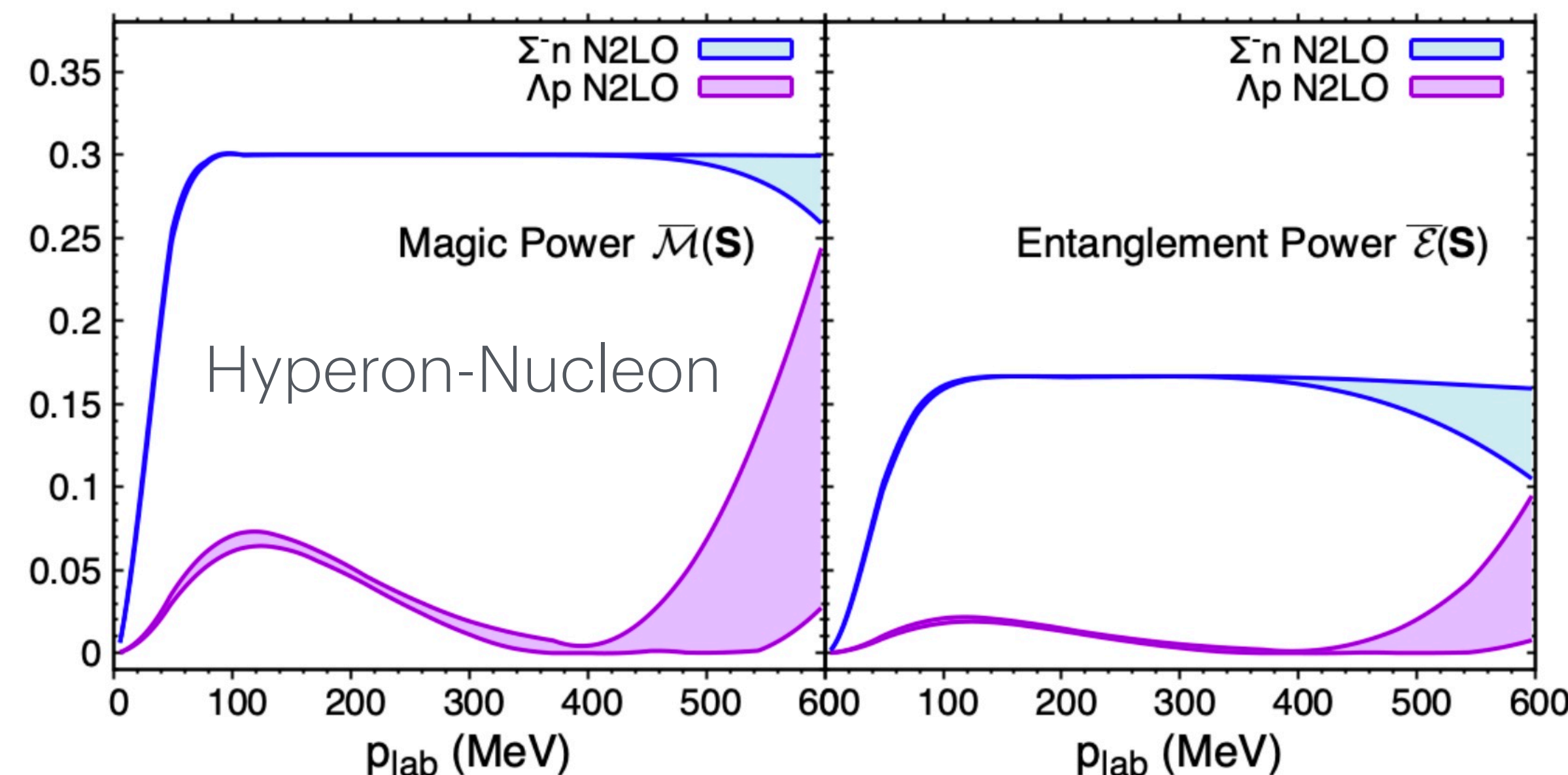
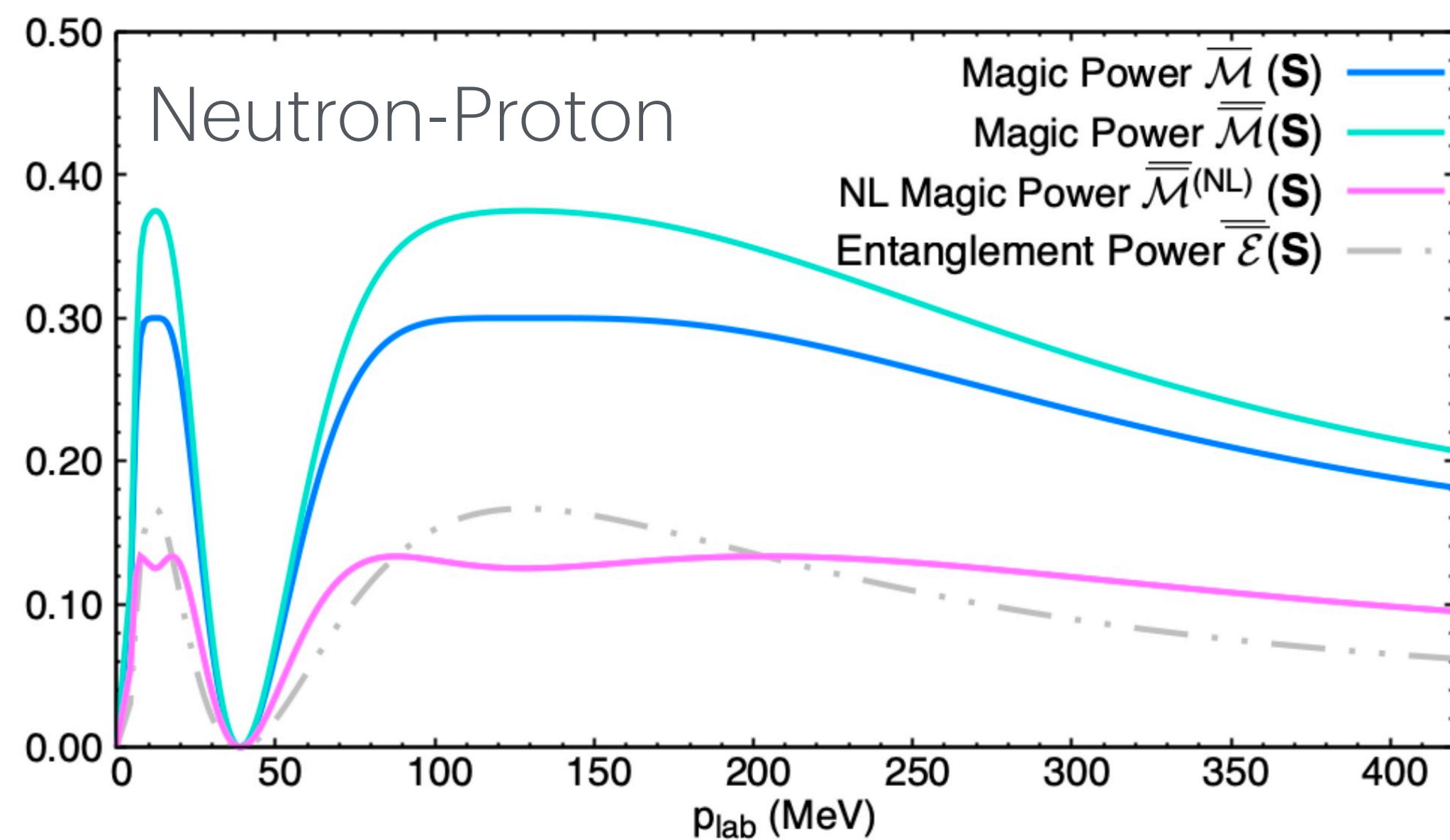
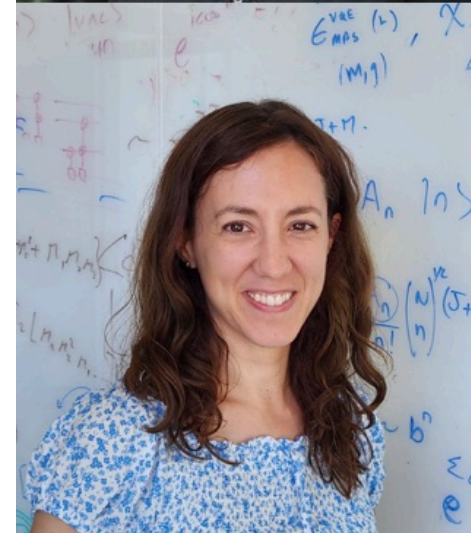
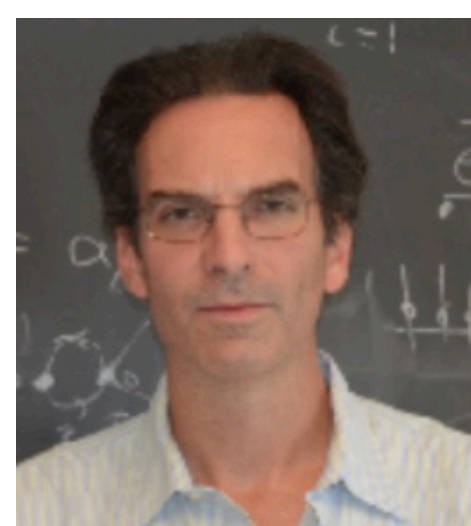

Baryon-baryon interactions and spin-flavor symmetry from lattice quantum chromodynamics

Michael L. Wagman^{1,2}, Frank Winter³, Emmanuel Chang², Zohreh Davoudi⁴, William Detmold⁴, Kostas Orginos^{5,3}, Martin J. Savage^{1,2}, and Phiala E. Shanahan⁴ (NPLQCD Collaboration)

Show more

Phys. Rev. D 96, 114510 – Published 28 December, 2017

Lattice QCD Results and Symmetries

Unnatural case

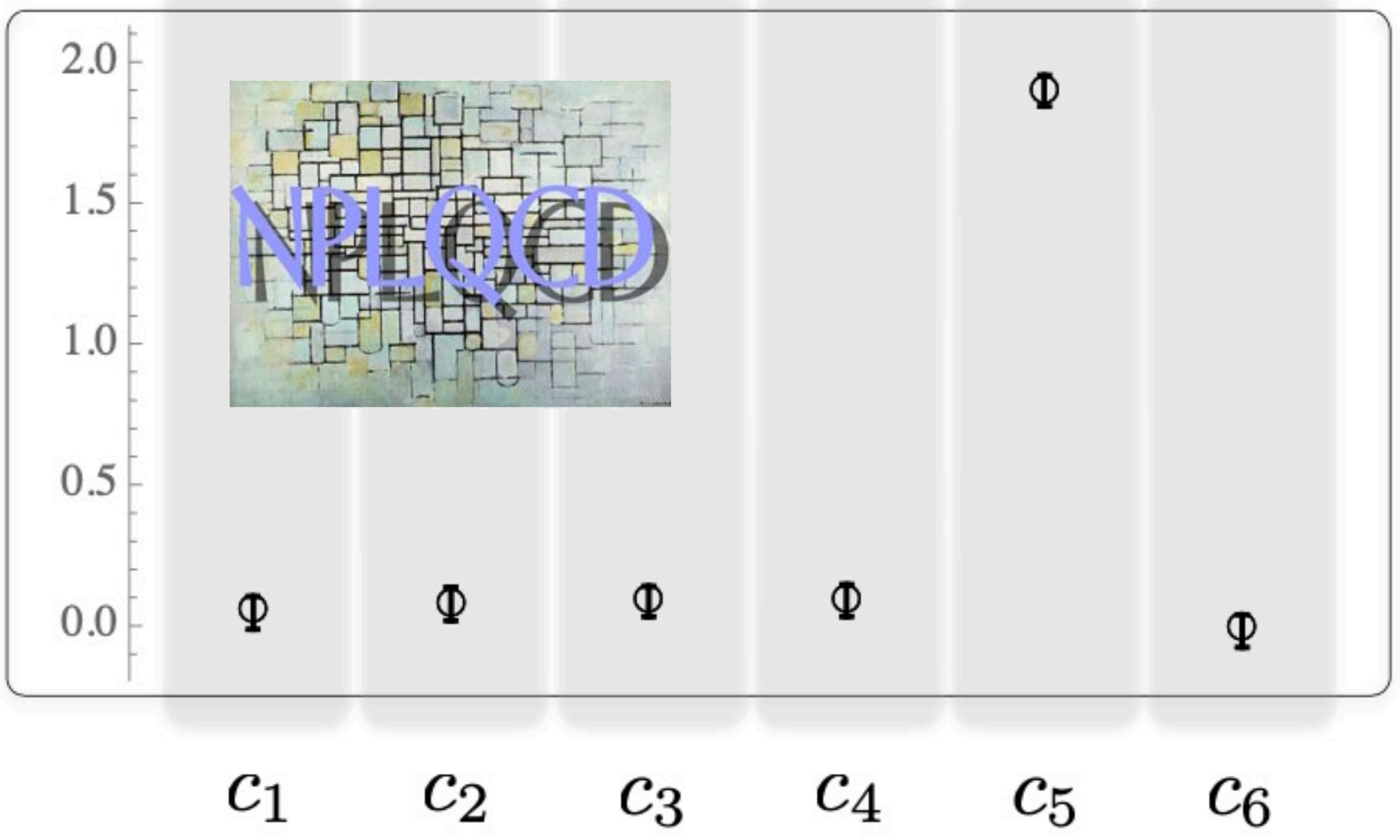

~800 MeV pion mass

Results consistent with SU(6) and SU(16)

Spin versus Magic: Lessons from Gluon and Graviton Scattering

John Gargalionis^{*1}, Nathan Moynihan^{†2}, Sokratis Trifinopoulos^{‡3,4}, Ewan N. V. Wallace^{§1},
Chris D. White^{¶2}, and Martin J. White^{||1}

arXiv:2508.14967v1 [hep-th] 20 Aug 2025

Total Magic Power of Gluons Perturbation Theory

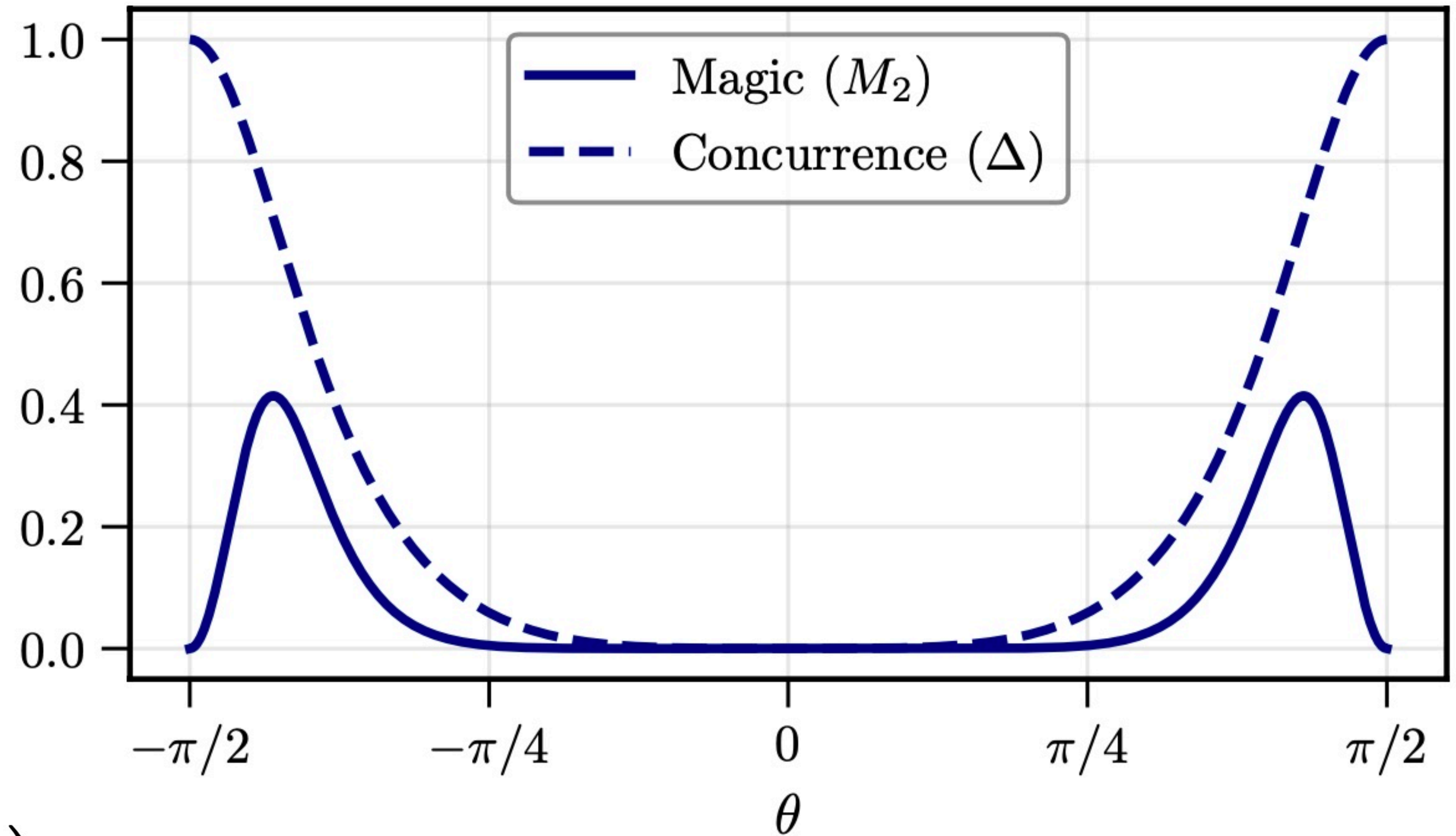
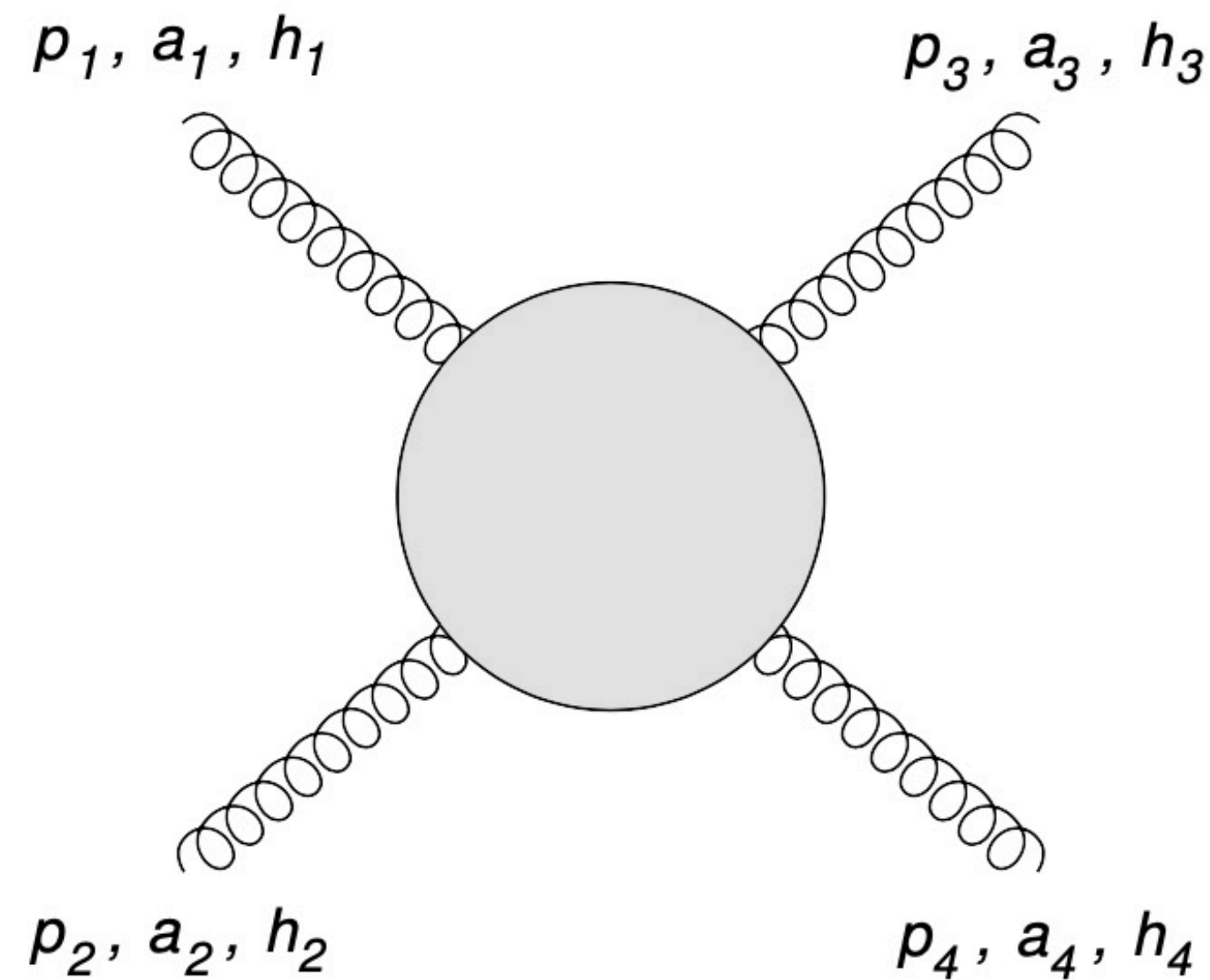

$$M_2(|\psi\rangle_{RL}) = -\log\left(\frac{t^{16} + 14t^8u^8 + u^{16}}{(t^4 + u^4)^4}\right)$$

Non-local nonstabiliserness in Gluon and Graviton Scattering

Non-Local Magic Power of Gluons Perturbation Theory

John Gargalionis^{*1}, Nathan Moynihan^{†2}, Michael L. Reichenberg Ashby^{‡2}, Ewan N. V. Wallace^{§1}, Chris D. White^{¶2}, and Martin J. White^{||1}

arXiv:2603.04148v1 [hep-th] 4 Mar 2026

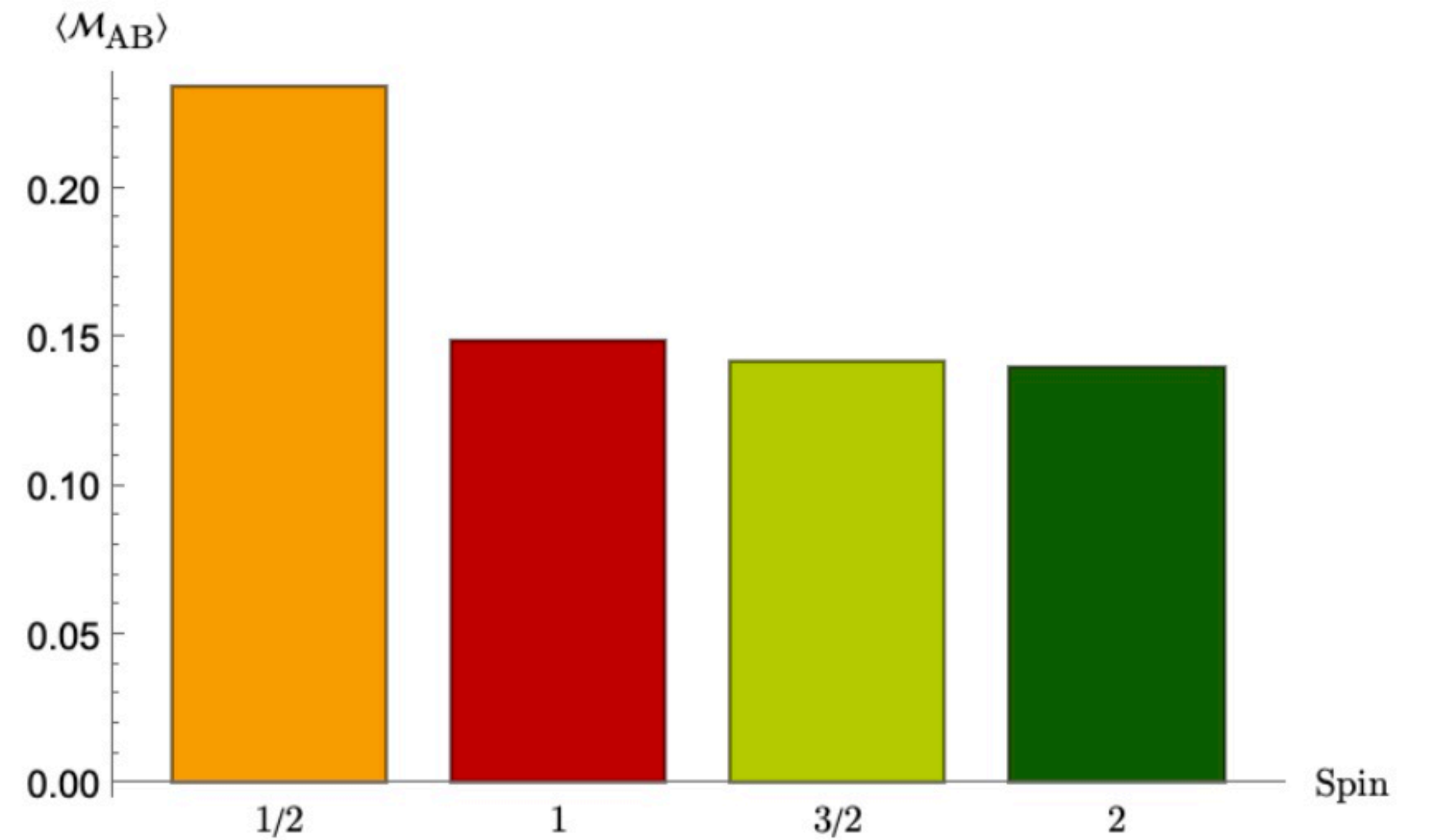
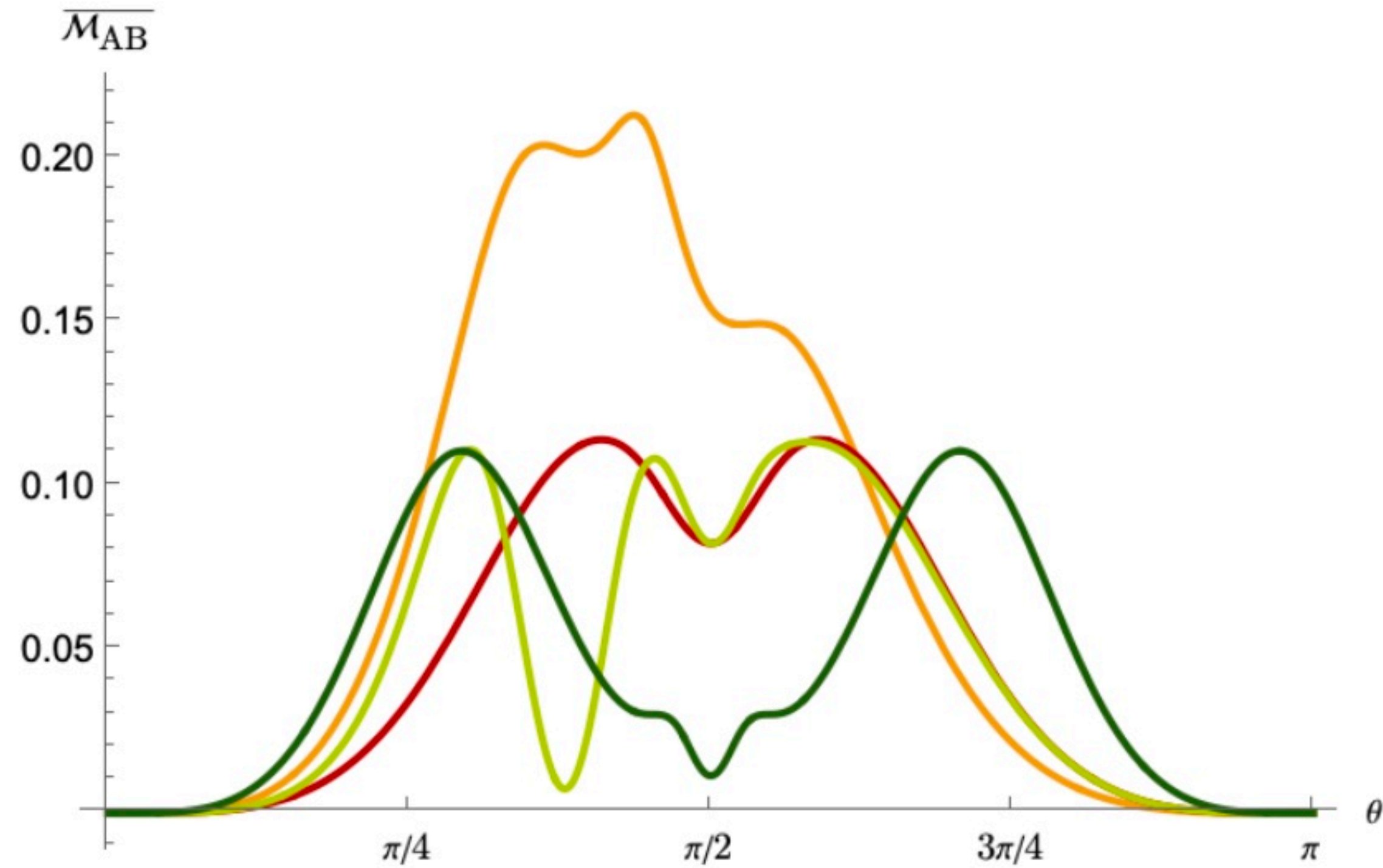

— Gluino — Gluon — Gravitino — Graviton

Top—Anti-Top Production at LHC

C.D. White, M.J. White, Magic states of top quarks. Phys. Rev. D **110**(11), 116016 (2024). <https://doi.org/10.1103/PhysRevD.110.116016>. ADP-24-10/T1249. [arXiv:2406.07321](https://arxiv.org/abs/2406.07321) [hep-ph]
Observation of magic states of top quark pairs produced in proton-proton collisions at $\sqrt{s} = 13$ TeV (CMS-PAS-TOP-25-001) (2025)

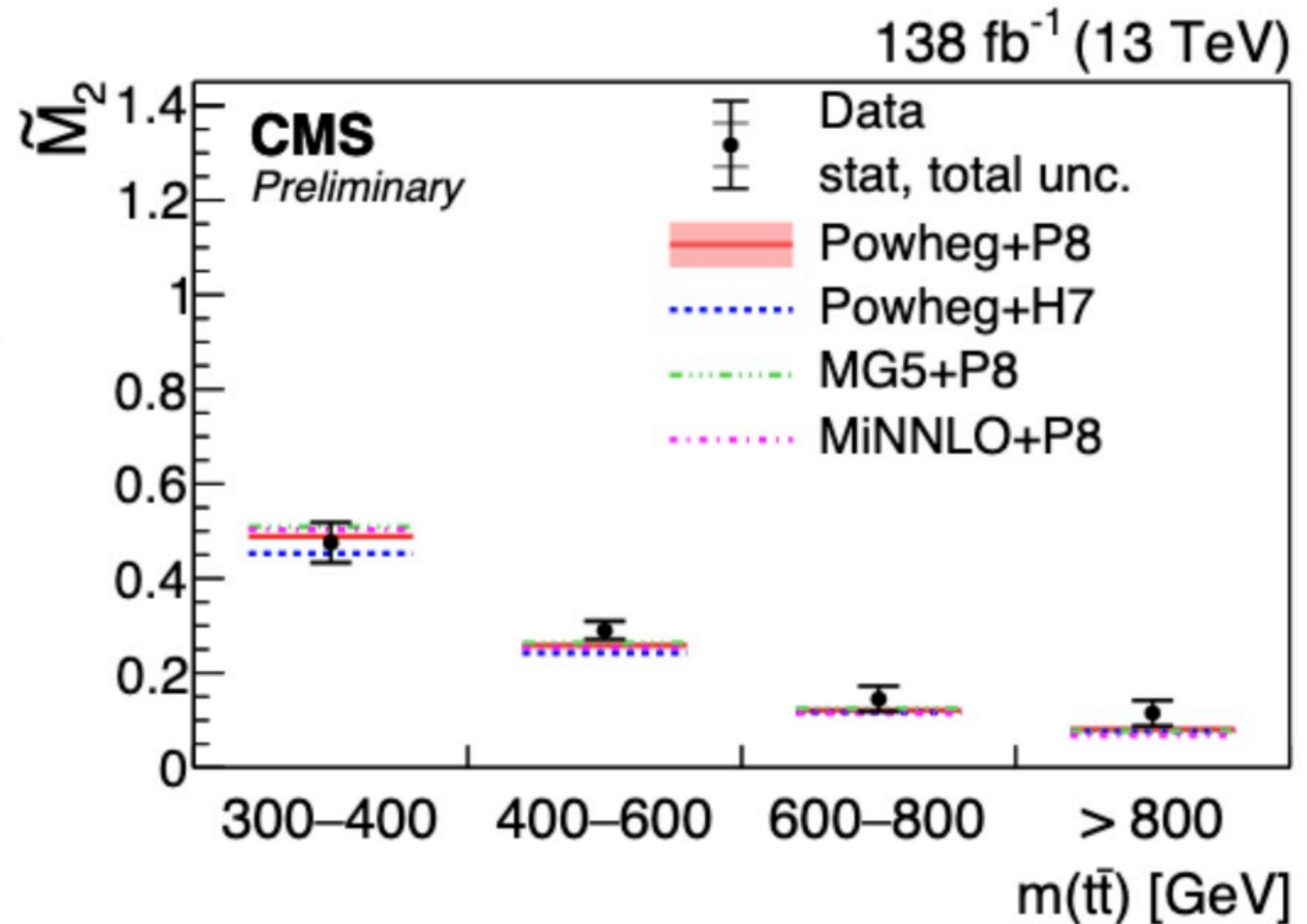

Part-2

Quantum Complexity

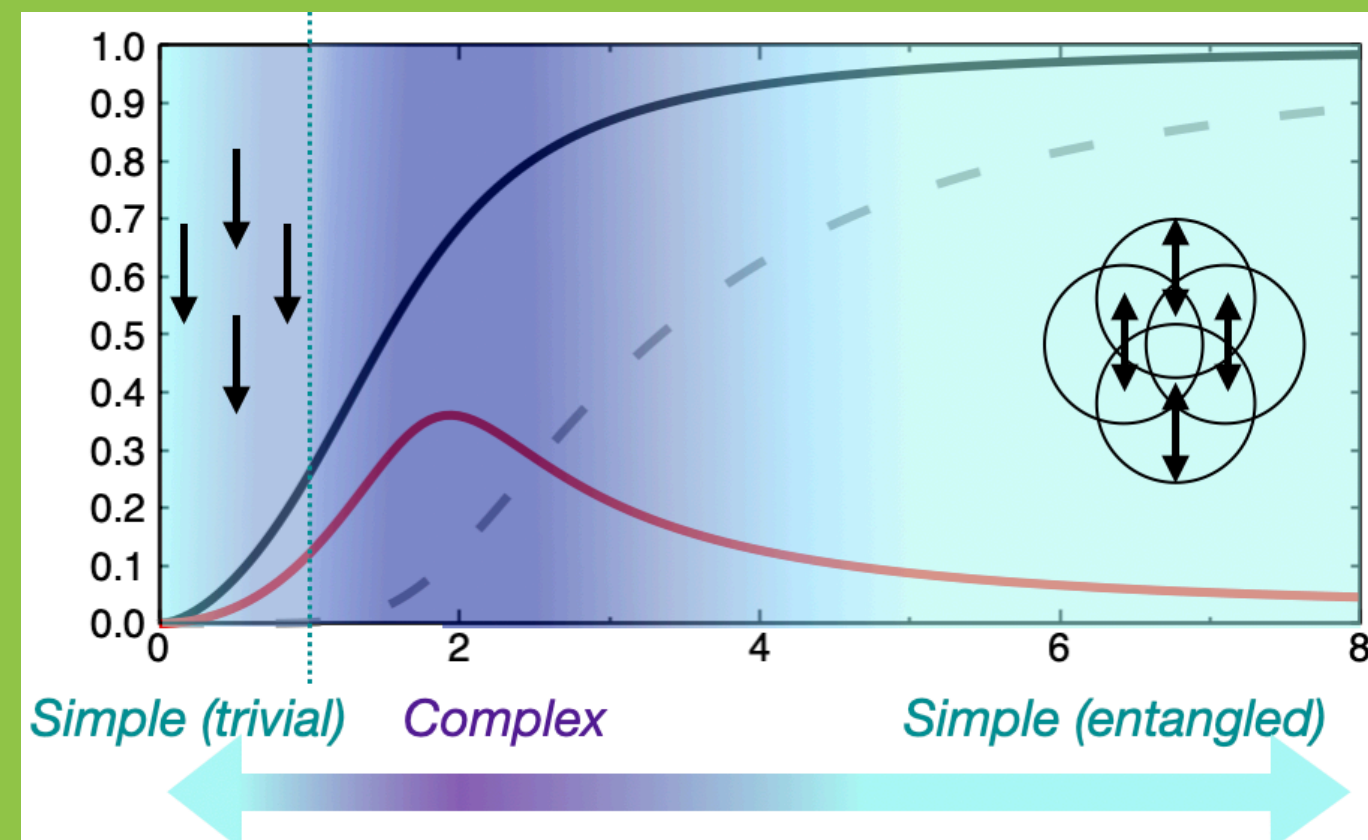

End of Day-1

From NISQ to Fault Tolerant - Sequency Hierarchies

Magic in a Gaussian: $\mathcal{M}_{\text{lin}} = 0.362007$

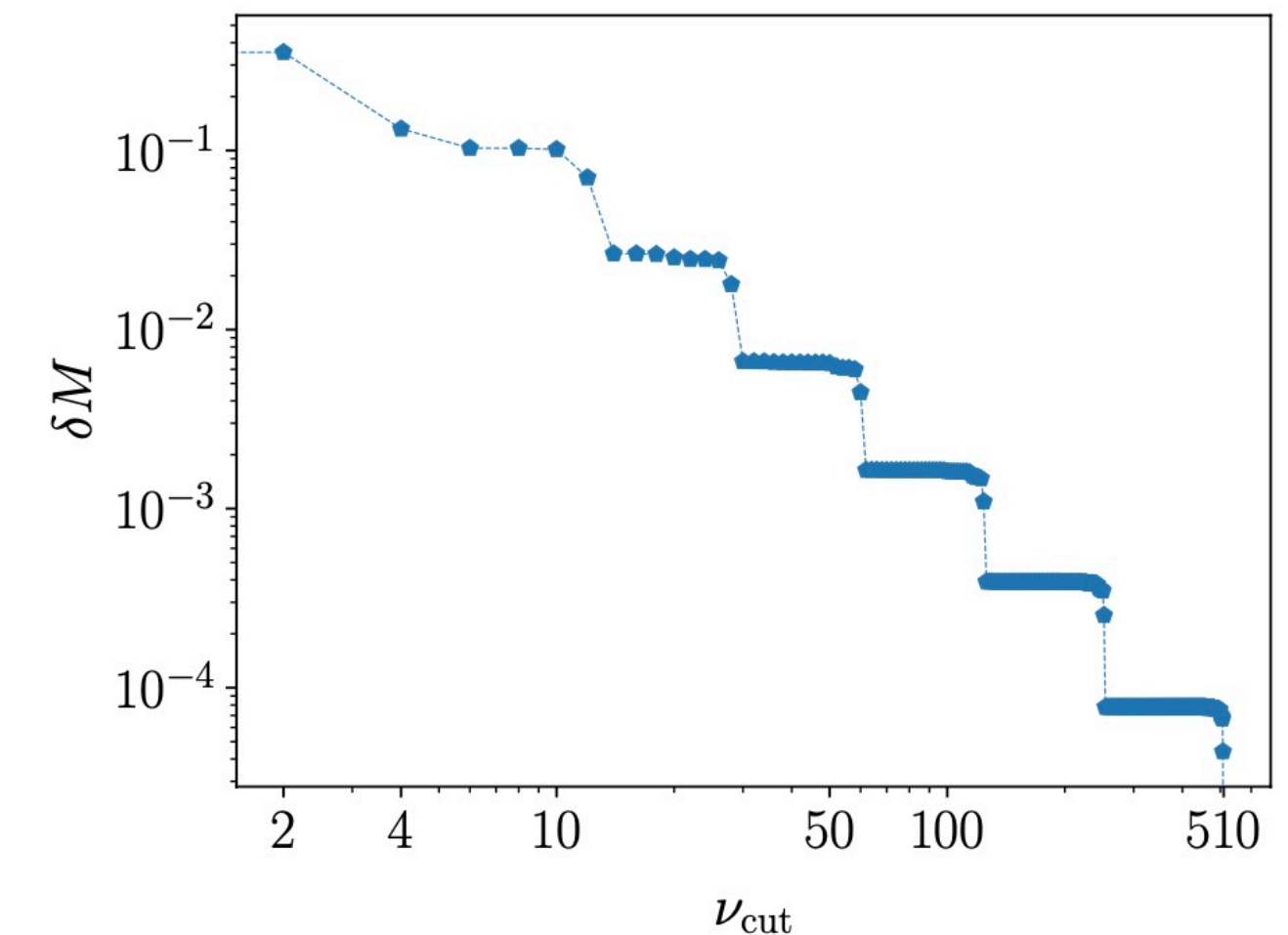
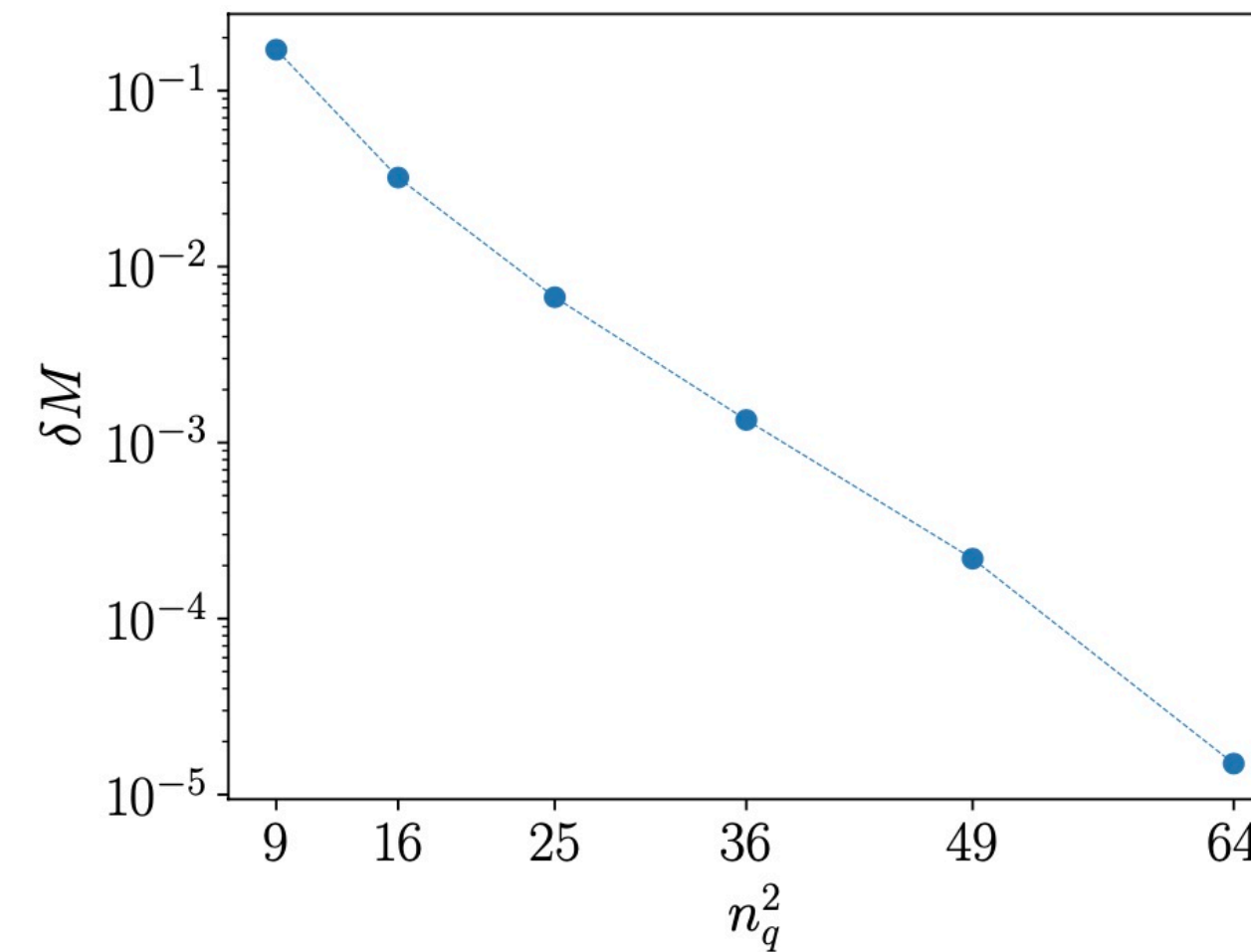
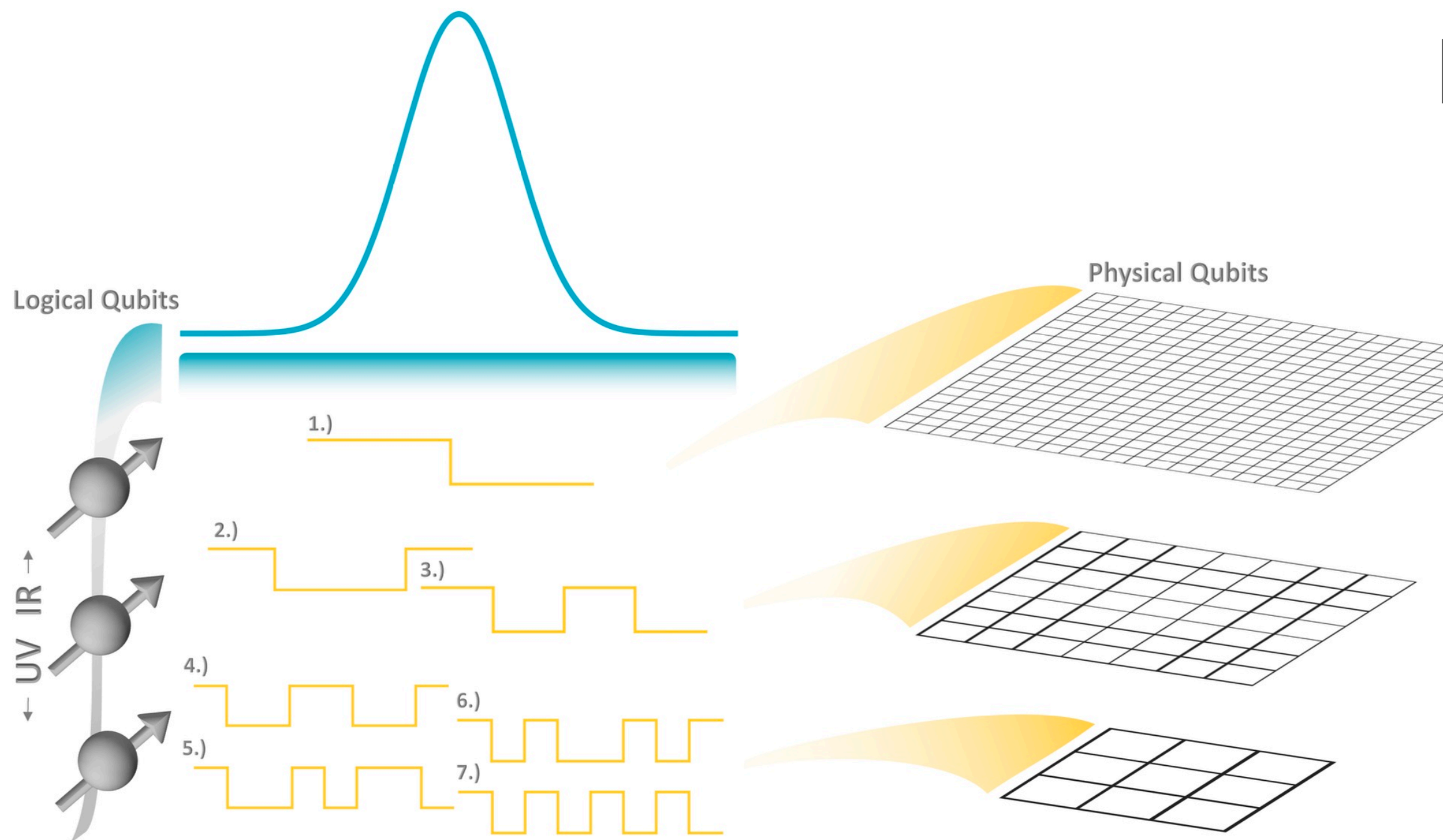

UV versus IR qubits



Hierarchical qubit maps and hierarchically implemented quantum error correction

Sequency Hierarchy Truncation (SeqHT) for Adiabatic State Preparation and Time Evolution in Quantum Simulations

N-Tangles

$$\tau_n(|\psi\rangle) = | \langle \psi | \tilde{\psi} \rangle |^2 \quad , \quad |\tilde{\psi}\rangle = \hat{Y}_{i_1} \hat{Y}_{i_2} \cdots \hat{Y}_{i_n} |\psi\rangle^*$$

$$|GHZ\rangle_4 = \frac{1}{\sqrt{2}} [|0000\rangle + |1111\rangle]$$

$$\hat{Y}^{\otimes 4} |GHZ\rangle_4 = \frac{1}{\sqrt{2}} [|0000\rangle + |1111\rangle] \quad , \quad \hat{Y}^{\otimes 2} \hat{I}^{\otimes 2} |GHZ\rangle_4 = -\frac{1}{\sqrt{2}} [|1100\rangle + |0011\rangle]$$

Magic and Multi-Partite Entanglement in Nuclei

Quantum magic and multipartite entanglement in the structure of nuclei

[Florian Brökemeier](#) ¹, [S. Momme Hengstenberg](#) ¹, [James W. T. Keeble](#) ¹, [Caroline E. P. Robin](#) ^{1,2,*}, [Federico Rocco](#) ¹, and [Martin J. Savage](#) ^{3,†}

Show more 

Phys. Rev. C **111**, 034317 – Published 11 March, 2025

DOI: <https://doi.org/10.1103/PhysRevC.111.034317>

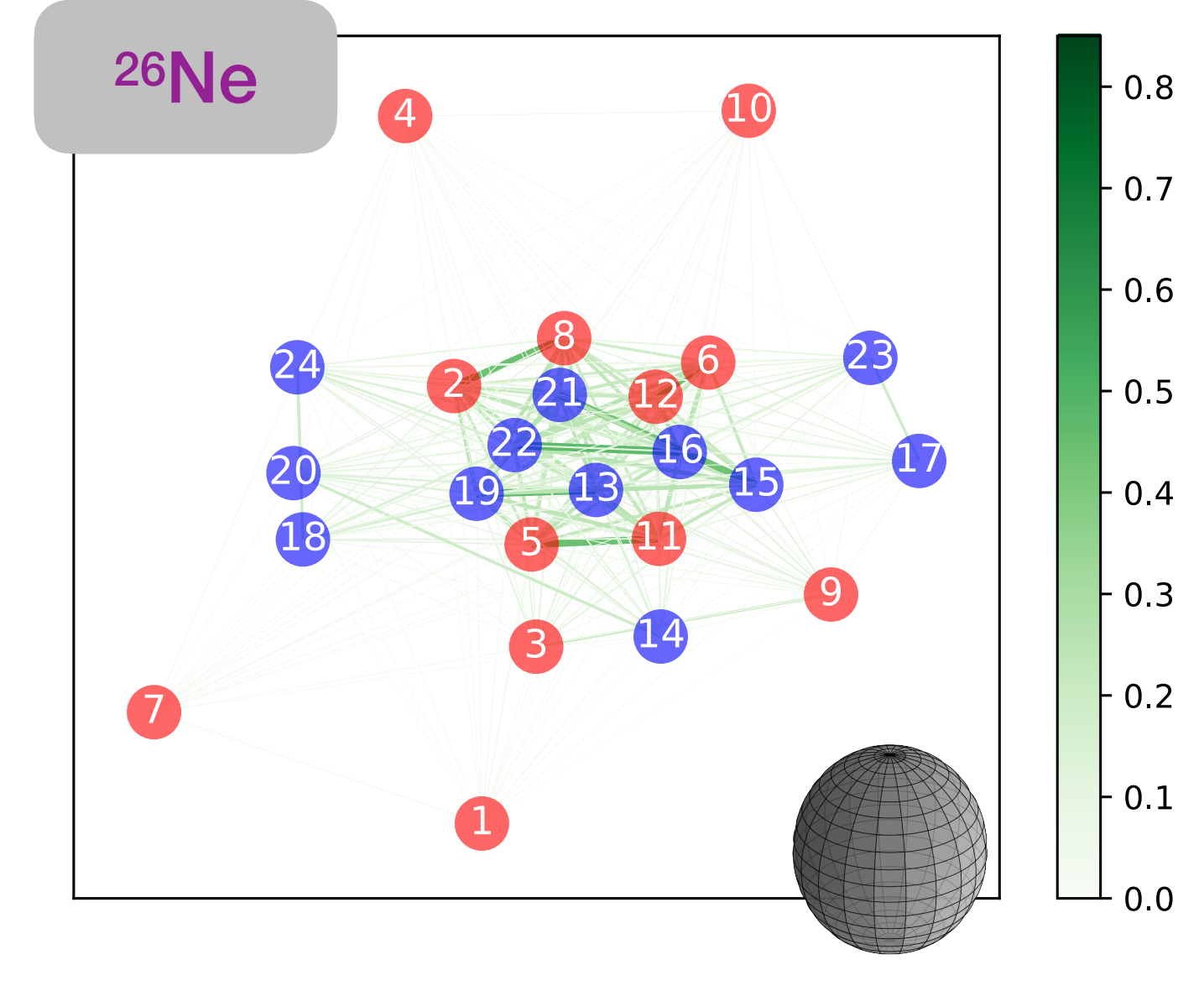
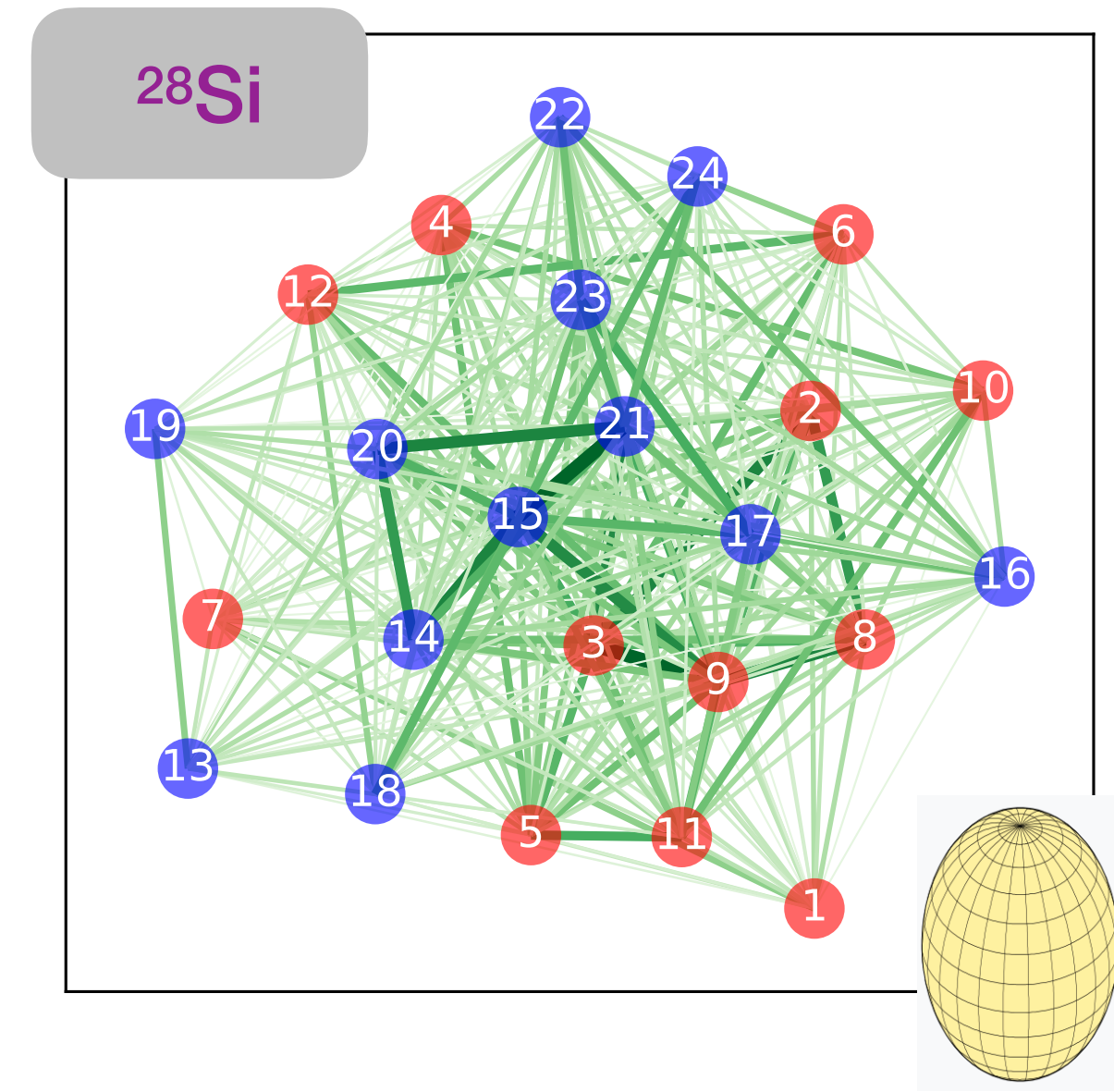
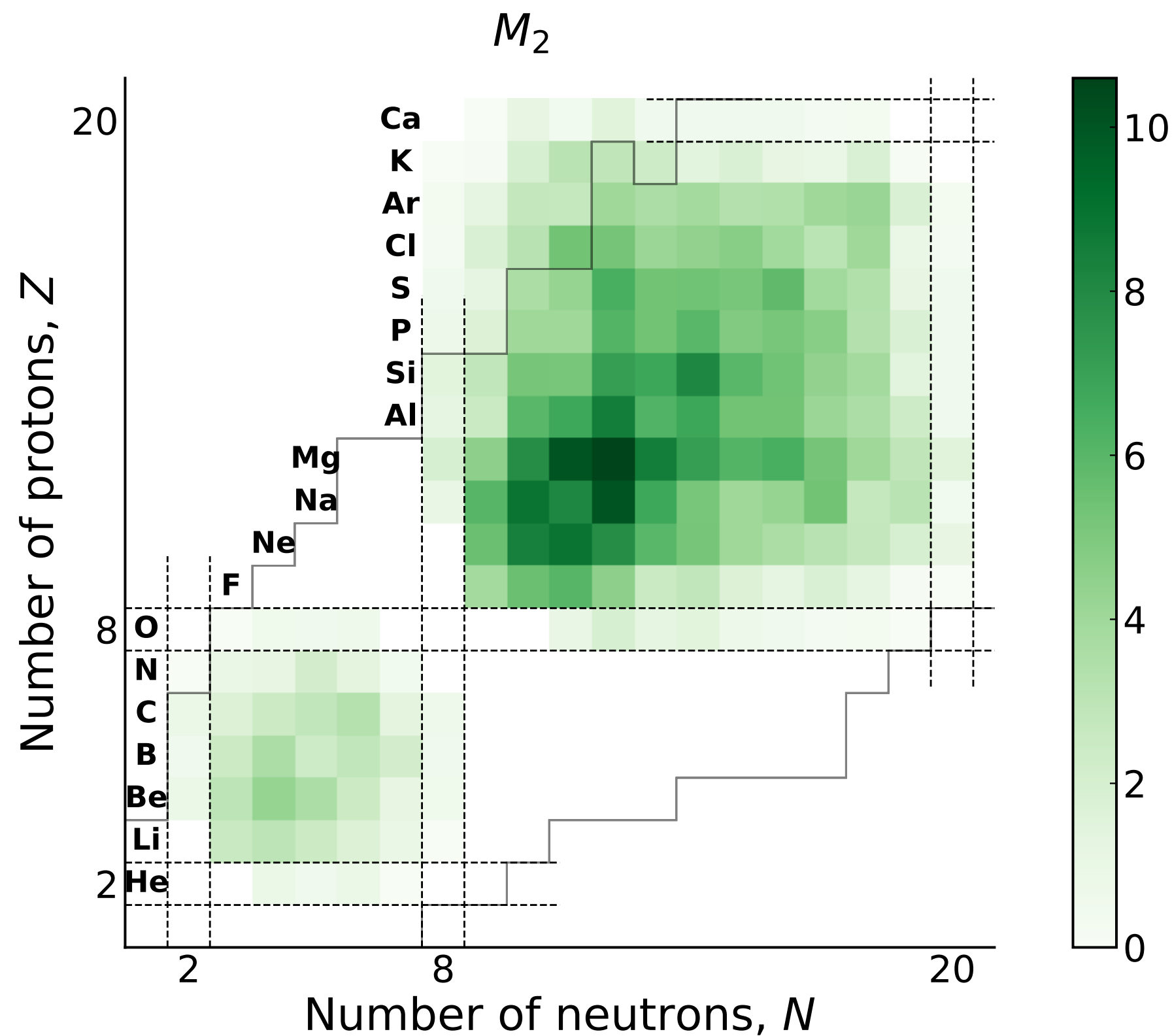

8-tangles

Magic and Multi-Partite Entanglement in Nuclei

Quantum magic and multipartite entanglement in the structure of nuclei

Florian Brökemeier ¹, S. Momme Hengstenberg ¹, James W. T. Keeble ¹, Caroline E. P. Robin ^{1,2,*}, Federico Rocco ¹, and Martin J. Savage ^{3,†}

Show more

Phys. Rev. C **111**, 034317 – Published 11 March, 2025

DOI: <https://doi.org/10.1103/PhysRevC.111.034317>

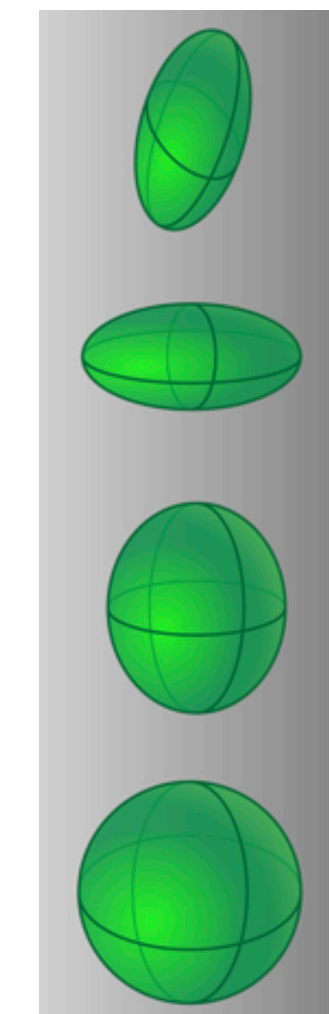
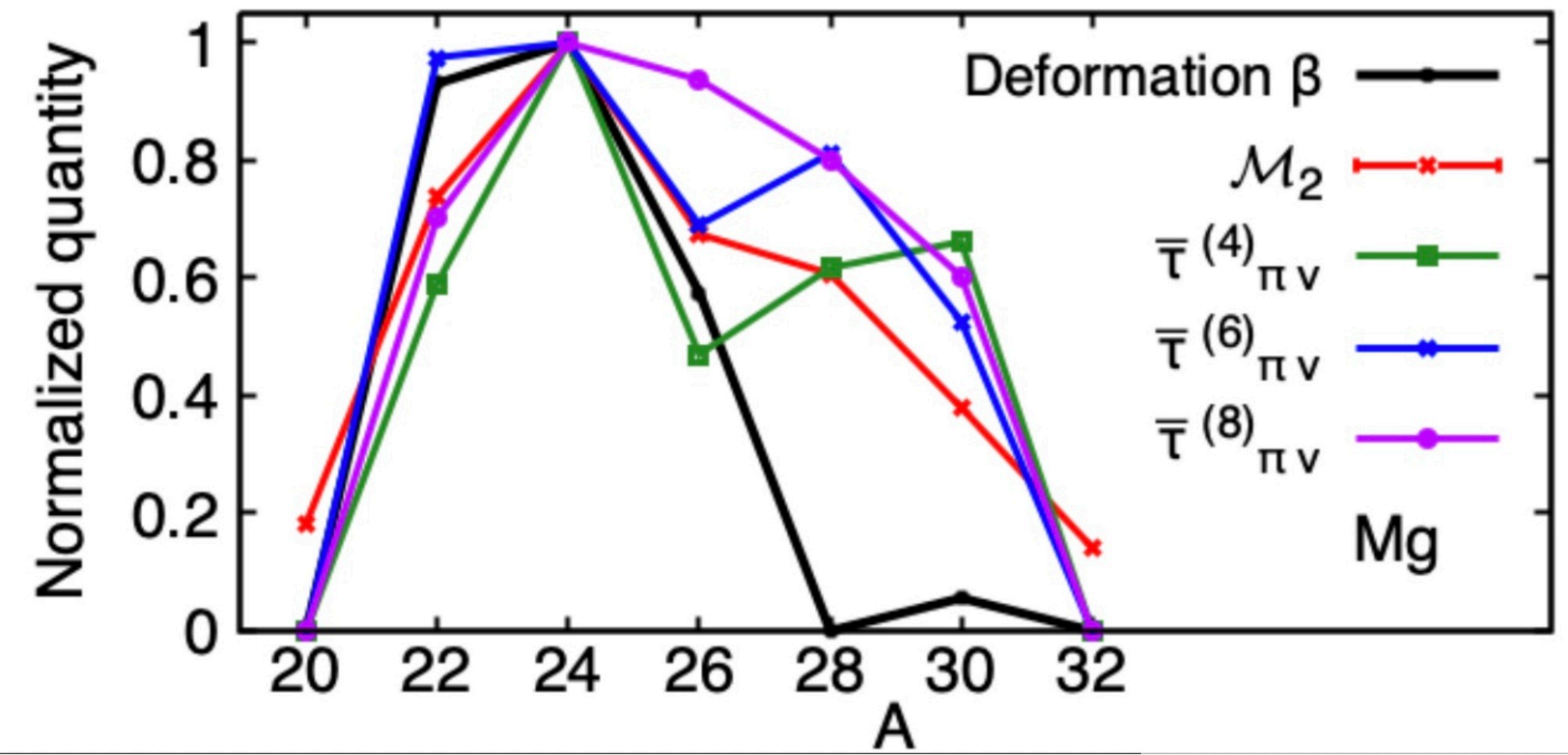
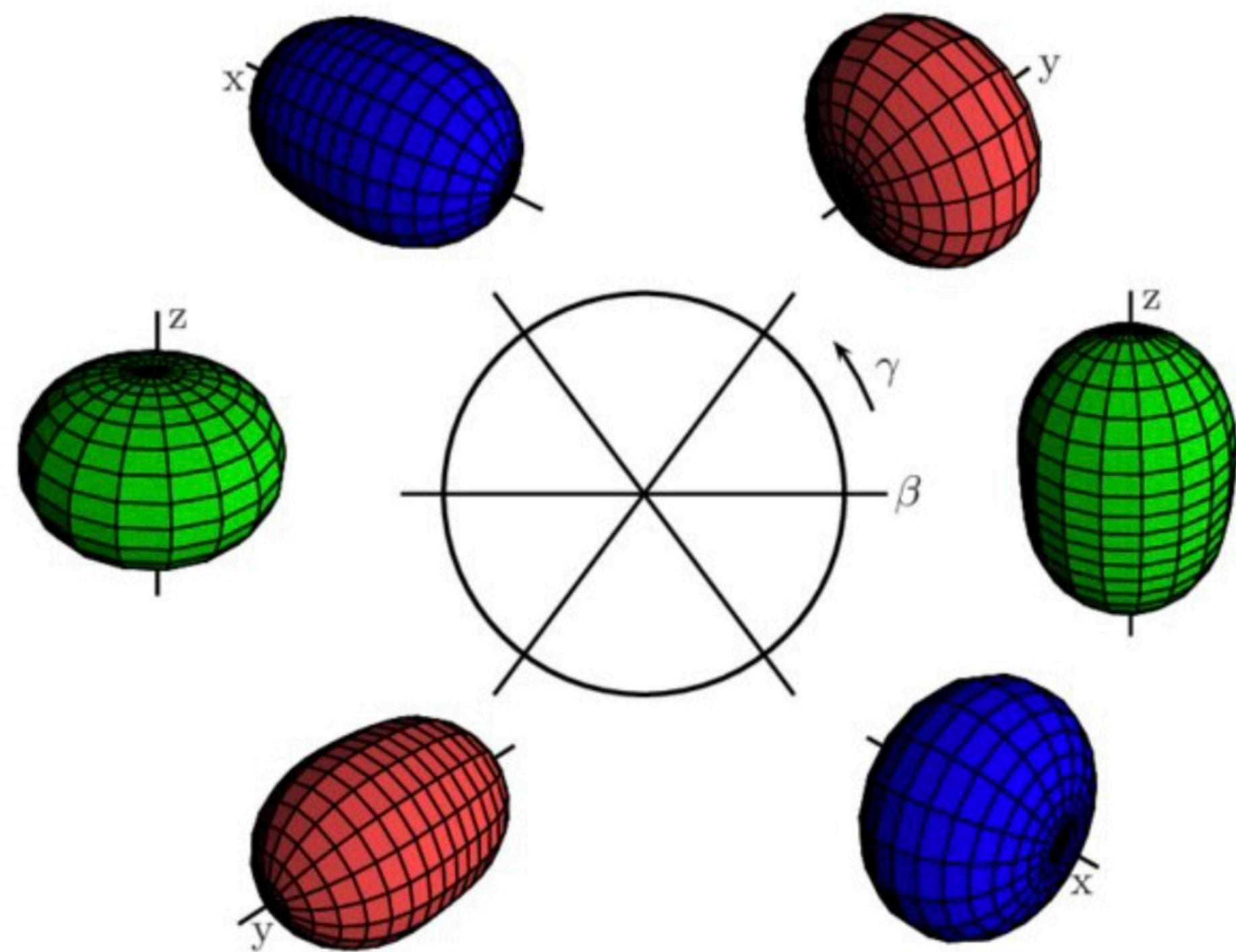

Shape co-existence

Restricted Boltzmann Machines Infidelity and Quantum Complexity

Neural Quantum States in Non-Stabilizer Regimes: Benchmarks with Atomic Nuclei

James W. T. Keeble ^{1,*} Alessandro Lovato ^{2,3,4,†} and Caroline E. P. Robin ^{1,5,‡}

arXiv:2603.28646v1 [nucl-th] 30 Mar 2026

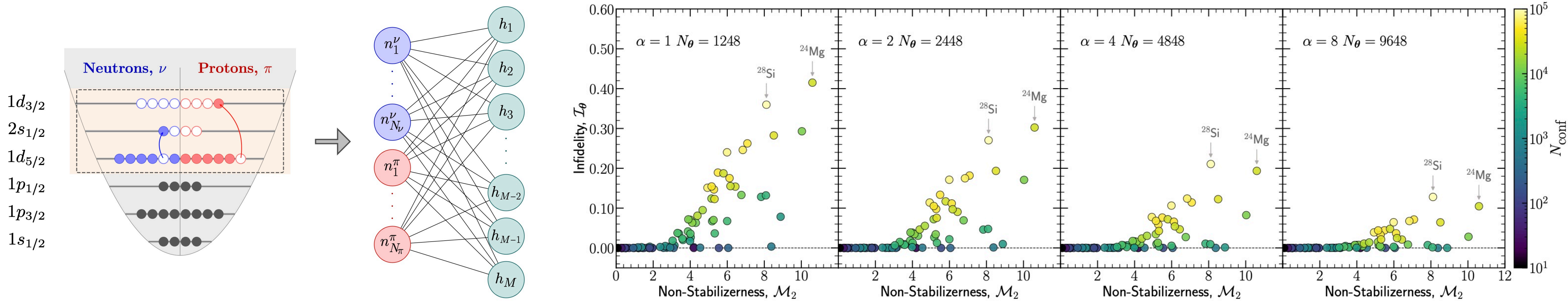

Complexity Rearrangement, Effective Model Spaces and Symmetries

Home > The European Physical Journal A > Article

Multi-body entanglement and information rearrangement in nuclear many-body systems: a study of the Lipkin–Meshkov–Glick model

Regular Article – Theoretical Physics | Published: 17 October 2023

Volume 59, article number 231, (2023) [Cite this article](#)

S. Momme Hengstenberg, Caroline E. P. Robin & Martin J. Savage

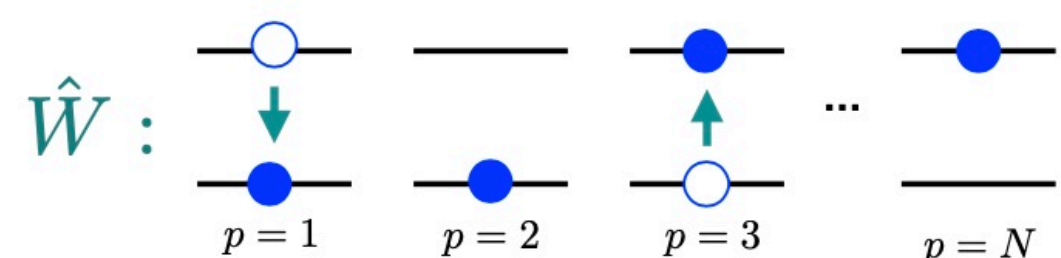
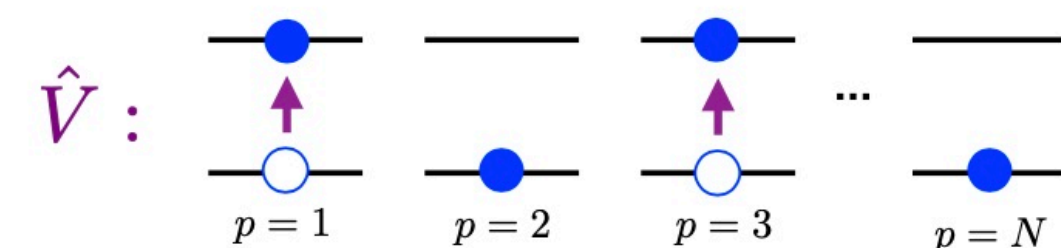
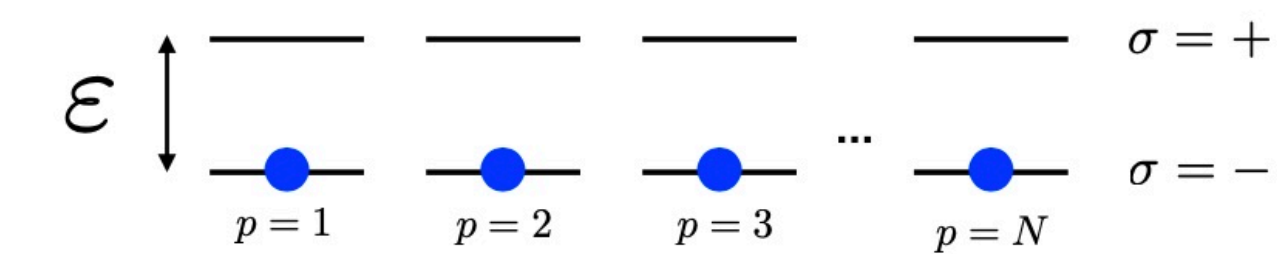

$$\begin{aligned} \hat{H} &= \frac{\varepsilon}{2} \sum_{\sigma p} \sigma \hat{c}_{p\sigma}^\dagger \hat{c}_{p\sigma} - \frac{V}{2} \sum_{pq\sigma} \hat{c}_{p\sigma}^\dagger \hat{c}_{q\sigma}^\dagger \hat{c}_{q-\sigma} \hat{c}_{p-\sigma} \\ &\quad - \frac{W}{2} \sum_{pq\sigma} \hat{c}_{p\sigma}^\dagger \hat{c}_{q-\sigma}^\dagger \hat{c}_{q\sigma} \hat{c}_{p-\sigma} , \\ &= \varepsilon \hat{J}_z - \frac{V}{2} (\hat{J}_+^2 + \hat{J}_-^2) - \frac{W}{2} (\hat{J}_+ \hat{J}_- + \hat{J}_- \hat{J}_+ - \hat{N}) , \end{aligned}$$

$$\begin{pmatrix} \hat{c}_{p+}(\beta) \\ \hat{c}_{p-}(\beta) \end{pmatrix} = \begin{pmatrix} \cos(\beta/2) & -\sin(\beta/2) \\ \sin(\beta/2) & \cos(\beta/2) \end{pmatrix} \begin{pmatrix} \hat{c}_{p+} \\ \hat{c}_{p-} \end{pmatrix}$$

Full theory has rotational symmetry

Truncated Hamiltonian does not

Angular optimization of truncated space

Complexity Rearrangement, Effective Model Spaces and Symmetries

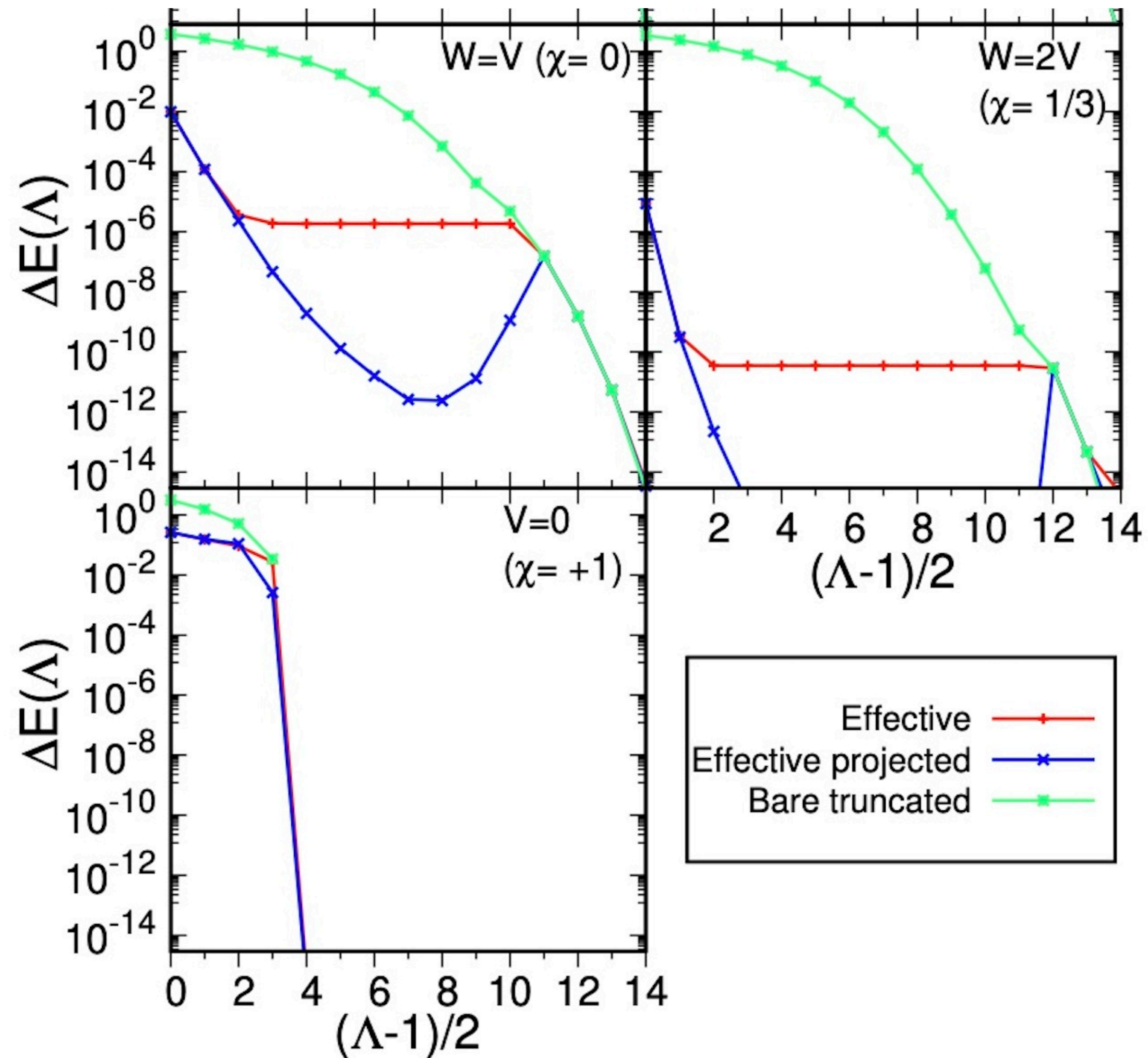

Naive truncation: power law corrections

Optimized truncation: exponential corrections
over some of the Hilbert space

Likely to be of utility more generally for EFT
developments

Complexity Rearrangement, Effective Model Spaces and Symmetries

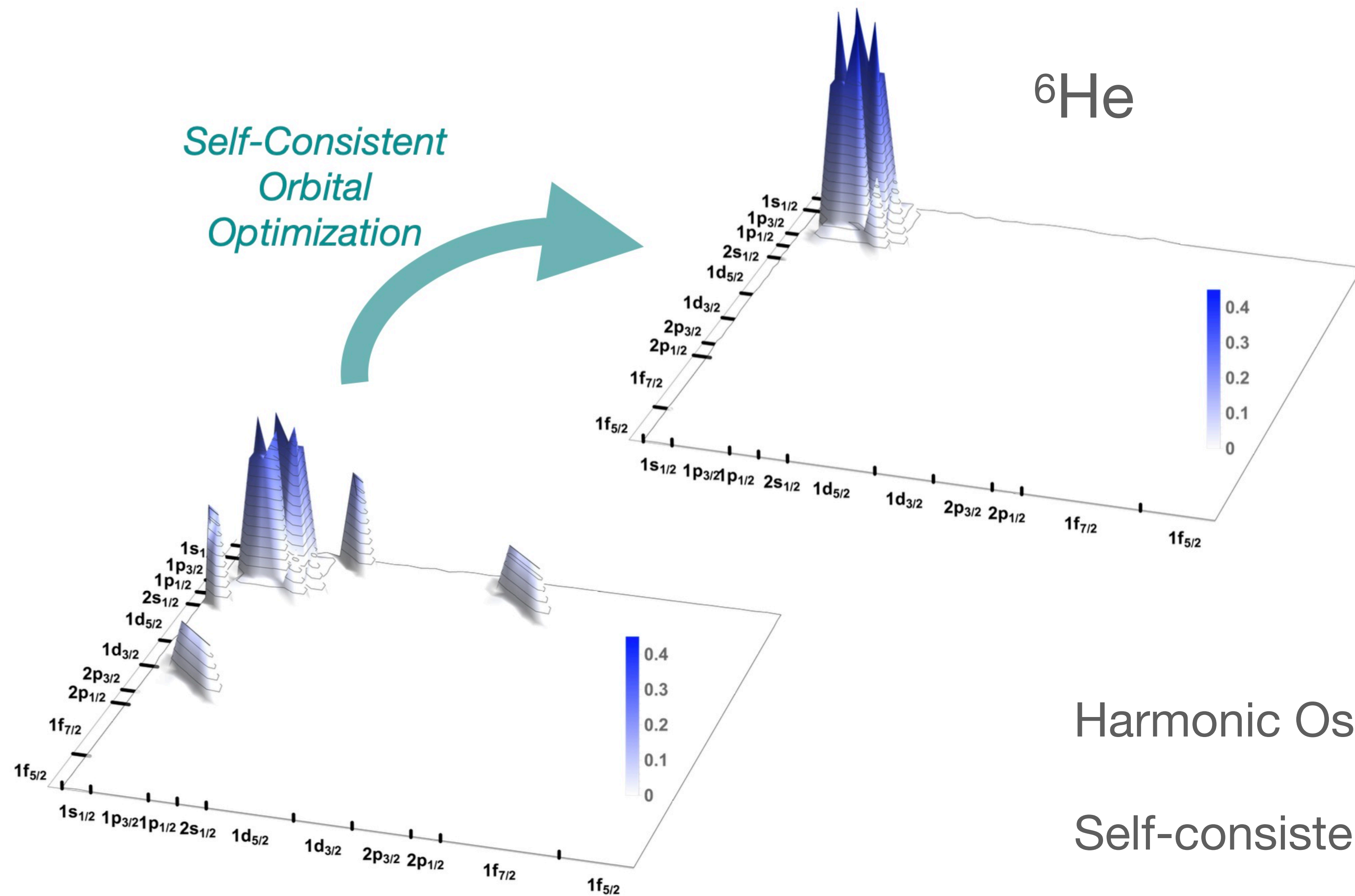

Harmonic Oscillator wave function (lower)

Self-consistent wave function (upper)

Stabilizer Acceleration in Many-Body Systems

Stabilizer-accelerated quantum many-body ground-state estimation

Caroline E. P. Robin *

Show more

Phys. Rev. A 112, 052408 – Published 3 November, 2025

Ex

$$\hat{H} = \underbrace{\sum_{P \in \mathcal{S}} a_P \hat{P}}_{\hat{H}_{stab}} + \underbrace{\sum_{P \in \mathcal{G}_N(H) \setminus \mathcal{S}} a_P \hat{P}}_{\hat{W}} \quad |\Psi_s\rangle = \prod_{i=1}^N C_i |G\rangle = \prod_{i=1}^N C_i \prod_{e \in E} CZ_e |+\rangle^{\otimes N}$$

Explore all possible decompositions into Stabilizer Groups

$$\tilde{H} = \frac{1}{2} \sum_i Z_i - \frac{\bar{v}_x}{2(N-1)} \sum_{i < j} (X_i X_j + \chi Y_i Y_j)$$

$$\langle -Z_1, -Z_2, \dots, -Z_N \rangle \quad \langle Y_1 Y_N, Y_2 Y_N, \dots, Y_{N-1} Y_N, (-1)^N Z_1 Z_2 \dots Z_N \rangle \quad \langle X_1 X_N, X_2 X_N, \dots, X_{N-1} X_N, (-1)^N Z_1 Z_2 \dots Z_N \rangle$$

Stabilizer Acceleration in Many-Body Systems

Stabilizer-accelerated quantum many-body ground-state estimation

Caroline E. P. Robin *

Show more

Phys. Rev. A 112, 052408 – Published 3 November, 2025

Ex

$$\tilde{H} = \frac{1}{2} \sum_i Z_i - \frac{\bar{v}_x}{2(N-1)} \sum_{i < j} (X_i X_j + \chi Y_i Y_j)$$

$$|\Phi(\theta)\rangle = e^{-\theta \hat{J}_z} |\Psi_{s,2}\rangle^{(N)},$$

$$= \prod_{i=1}^N e^{-\theta Z_i} |\Psi_{s,2}\rangle^{(N)}$$

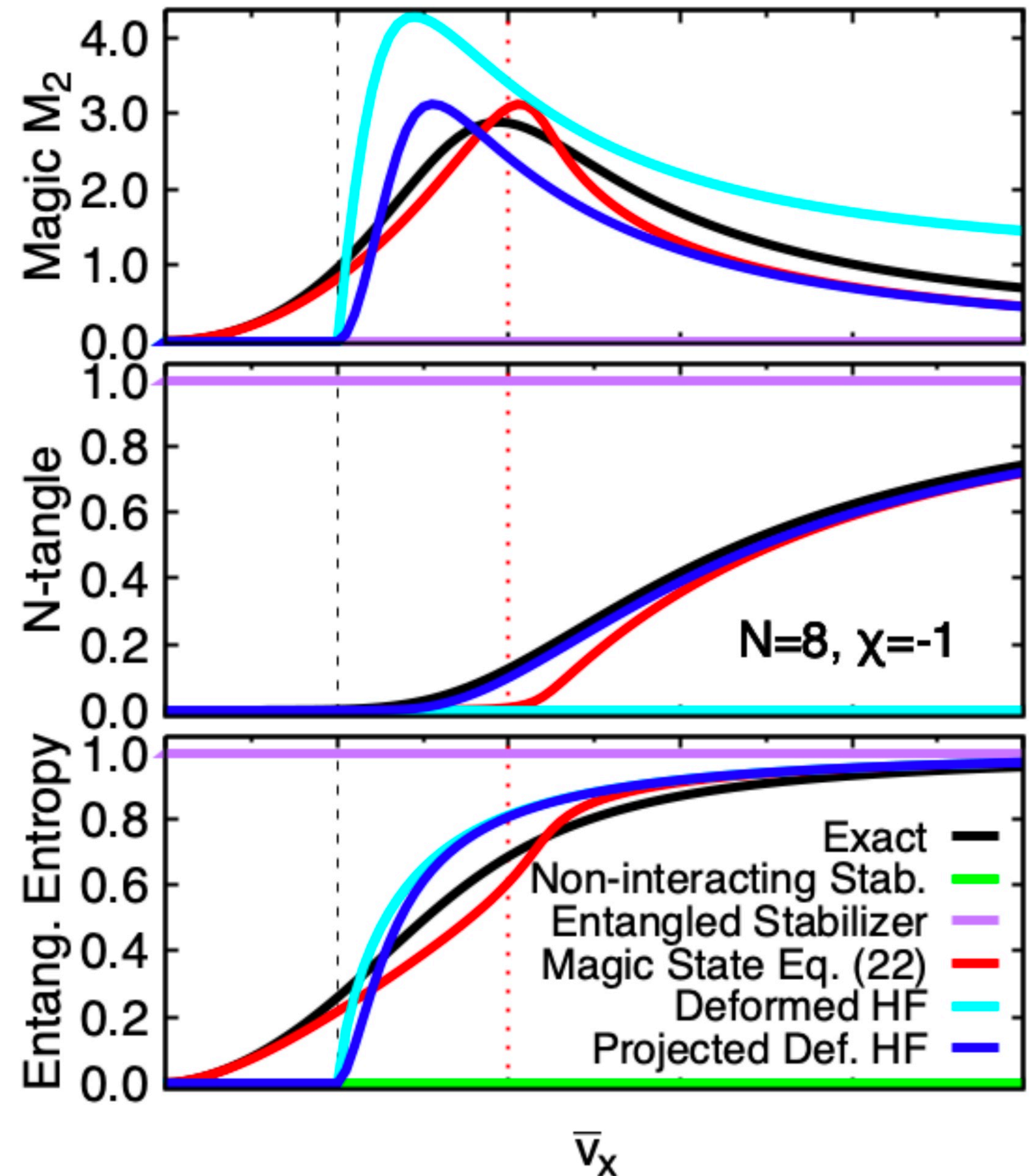

Part-2

Quantum Complexity

Quantum Complexity for Fundamental Quantum Many-Body Systems

- Essential for optimal quantum simulations in fundamental physics - balancing quantum and classical resources
- At the beginning stages
- Potentially new methods for classical simulations

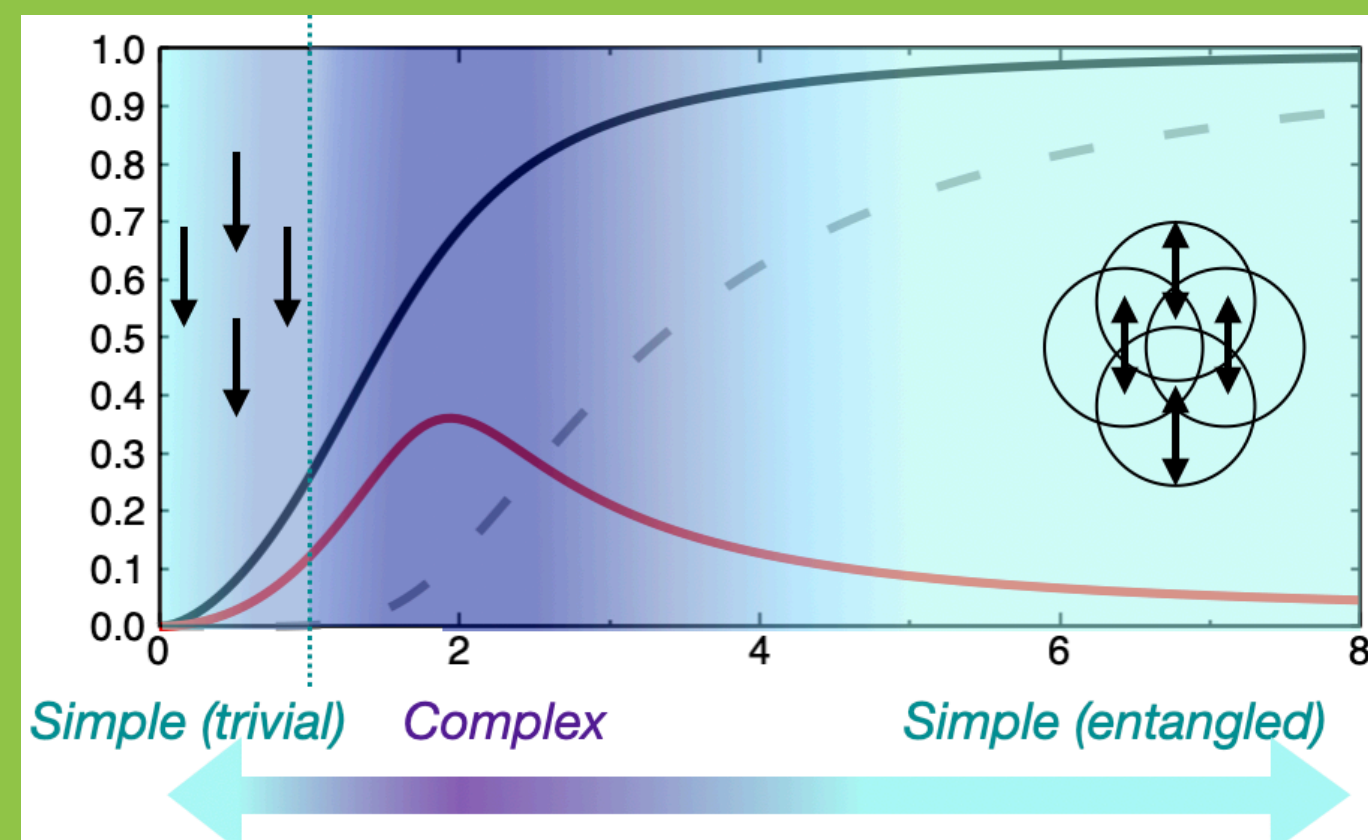

FIN