

Directed flow of identified particles from Beam Energy Scan Au+Au collisions

Subhash Singha
(on behalf of STAR Collaboration)

INT Program INT-16-3
Exploring the QCD Phase Diagram through Energy Scans
September 19-October 14, 2016



Outline

- ★ Directed flow in heavy-ion collisions
- ★ Beam energy scan (BES) program at RHIC
- ★ STAR detector at RHIC
- ★ Measurements at lower energies (AGS/SPS)
- ★ Results from STAR
- ★ Comparison of data with available models
- ★ Summary and outlook

Directed flow in heavy-ion collisions

$$E \frac{d^3 N}{dp^3} = \frac{1}{2\pi} \frac{d^2 N}{p_T dp_T dy} [1 + 2v_1 \cos(\phi - \Psi_R) + 2v_2 \cos 2(\phi - \Psi_R) + \dots]$$

directed flow

elliptic flow

$$v_1 \sim \langle \cos(\phi - \Psi_R) \rangle$$

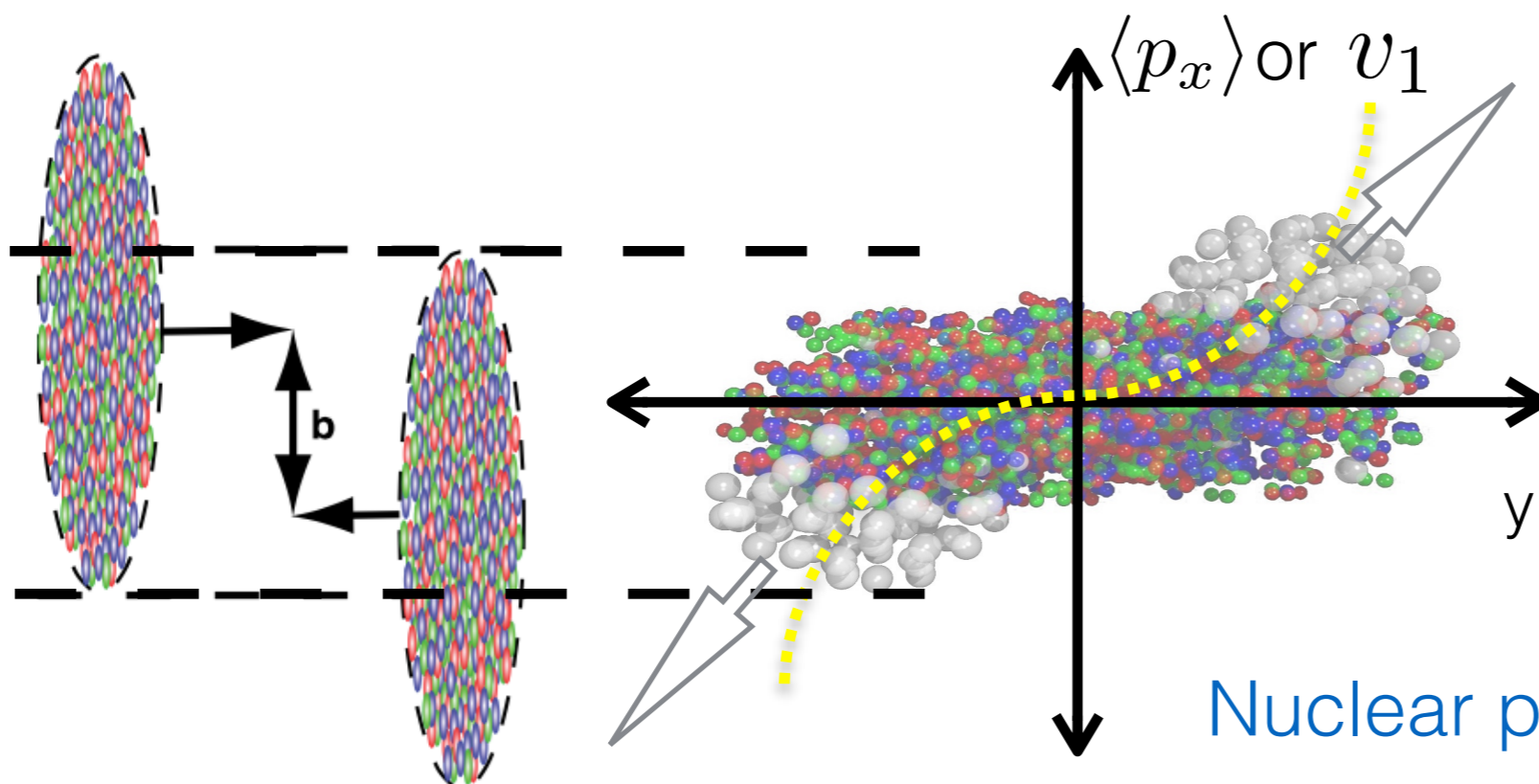

Nuclear passage time: $2R/\gamma \sim 0.1$ fm/c
 Probes early stages of collisions

Rapidity dependence of directed flow

L. P. Csernai et al., *Phys. Lett. B* **458**, 454 (1999)

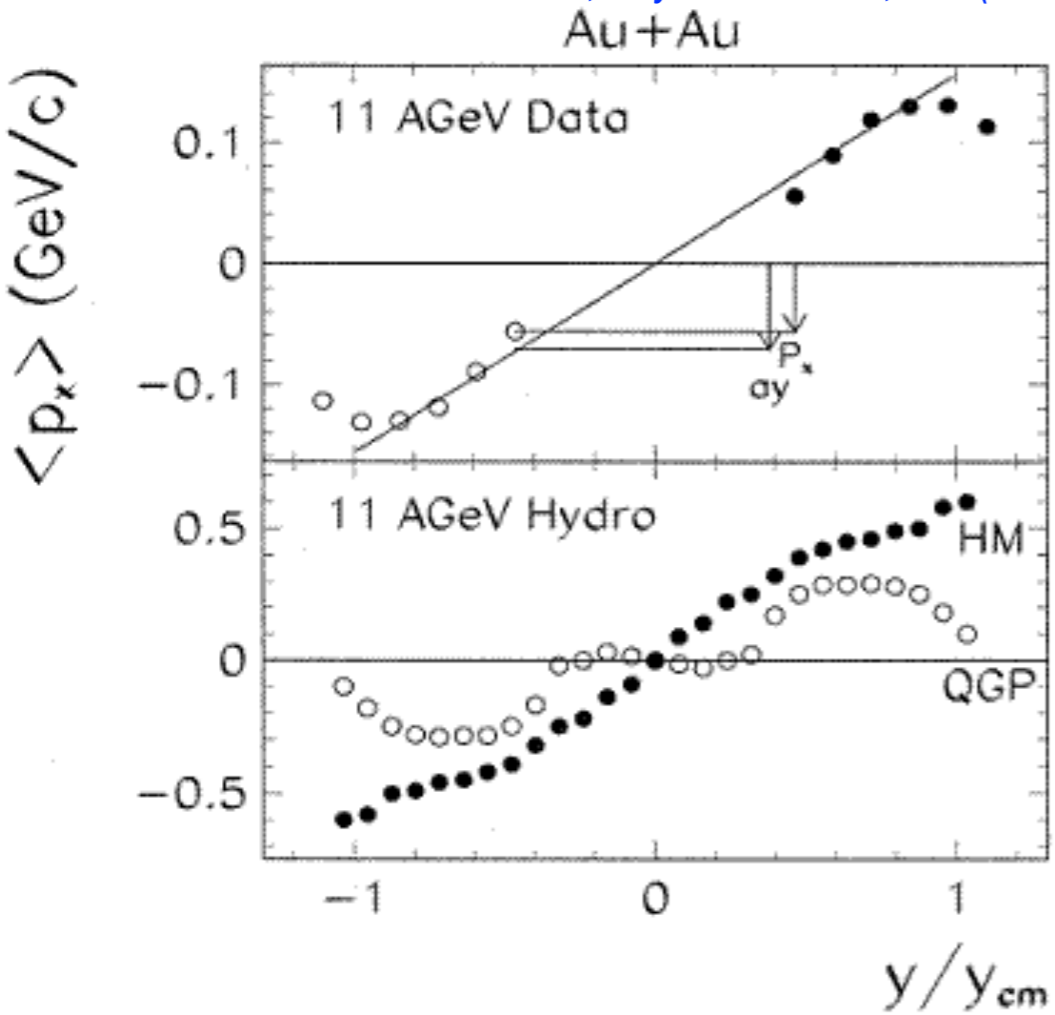

Models with QGP predicted a “wiggle”/ flat v_1 at mid-rapidity due to a 1st order phase transition

Rapidity dependence of directed flow

L. P. Csernai et al., Phys. Lett. **B458**, 454 (1999)

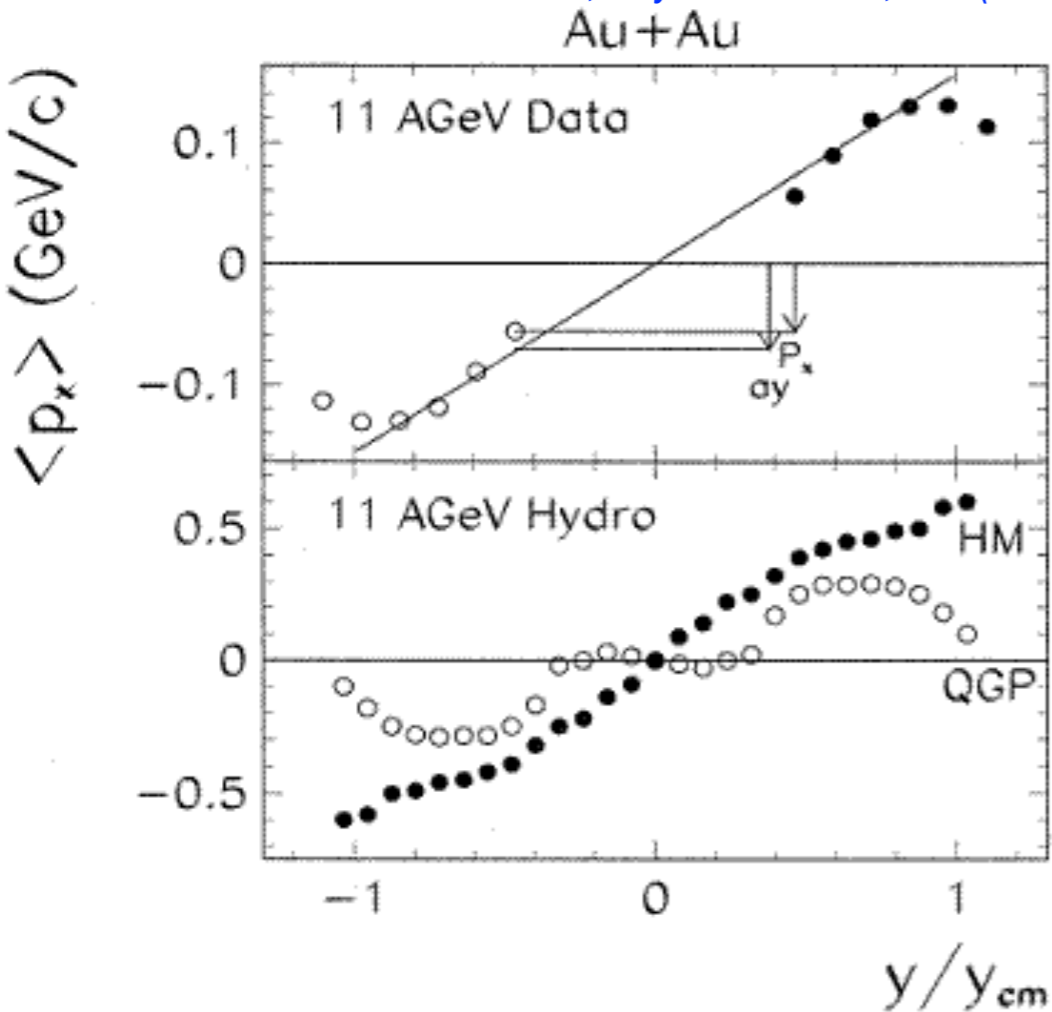

R. Snellings et al., Phys. Rev. Lett. **84**, 2803 (2000)

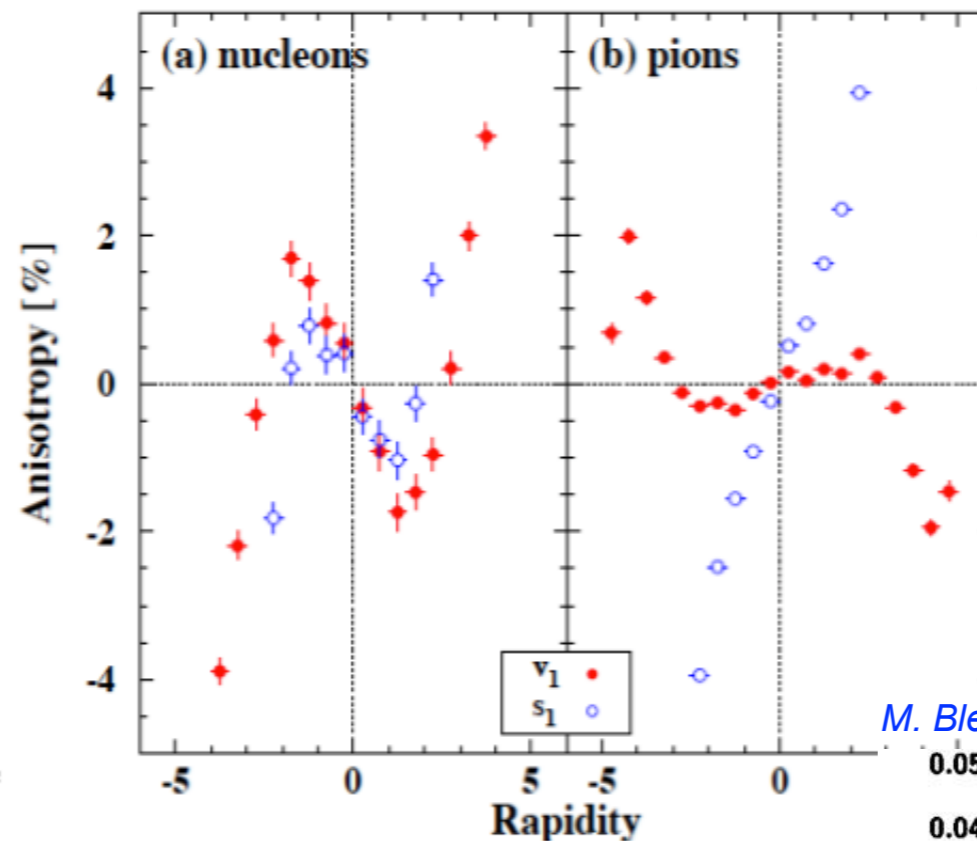

M. Bleicher et al., Phys. Lett. **B526**, 309 (2002)

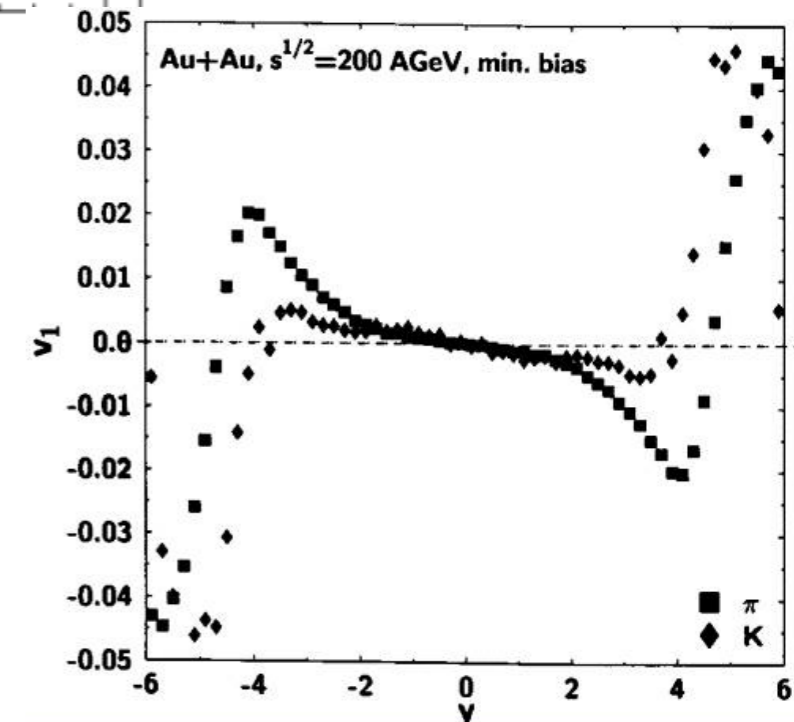

Models with QGP predicted a “wiggle”/ flat v_1 at mid-rapidity due to a 1st order phase transition

Models **without QGP** may also give a “wiggle” structure e.g., Baryon stopping + positive space-momentum correlation

Directed flow and phase transition

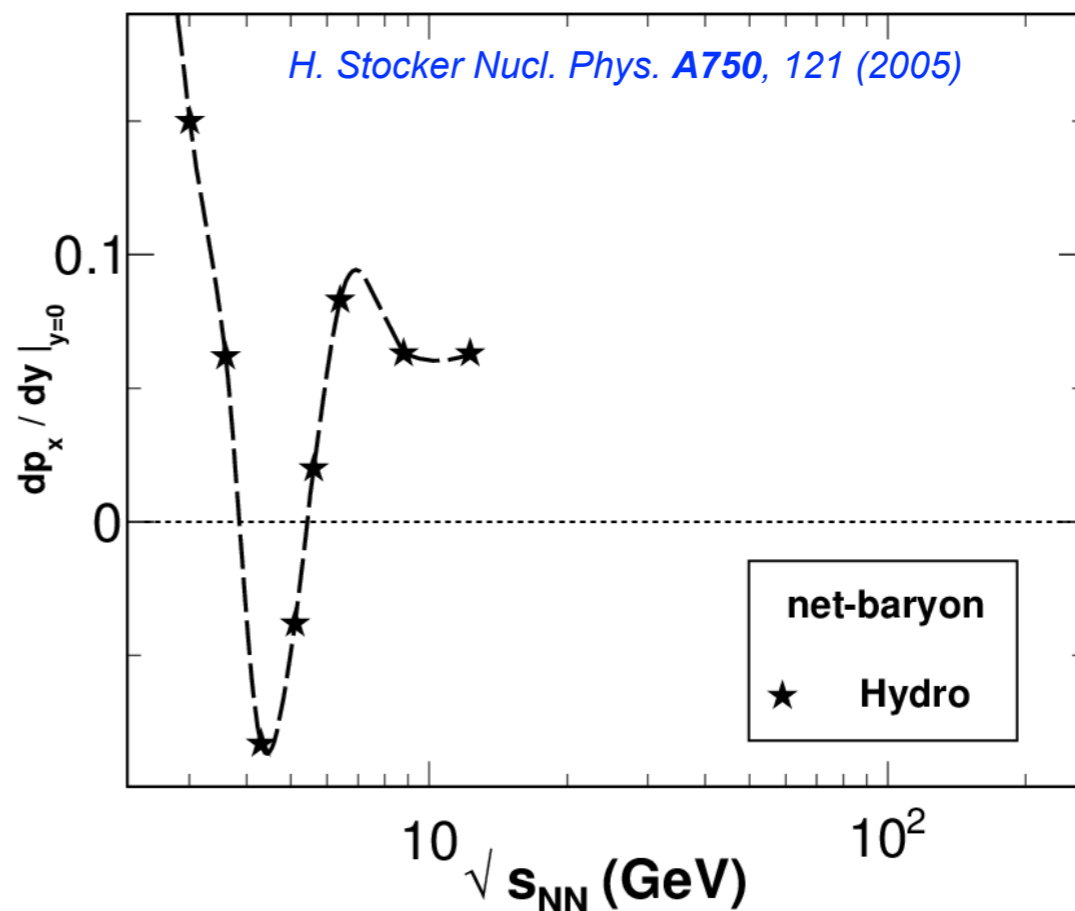
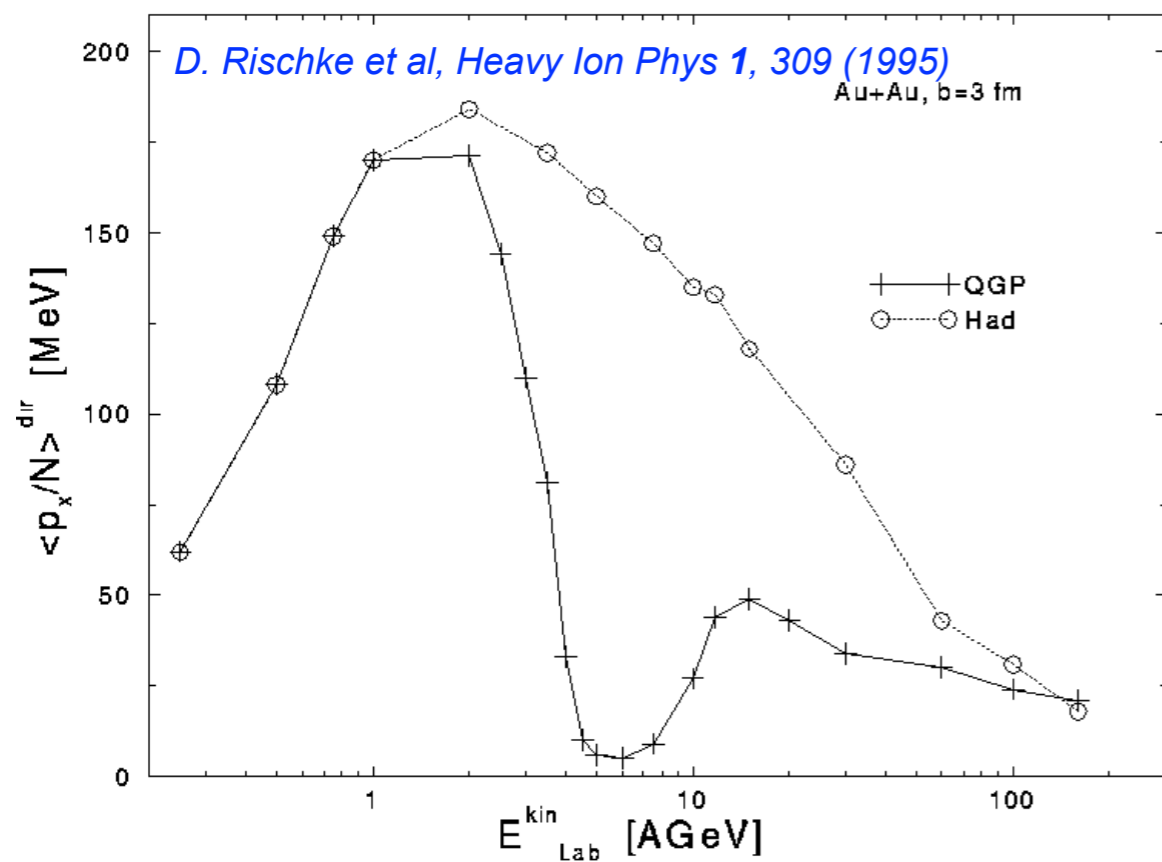

Model calculations indicated that v_1 -slope (specially for baryons) at mid-rapidity is sensitive to the EoS of the system

R. Snellings, New J of Phys 13, 055008 (2011)
P. Huovinen et al, Nucl Phys A837, 26 (2010)

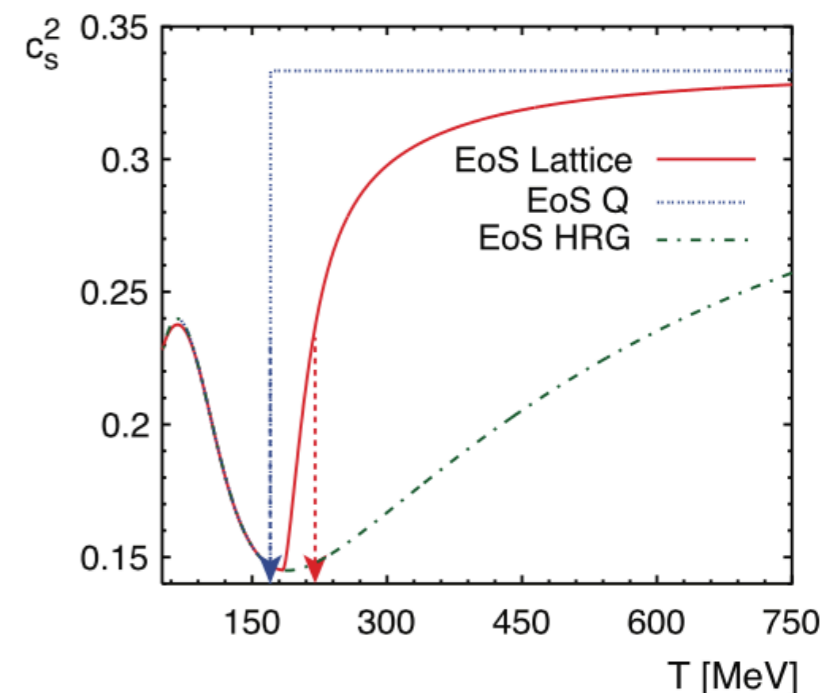

BES-I at RHIC

J. Cleymans et al PRC 73, 034905 (2006)

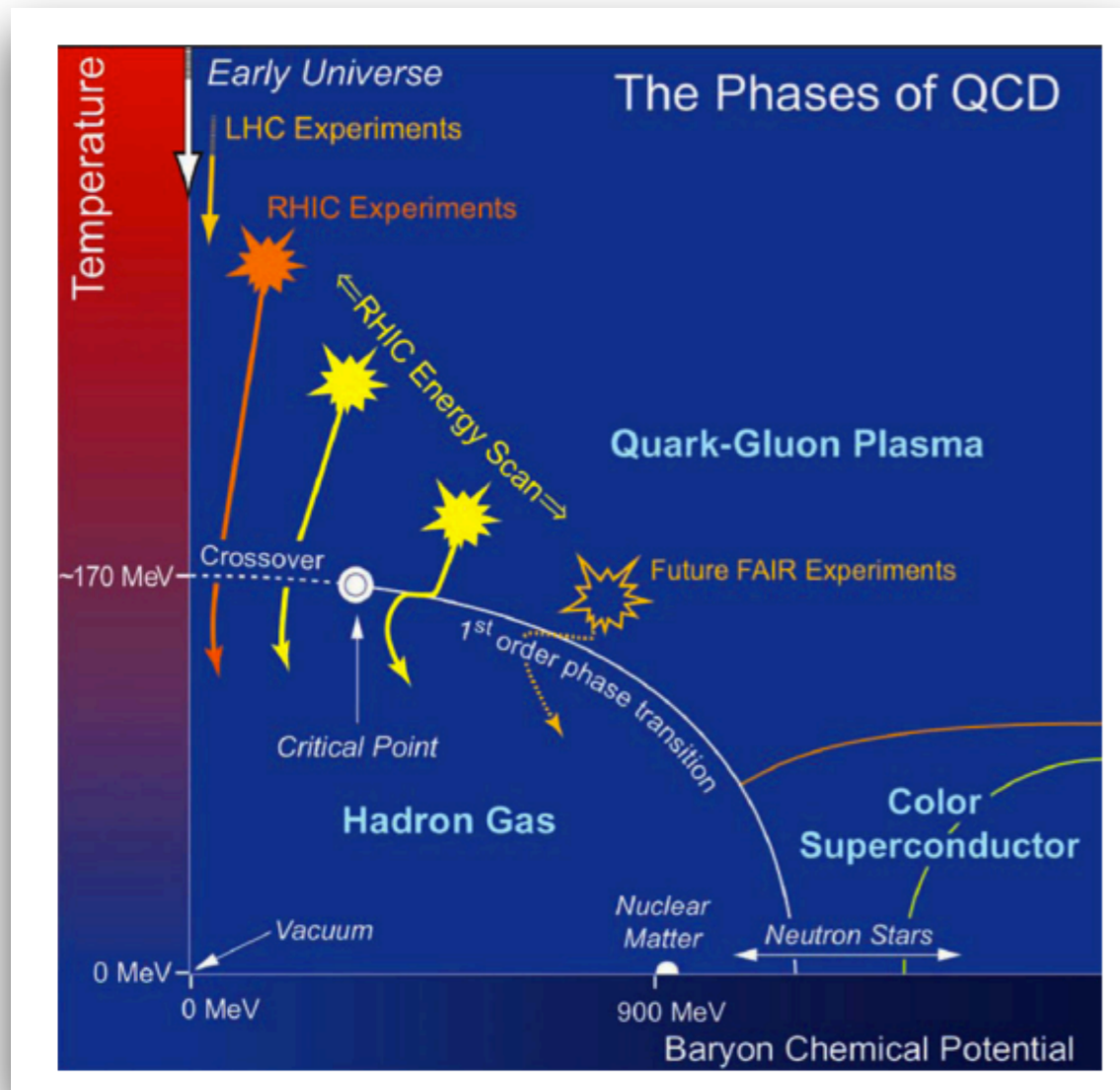

Energy(GeV)	Events (M)	T (MeV)	μ_B (MeV)
7.7	4	140	422
11.5	12	152	316
14.5	18	156	264
19.6	36	160	206
27	70	162	156
39	130	164	112
62.4	67	165	73
200	350	166	25

BES program: To explore QCD phase diagram by varying beam energy

- ◆ Map turn-off of QGP signatures
- ◆ Search for Critical Point
- ◆ Search for First-Order Phase Transition

<https://drupal.star.bnl.gov/STAR/starnotes/public/sn0598>

Directed flow (v_1) is a key observable to search for the signature of a 1st order phase transition

BES-I at RHIC

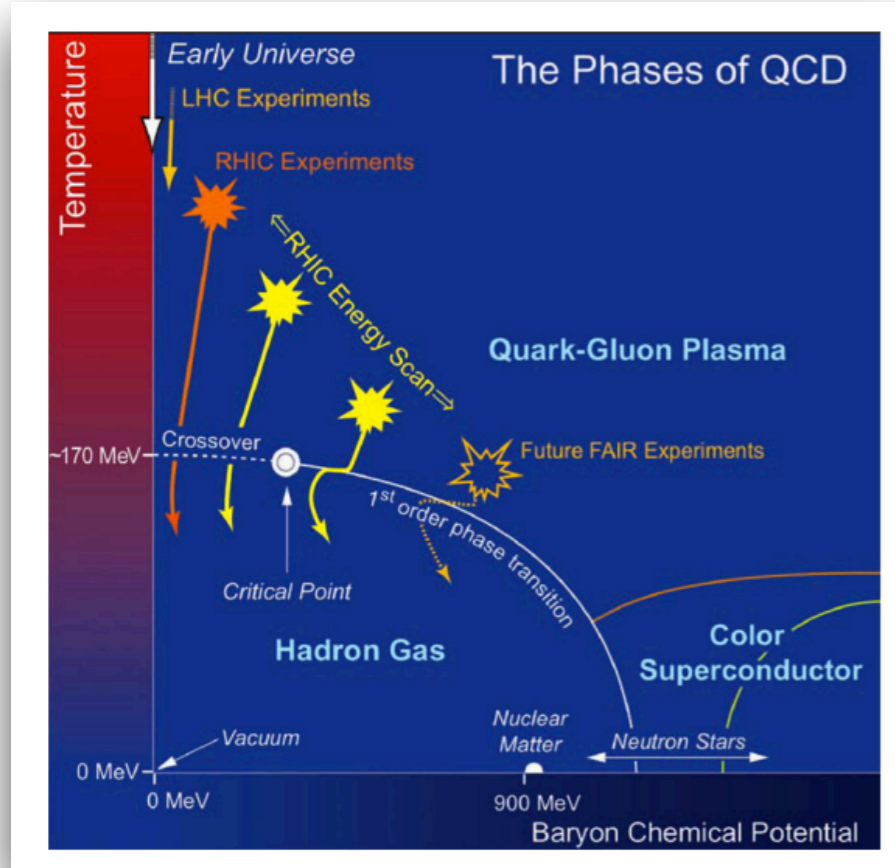

R. Snellings, New J of Phys 13, 055008 (2011)
P. Huovinen et al, Nucl Phys A837, 26 (2010)

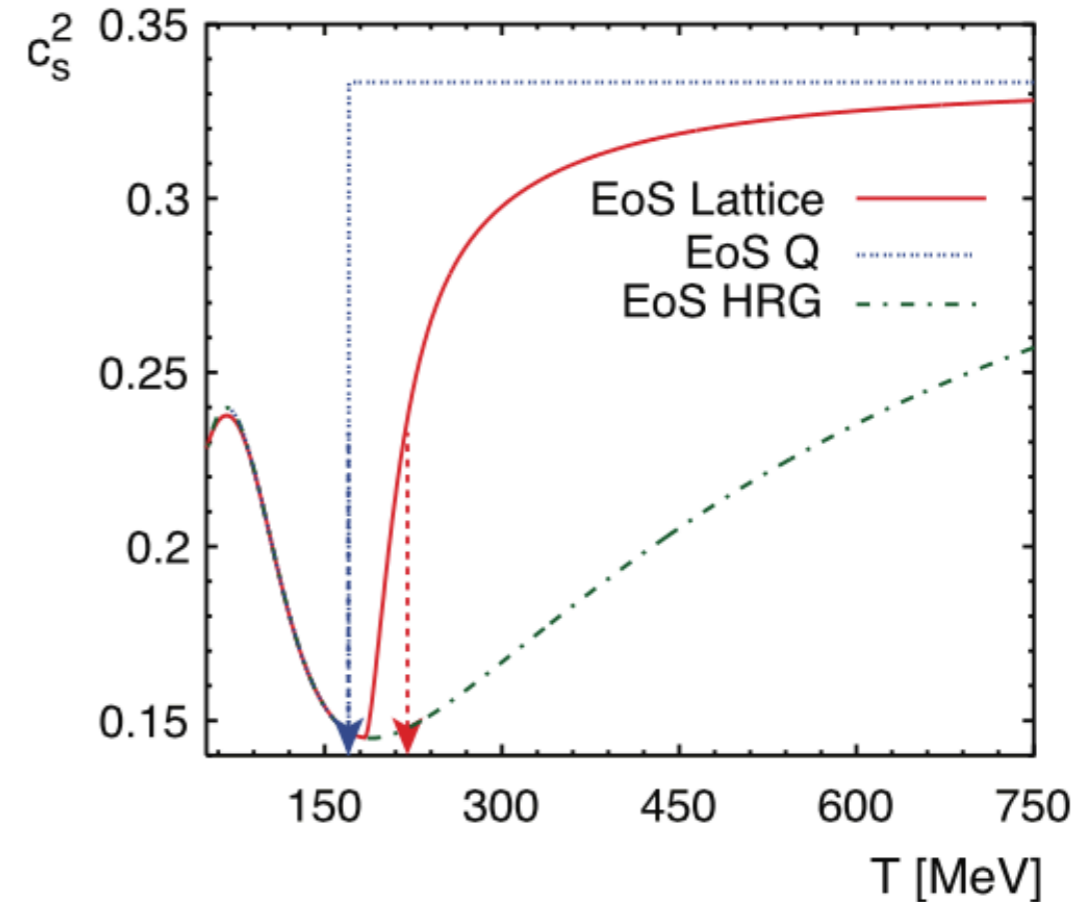

<https://drupal.star.bnl.gov/STAR/starnotes/public/sn0598>

Large softening signature



First-Order Phase Transition

Smaller softening signature



Could have other explanations
(e.g., crossover)

STAR Detector

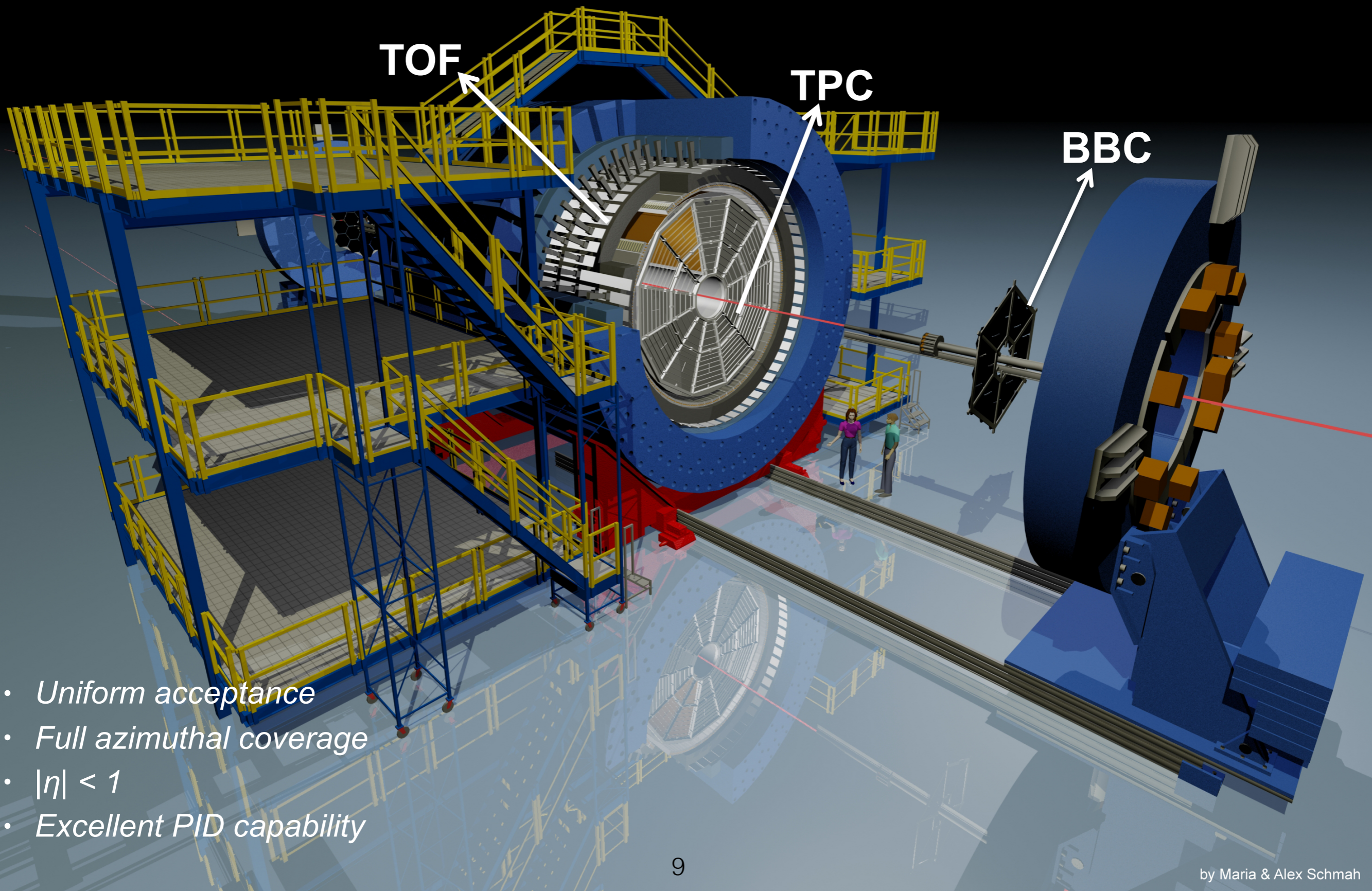

TOF

TPC

BBC

- *Uniform acceptance*
- *Full azimuthal coverage*
- $|\eta| < 1$
- *Excellent PID capability*

STAR Detector

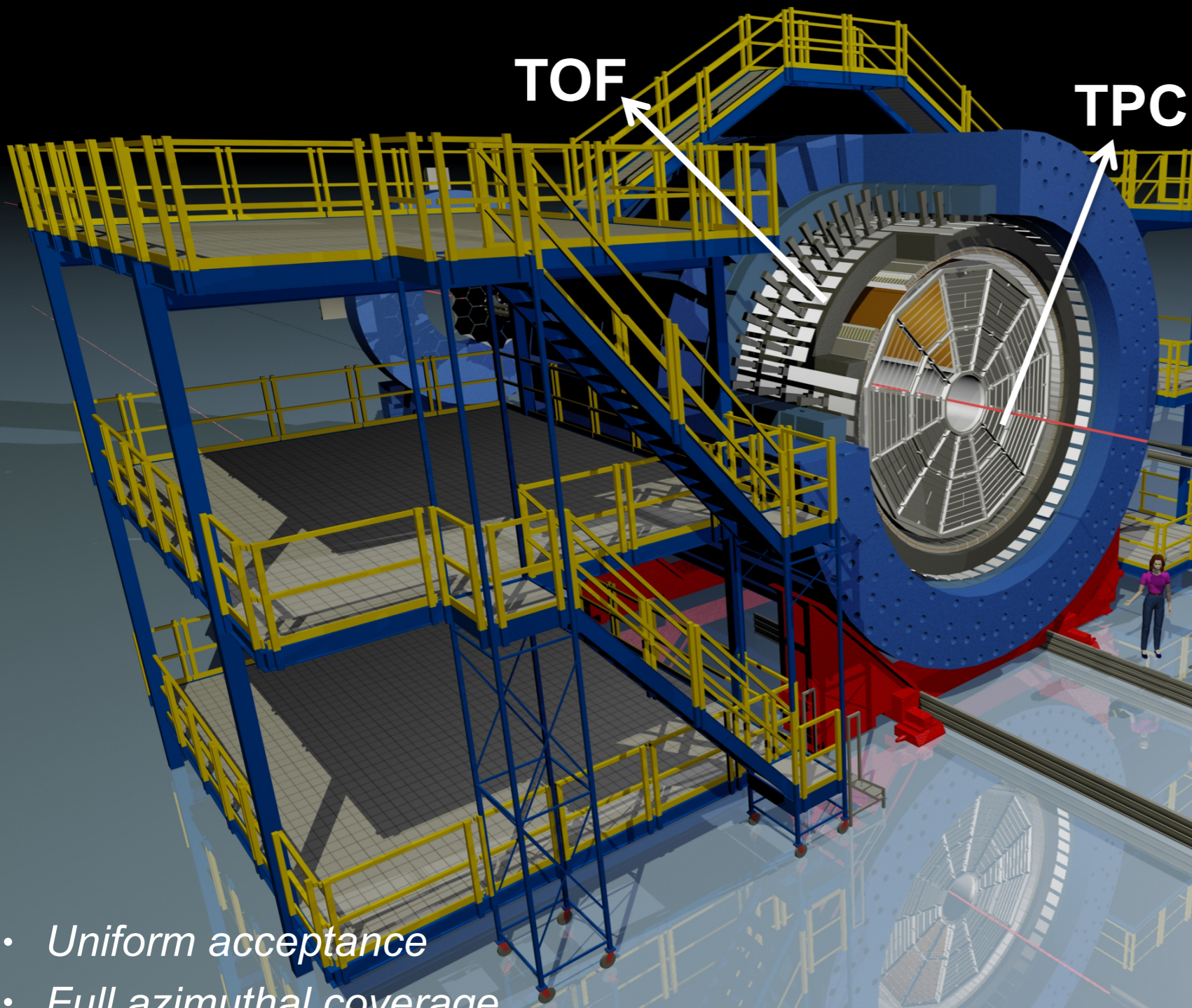

- *Uniform acceptance*
- *Full azimuthal coverage*
- $|\eta| < 1$
- *Excellent PID capability*

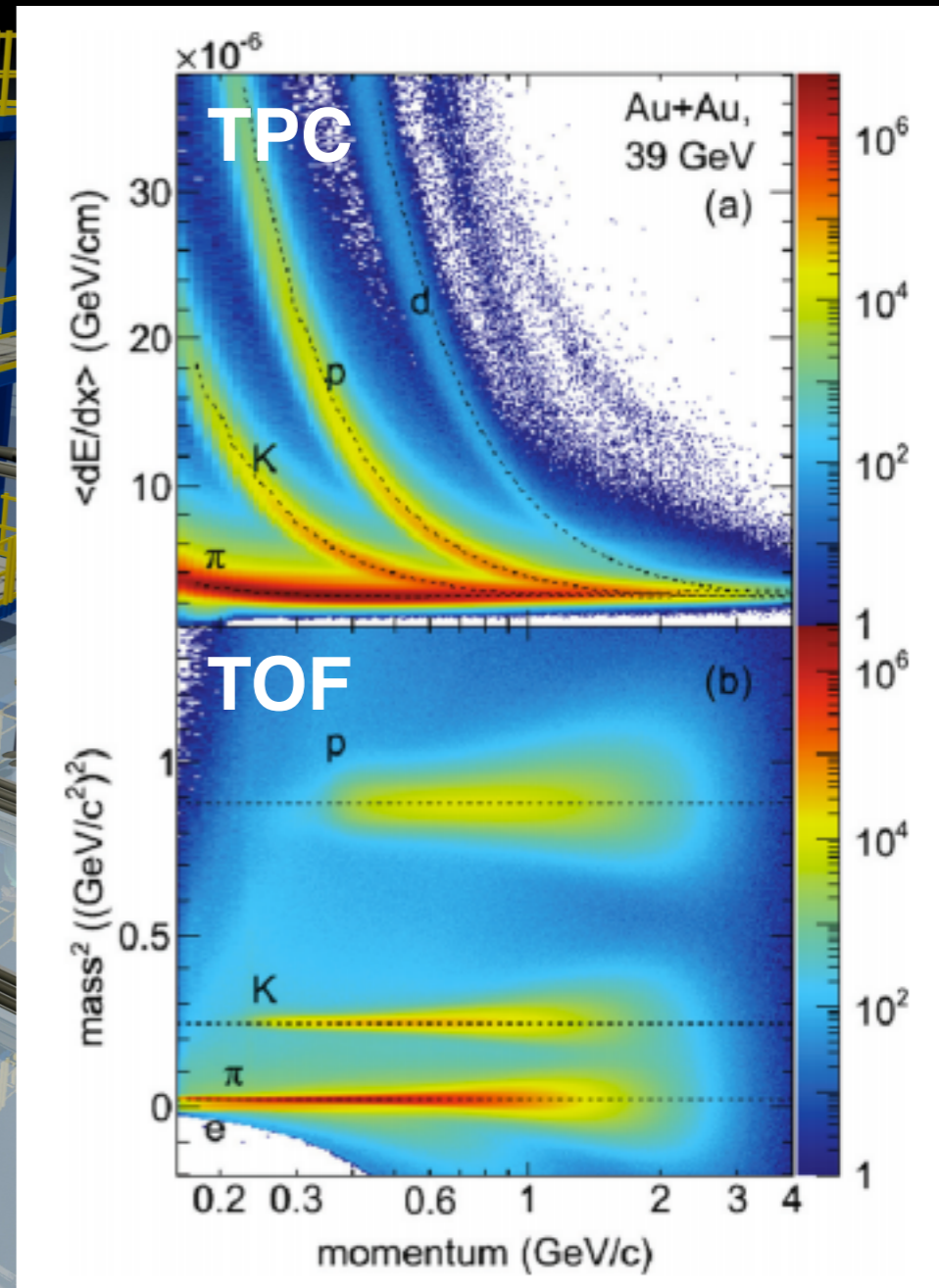

STAR Detector

BBC

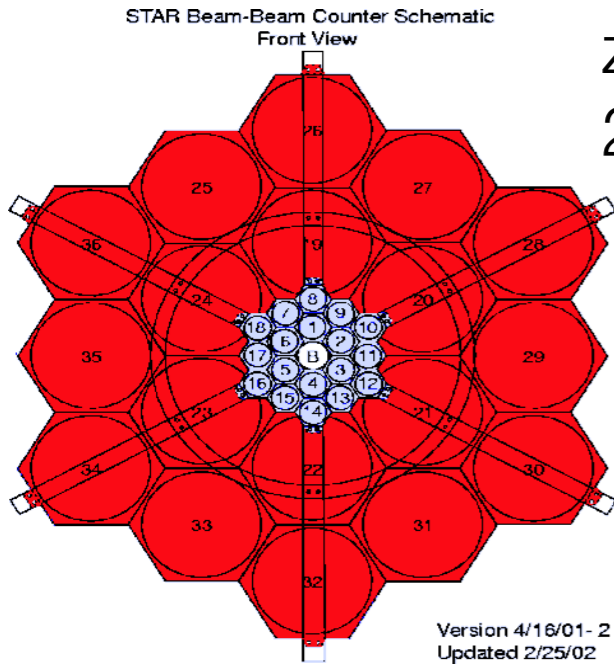

$$z = \pm 3.7 \text{ m}$$

$$2.1 > |\eta| < 5$$

ZDC-SMD

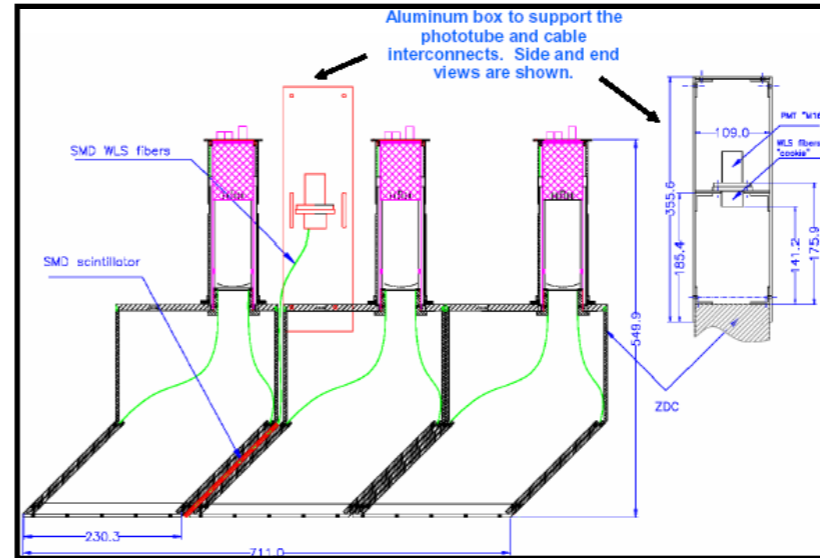

$$z = \pm 18.25 \text{ m}$$

$$\theta < 2 \text{ mrad}$$

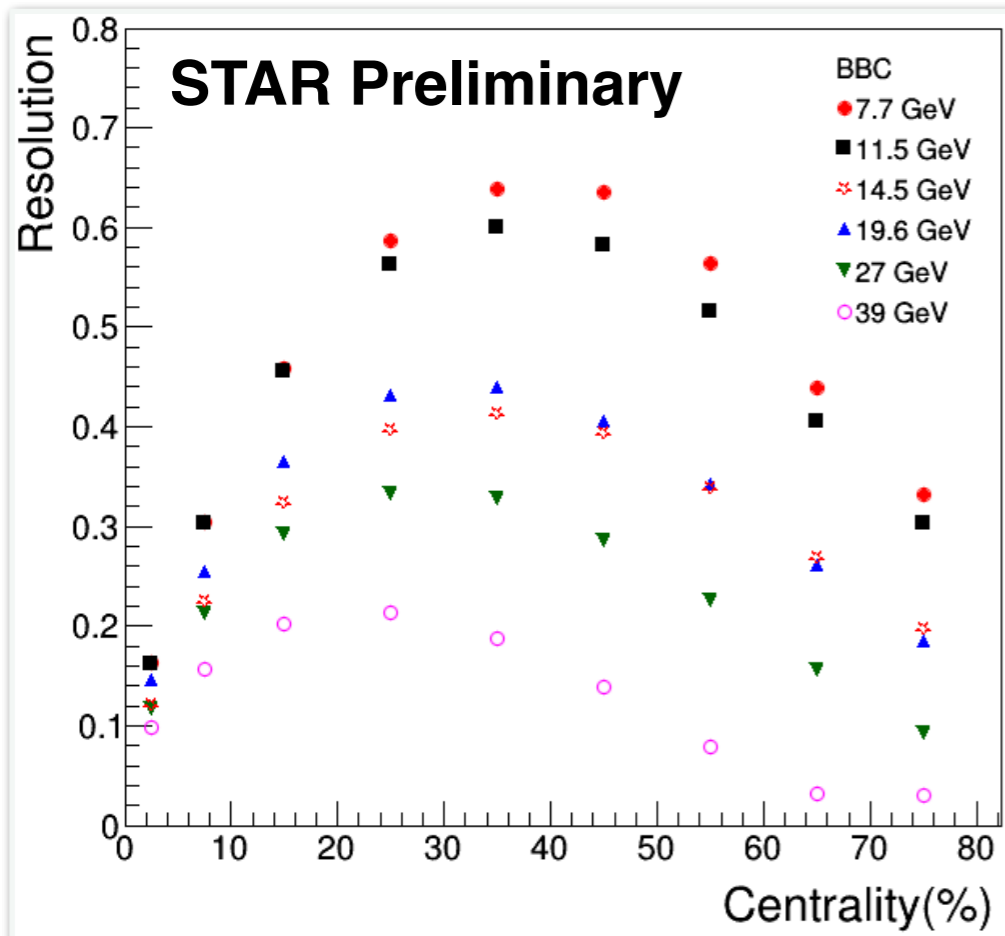

increasing energy

- 1st order event plane estimated using BBC (7.7 - 39 GeV)
ZDC (62.4, 200 GeV)
- v_1 signal significant at forward rapidity
- Large η gap with TPC reduces non-flow effects

Results from AGS

PRL 84, 162301 (2014) (E895 Coll)

PRL 85, 162301 (2014) (E895 Coll)

PRL 86, 162301 (2014) (E895 Coll)

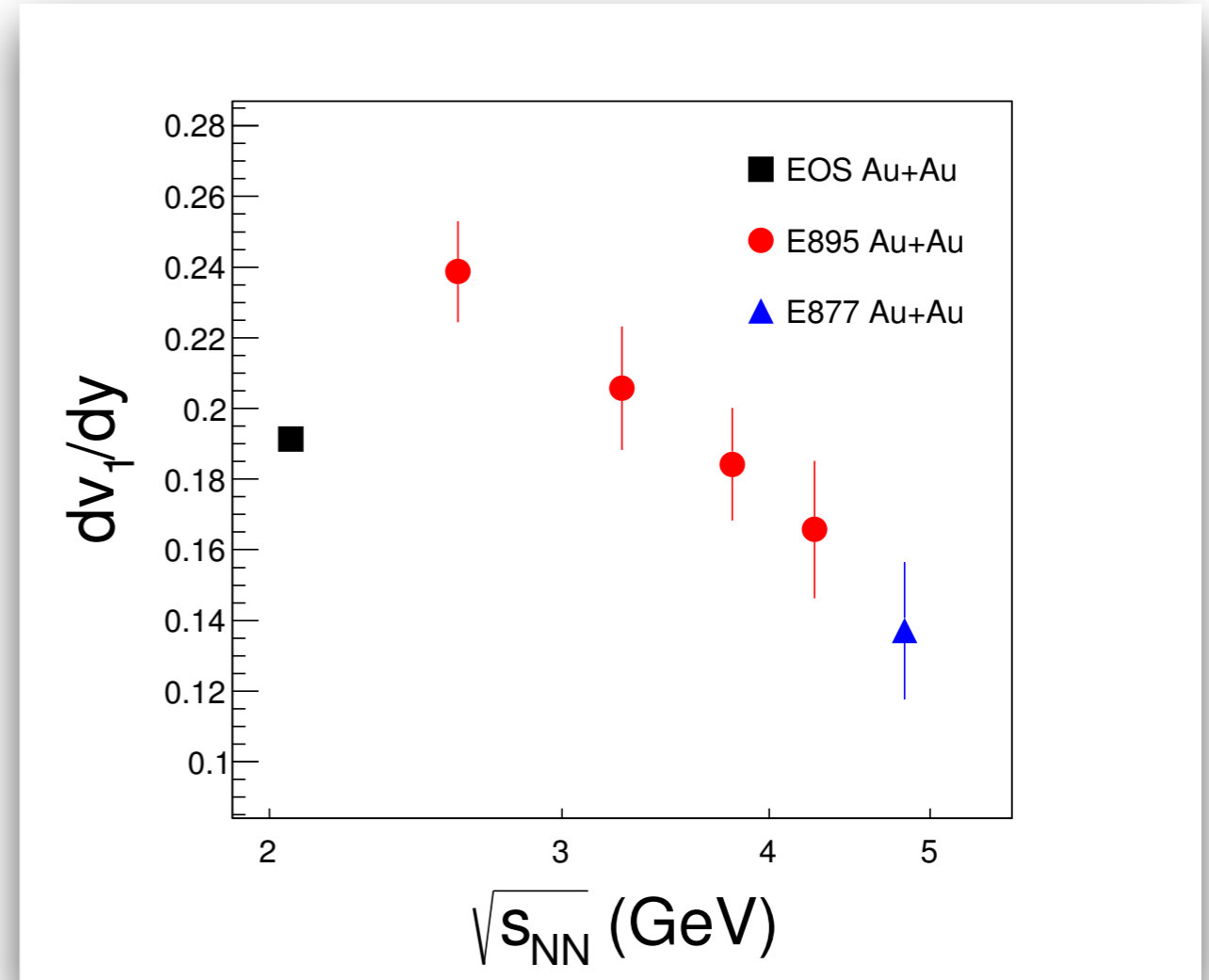
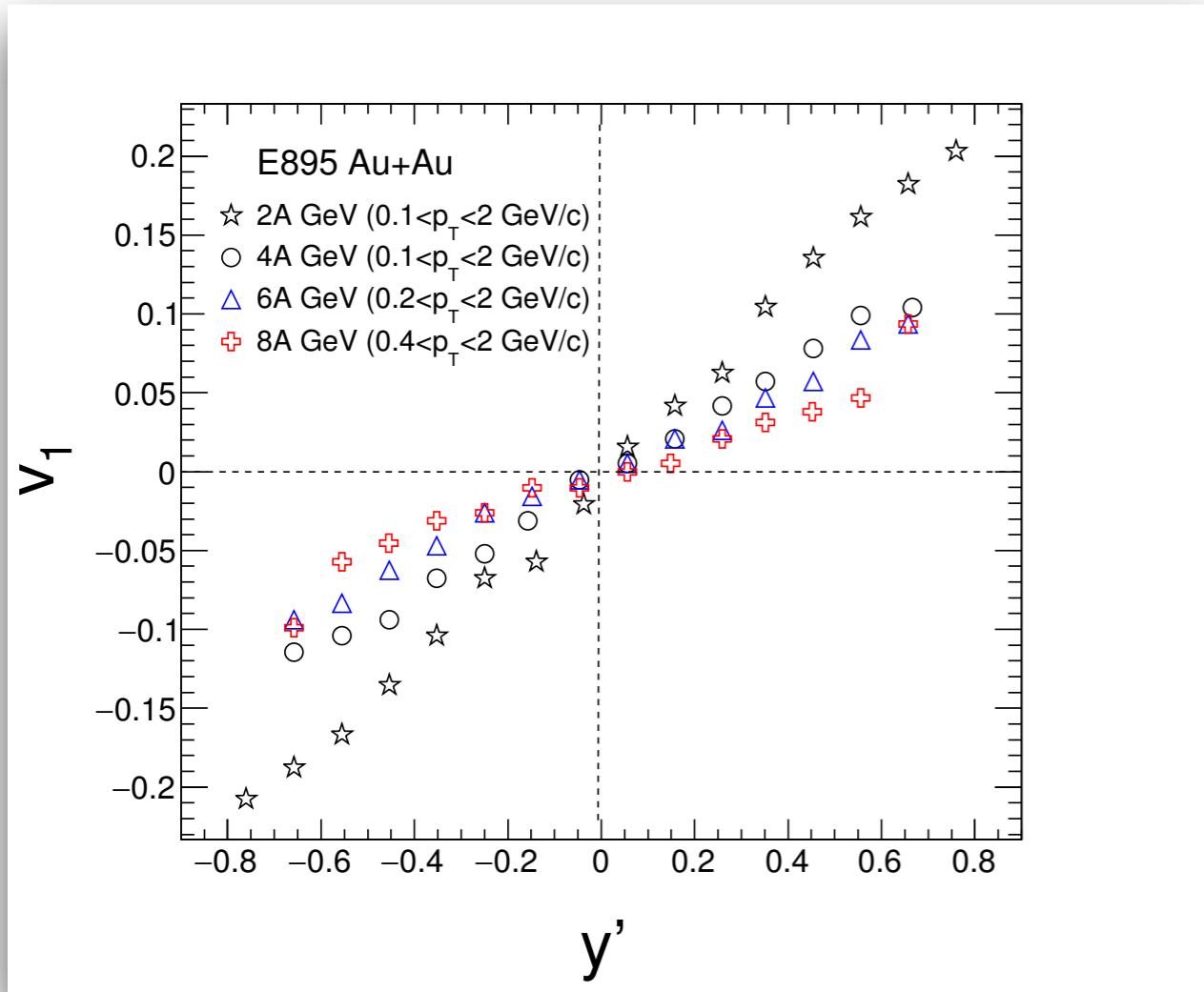

- positive dv_1/dy of protons for all energies
- no dip observed at AGS around $\sqrt{s_{NN}} \sim 3.5$ GeV

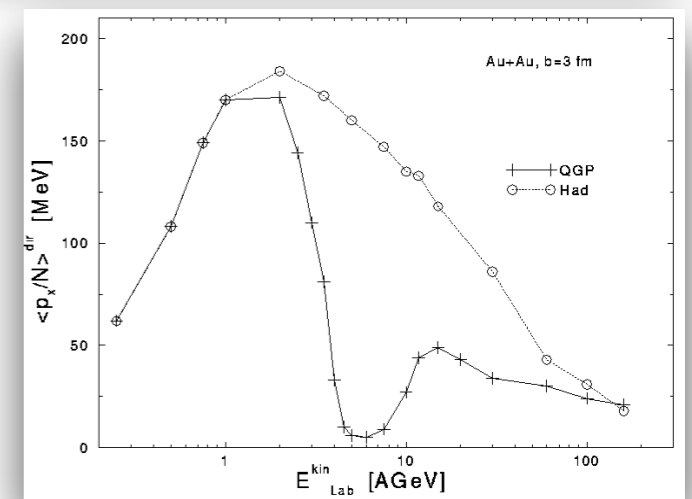

Results from SPS

Phy Rev C 68, 034903 (2003) (NA49 Coll)

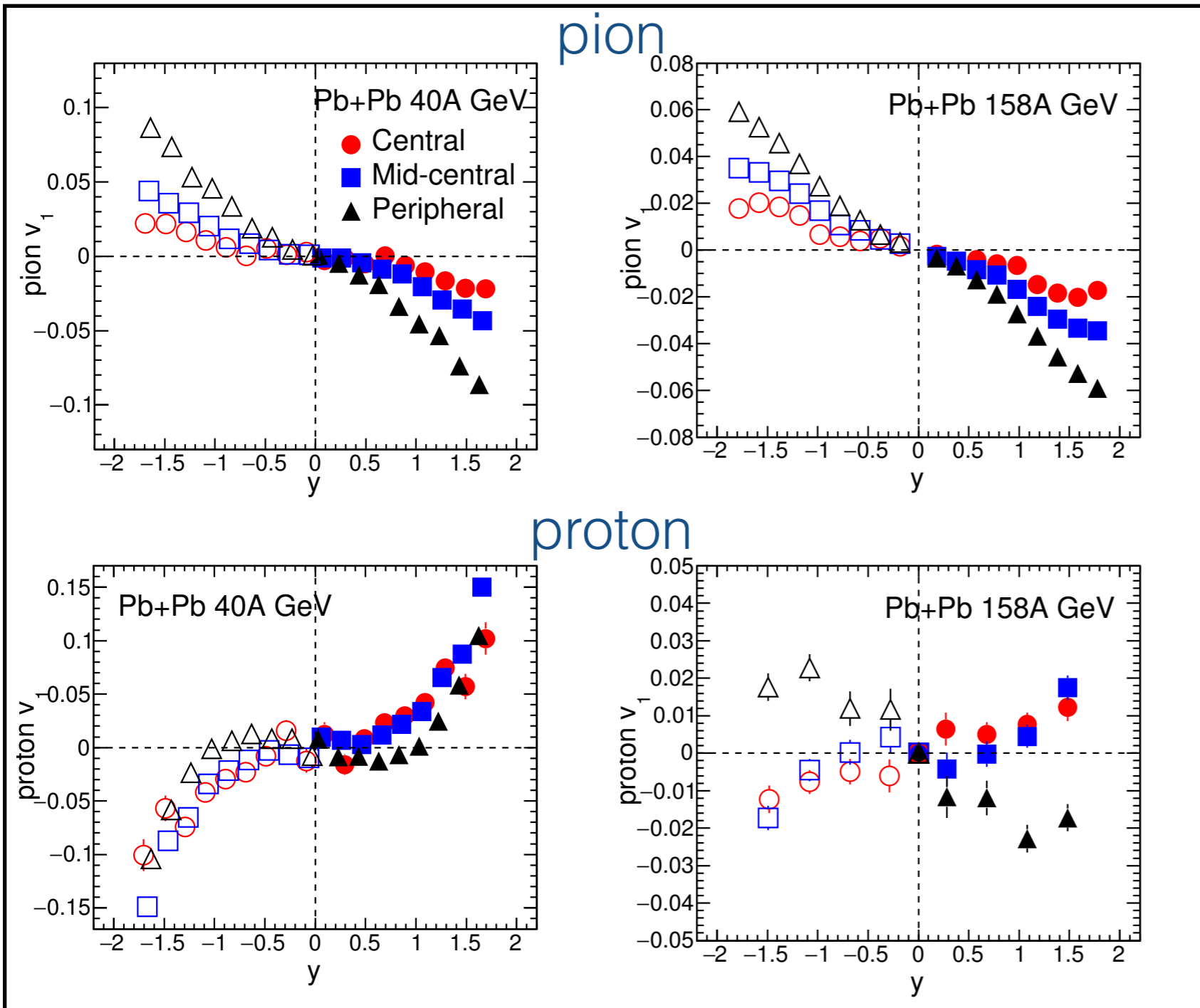

- $(dv_1/dy)_{\text{pion}} \sim \text{negative}$ for 40A, 158A GeV
- $(dv_1/dy)_{\text{proton}} \sim \text{positive}$ 40A GeV, all centrality
- 158A GeV, central/mid central
- $(dv_1/dy)_{\text{proton}} \sim \text{negative}$ 158A GeV, peripheral

Shadowing effect from spectators in peripheral collisions

Results from RHIC

Charged hadron v_1

PRL 108, 162301 (2014) (STAR Coll)

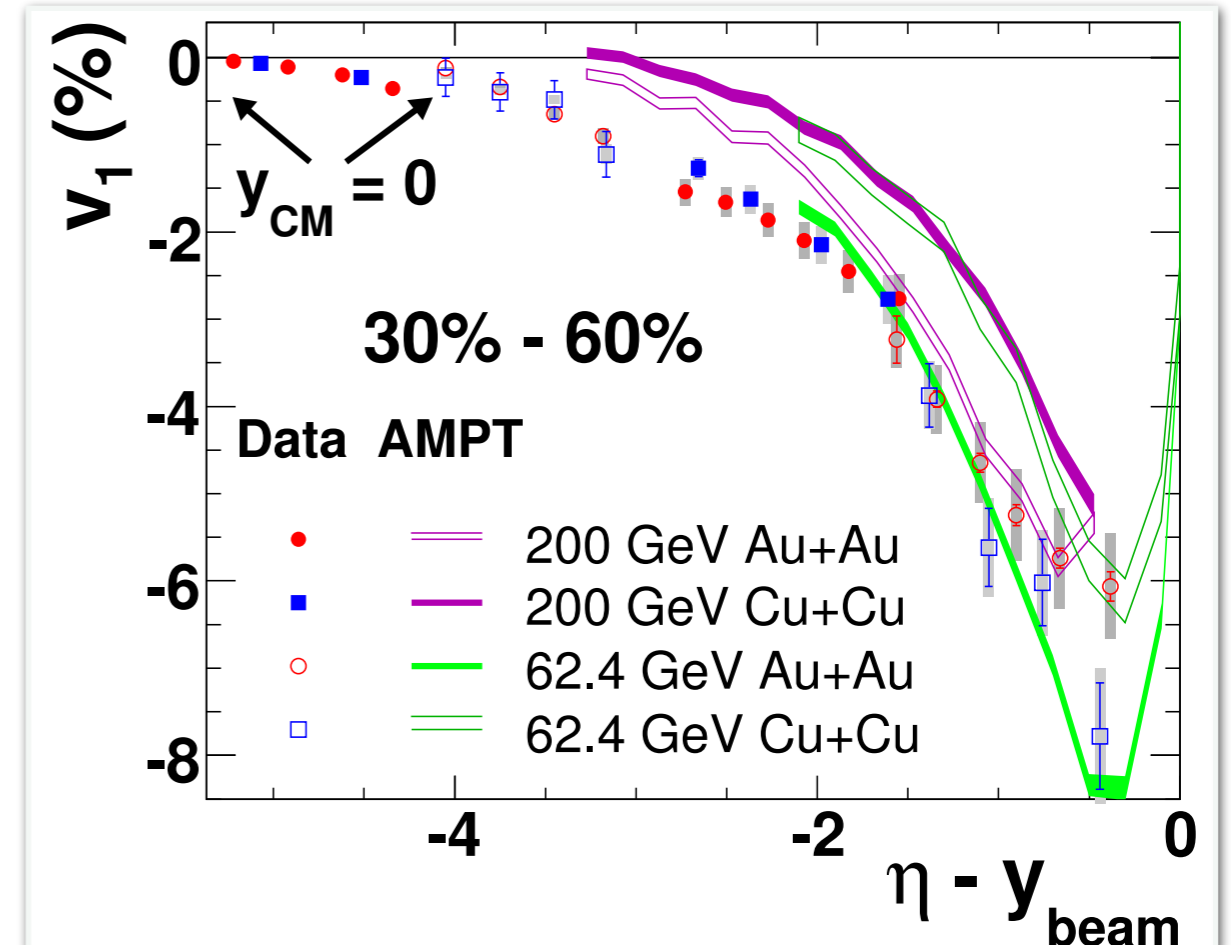
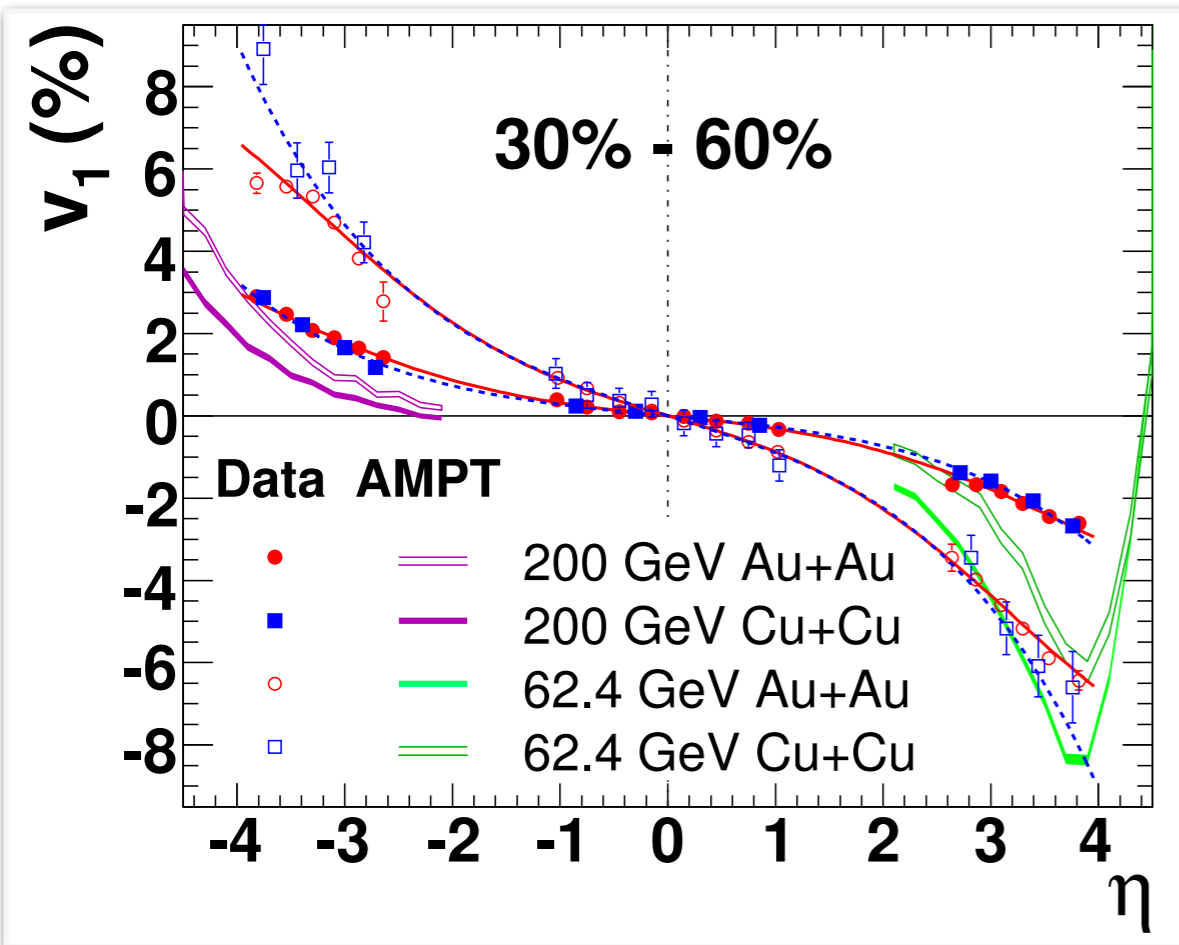

- v_1 is independent of system size (Au+Au \sim Cu+Cu)
- v_1 shows limiting fragmentation behavior

System size behavior can be explained by Hydro+tilted source

P. Bozek et al PRC 81, 054902 (2010)

Energy dependence of proton and pion v_1

PRL 112, 162301 (2014) (STAR Coll)

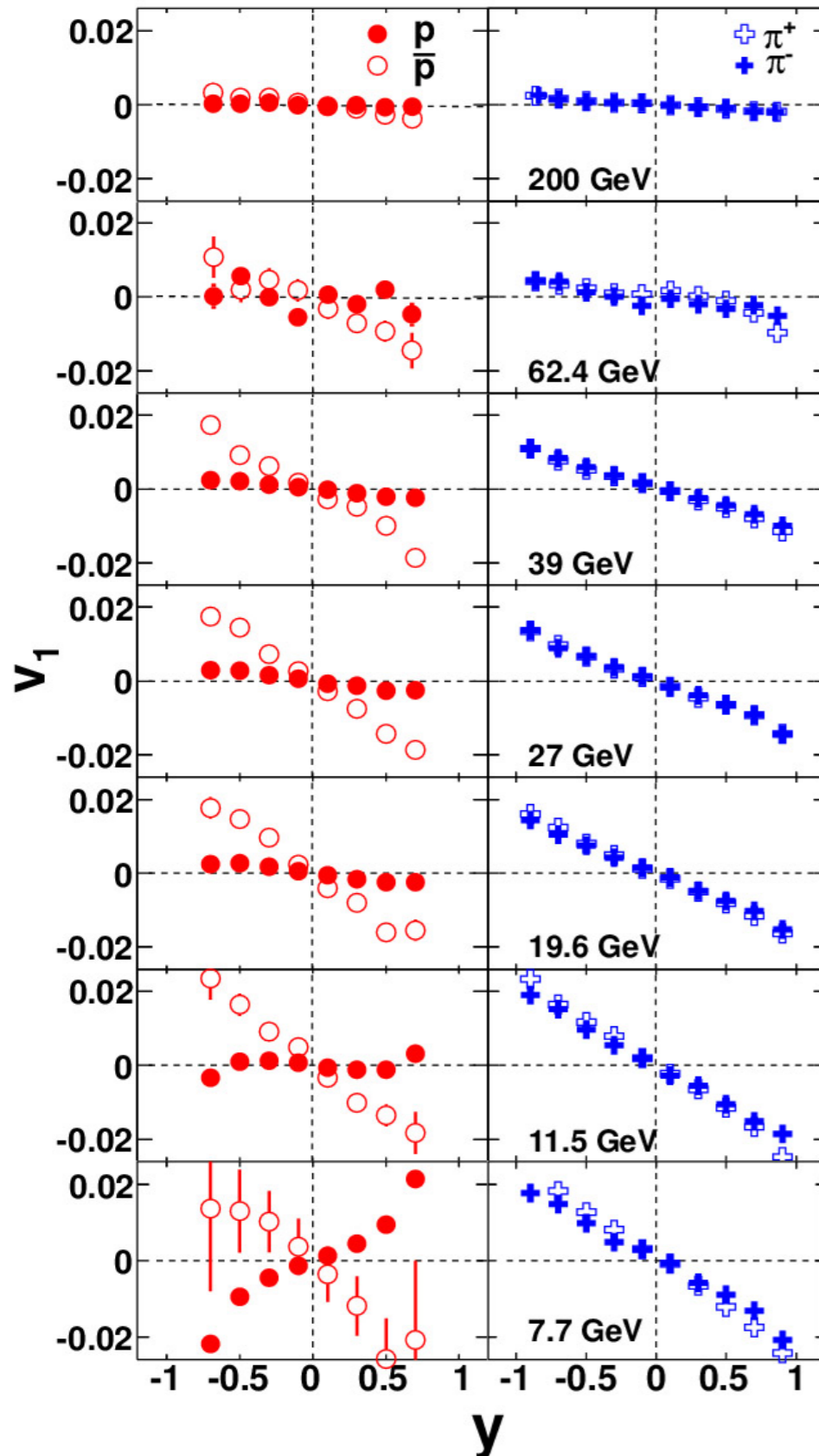

- $(dv_1/dy)_{\text{pion}} \sim \text{negative}$
for $\sqrt{s_{\text{NN}}} = 7.7\text{-}200$ GeV
- $(dv_1/dy)_{\text{proton}} \sim \text{negative}$
 $\sqrt{s_{\text{NN}}} \geq 11.5$ GeV
changes sign at $\sqrt{s_{\text{NN}}} = 7.7$ GeV
- $(dv_1/dy)_{\text{antiproton}} \sim \text{negative}$
for $\sqrt{s_{\text{NN}}} = 7.7\text{-}200$ GeV

v_1 -slope extracted by fitting a cubic function

Energy dependence of proton and pion v_1

PRL 112, 162301 (2014) (STAR Coll)

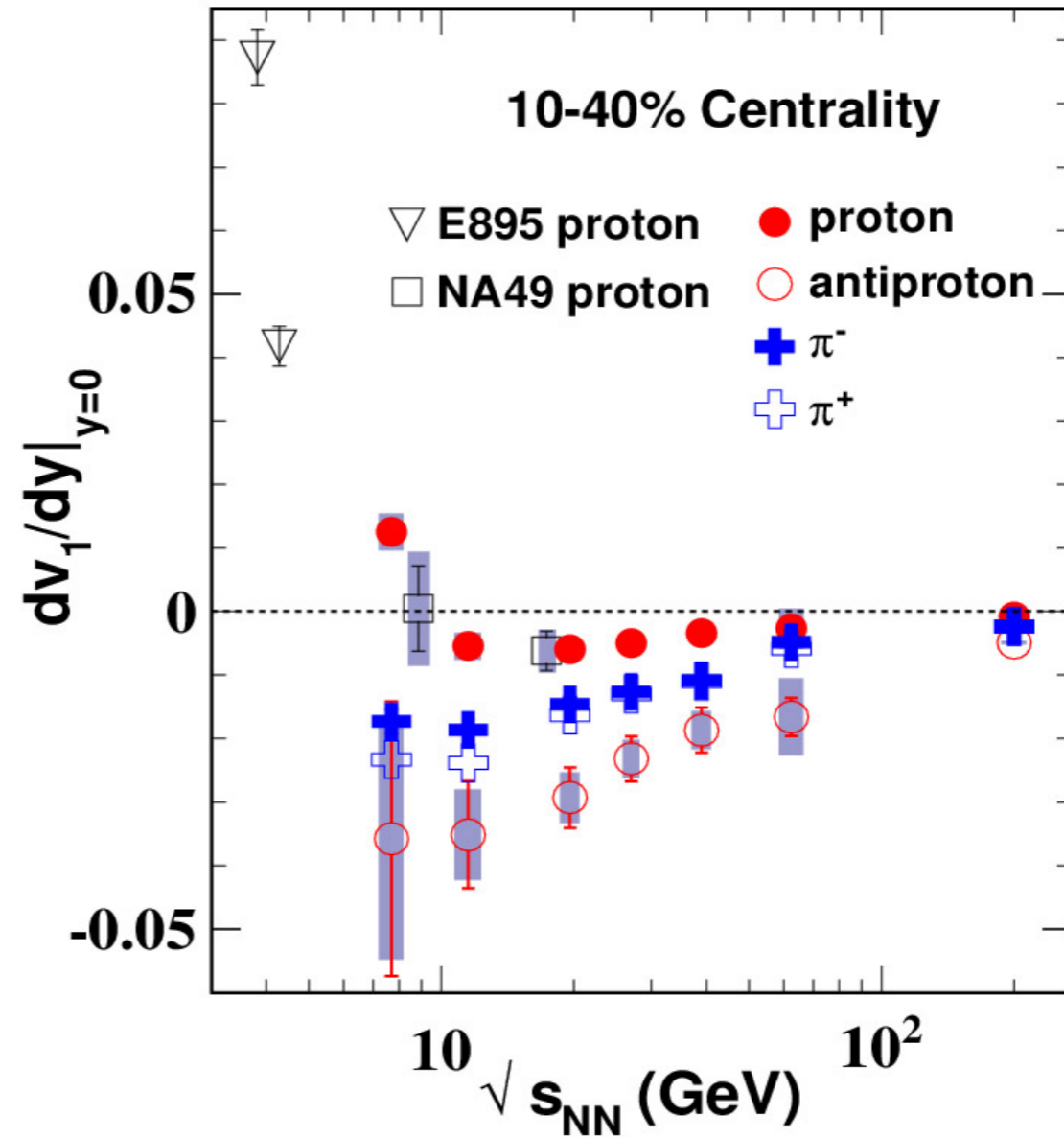
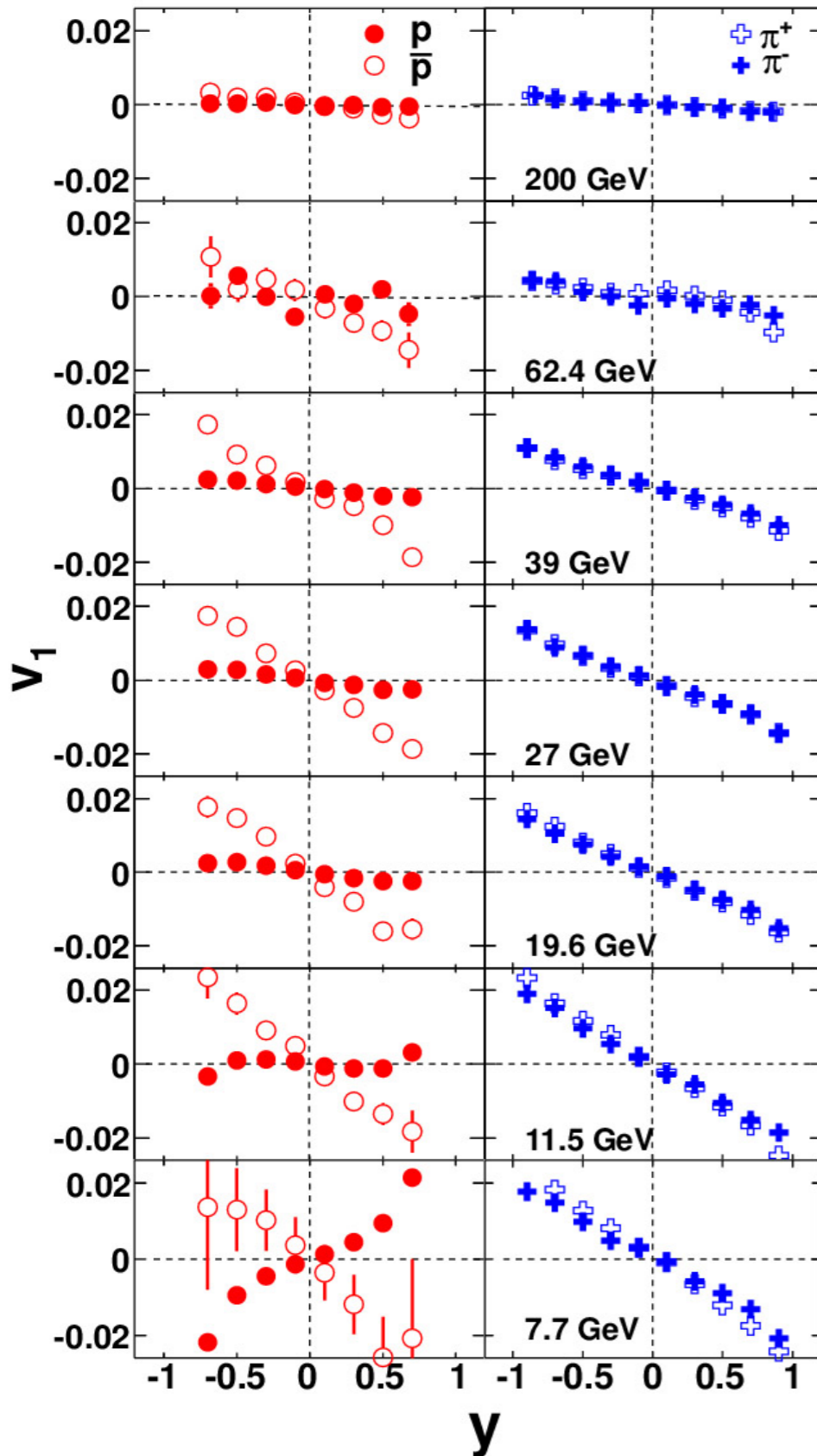

- Trend observed by STAR inline with NA49 and E895 data

Energy dependence of proton and pion $v_1(y)$

PRL 112, 162301 (2014) (STAR Coll)

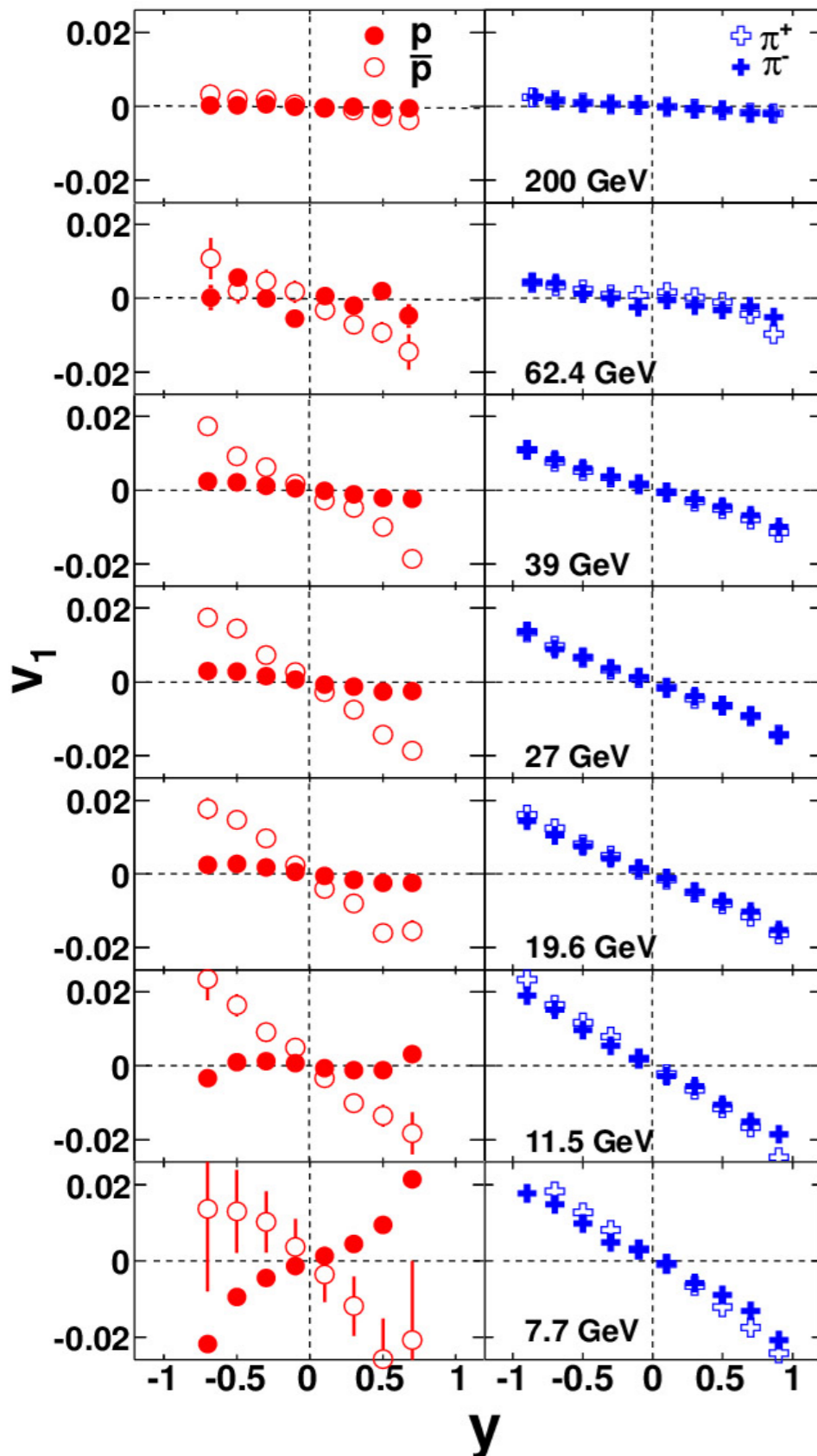

Y. Guo et. al, Phys. Rev. C 86, 044901 (2012)

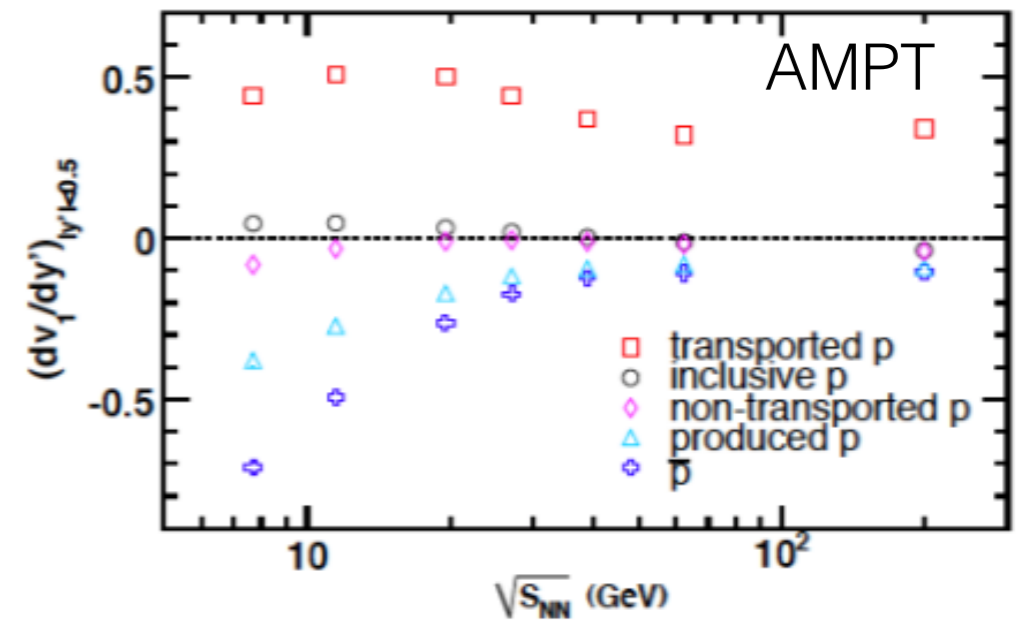

- Observed proton v_1 has contributions from produced and transported quarks

To disentangle these contributions, we define

$$F_p = r_1 F_{\text{anti-p}} + (1-r_1) F_{\text{net-p}}$$

$$F = dv_1/dy, \quad r_1(y) = \text{anti-p}/p$$

proxy for transported protons

Energy dependence dv_1/dy

PRL 112, 162301 (2014) (STAR Coll)

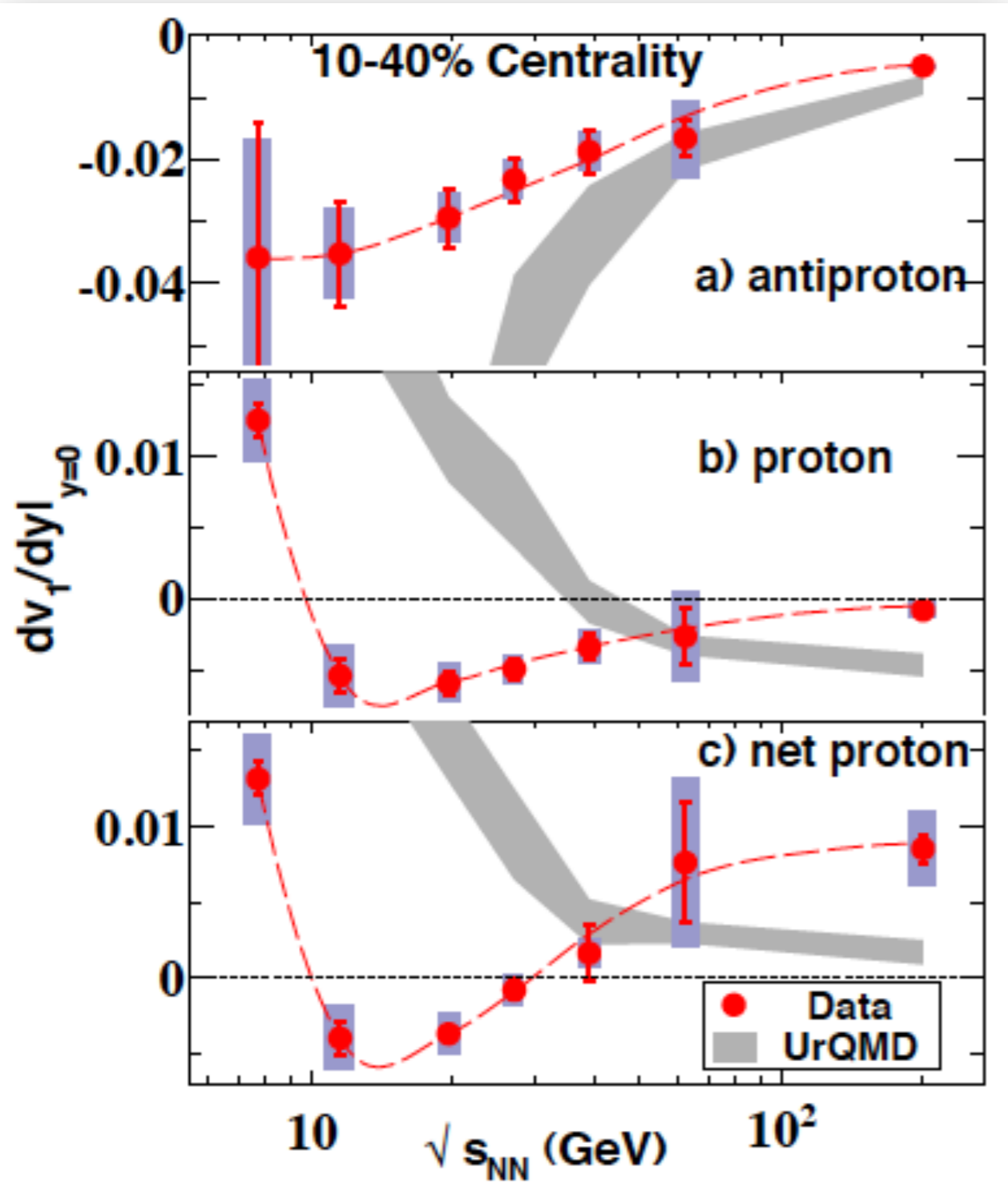

$$F_p = r_1 F_{\text{anti-p}} + (1-r_1) F_{\text{net-p}}$$

$$F = dv_1/dy, \quad r_1(y) = \text{anti-p}/p$$

Energy dependence dv_1/dy

PRL 112, 162301 (2014) (STAR Coll)

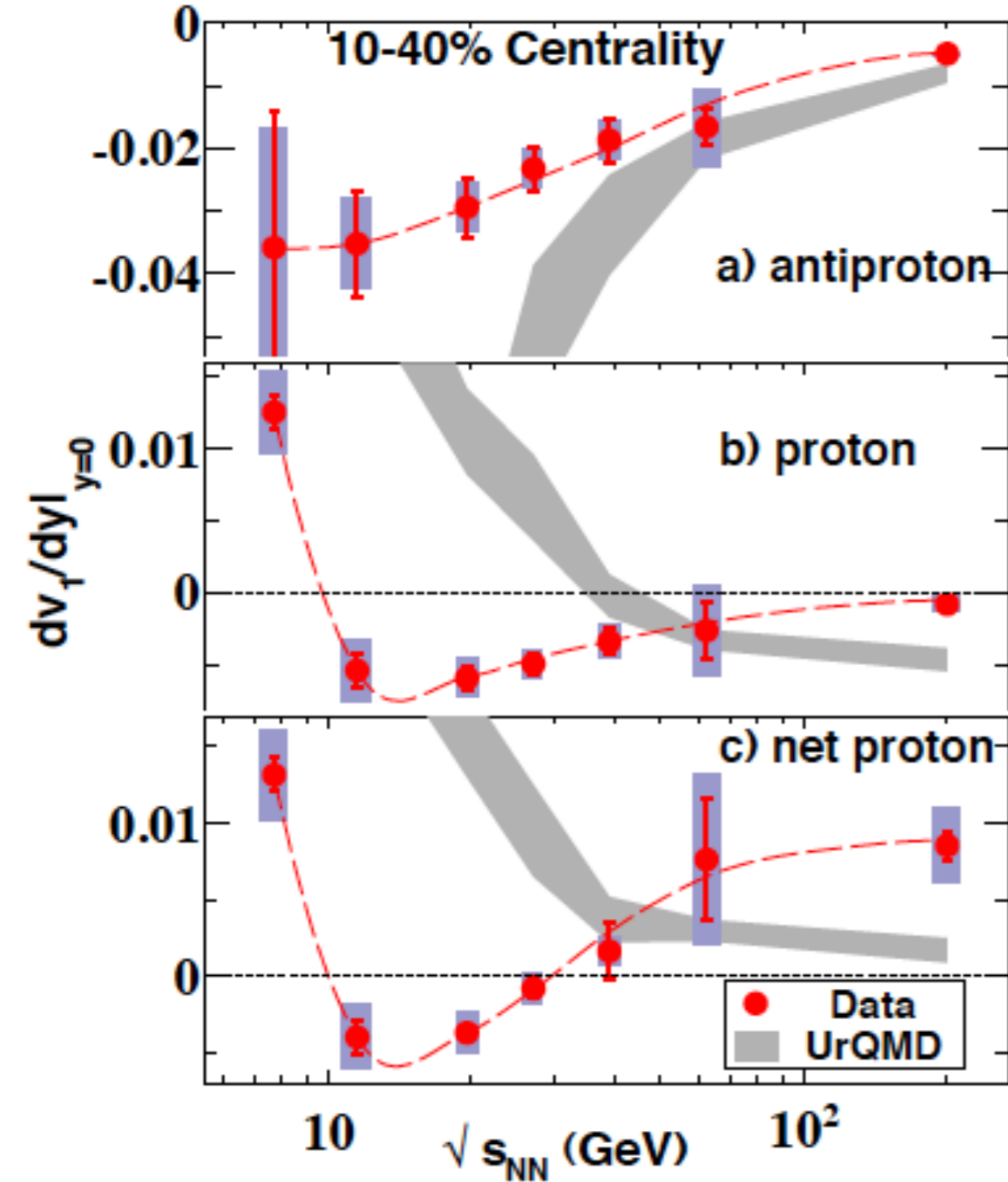

Qualitative resemblance to 3-fluid hydro calculations with 1st order PT

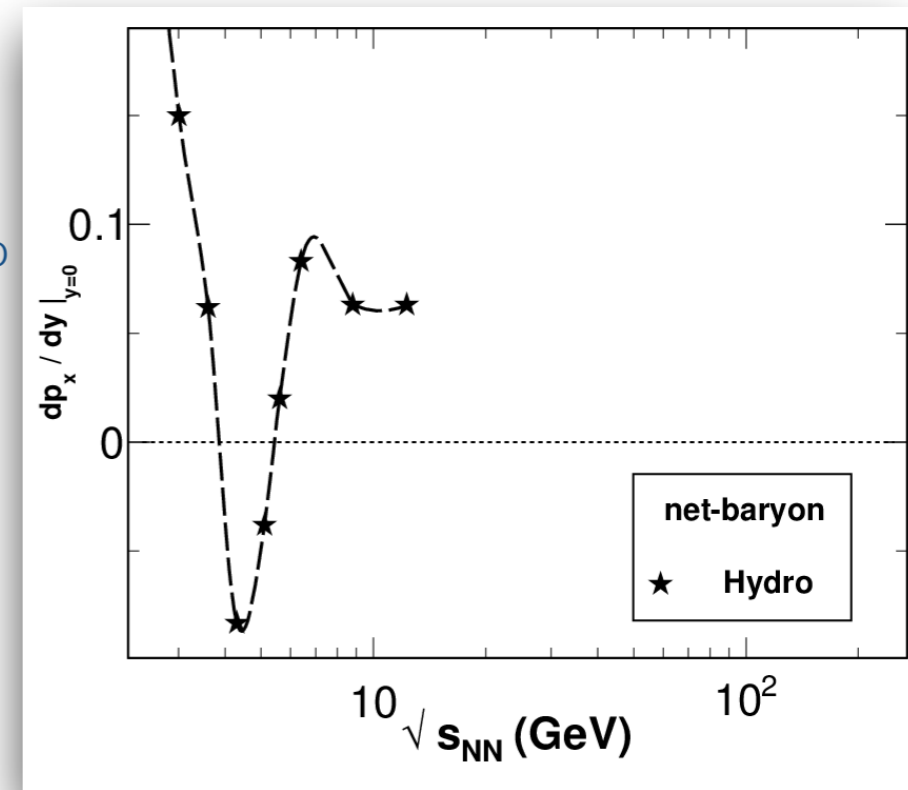

Minimum in net-proton dv_1/dy with double sign change

Softening of EoS (?)

Energy dependence $dv_1/dy|_{y=0}$ with models

Frankfurt hybrid: J. Steinheimer et al., *PRC* **89**, 054913 (2014)

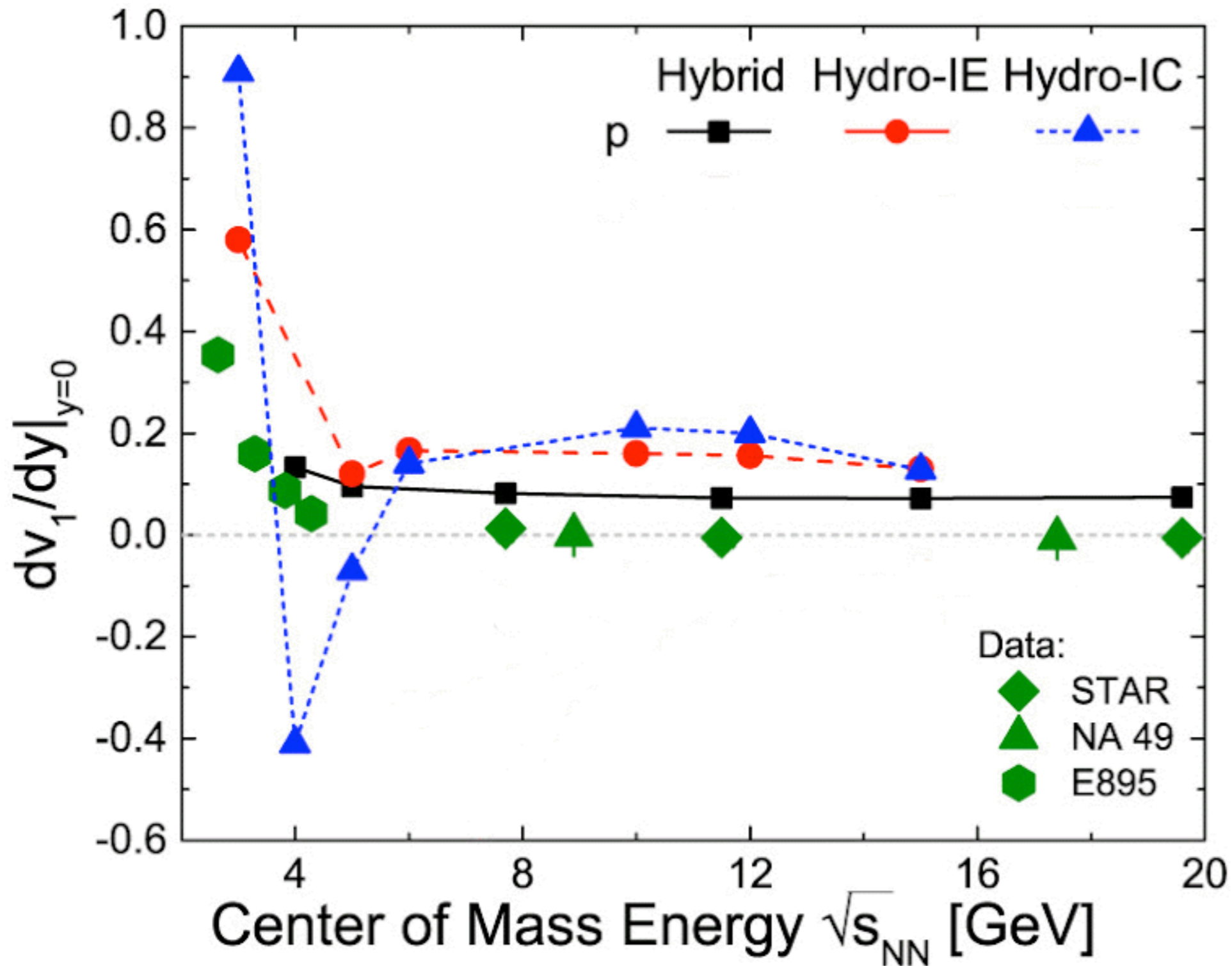

Energy dependence $dv_1/dy|_{y=0}$ with models

Frankfurt hybrid: J. Steinheimer et al., PRC 89, 054913 (2014)

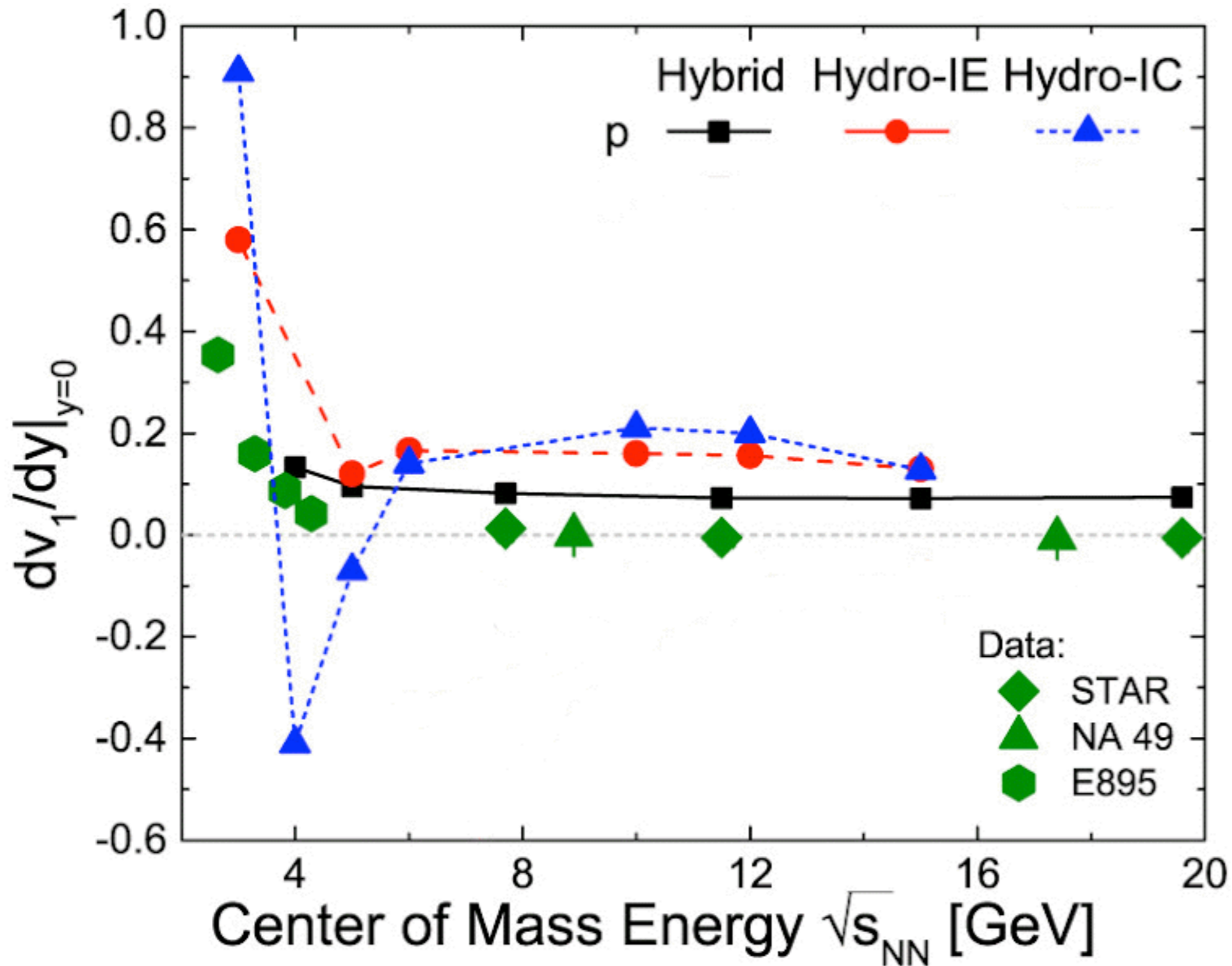

“All models severely underestimate the data”

Energy dependence dv_1/dy with models

3 FD: Y. Ivanov et al., PRC 91, 024915 (2015)

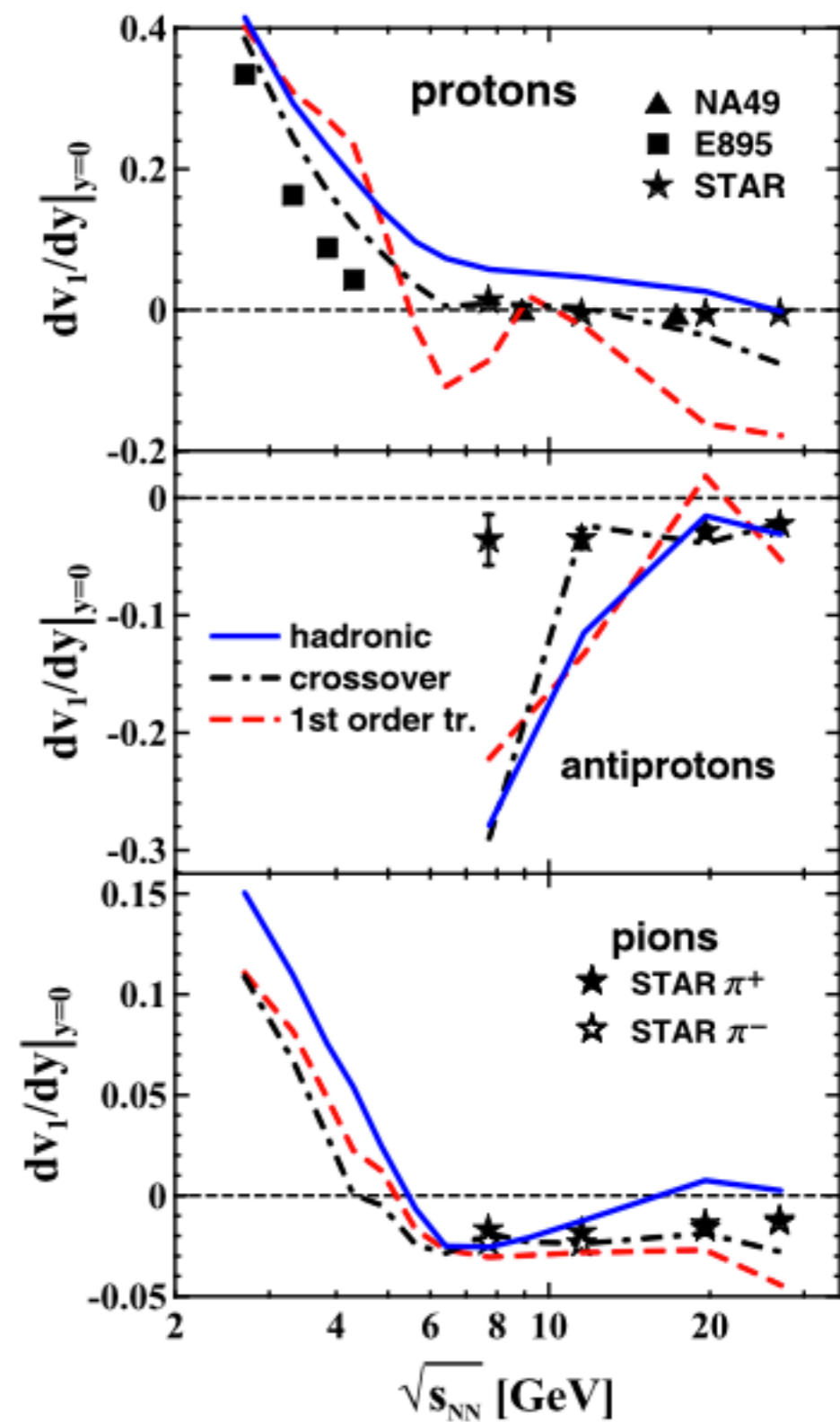
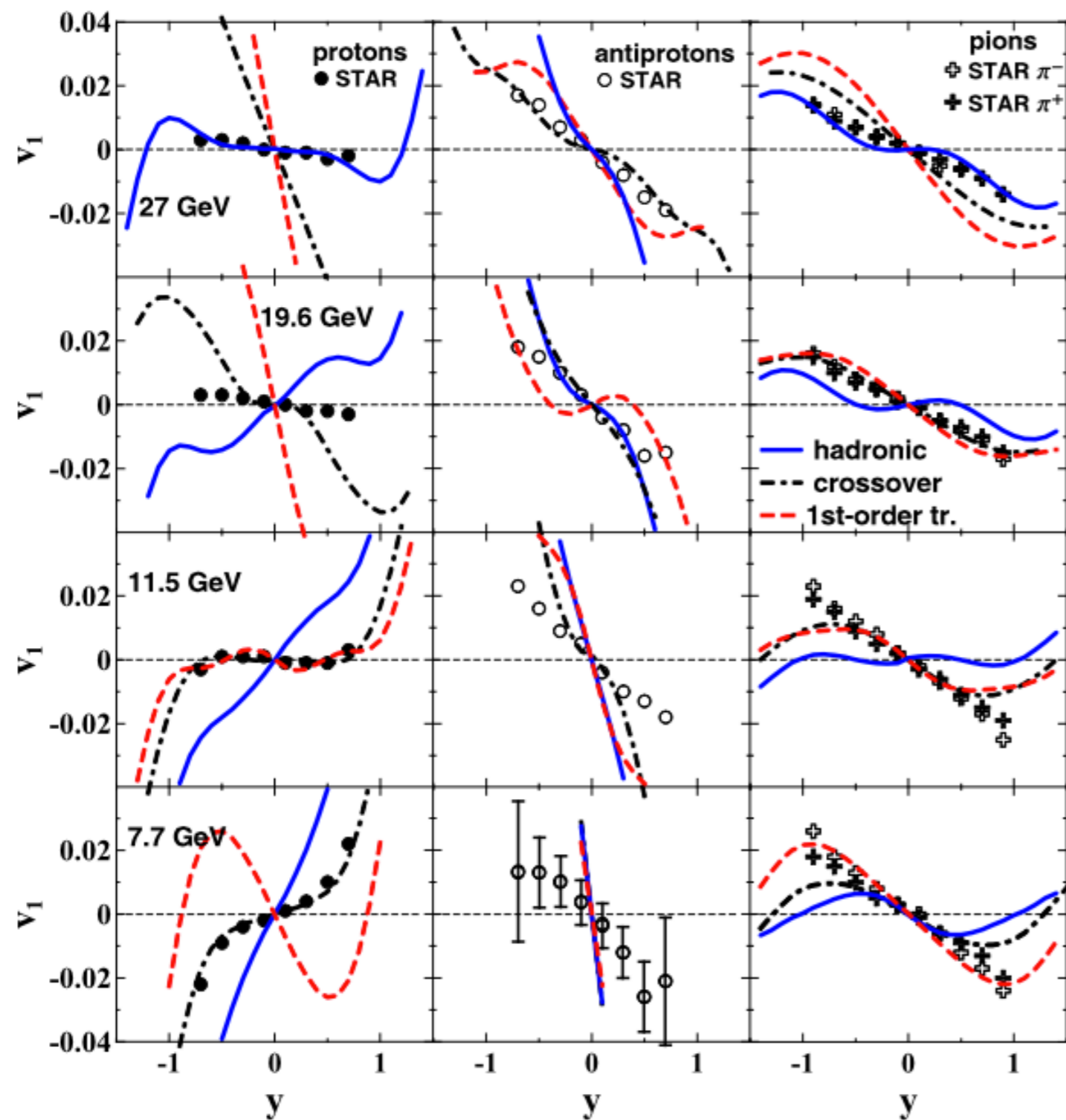

Energy dependence dv_1/dy with models

3 FD: Y. Ivanov et al., PRC 91, 024915 (2015)

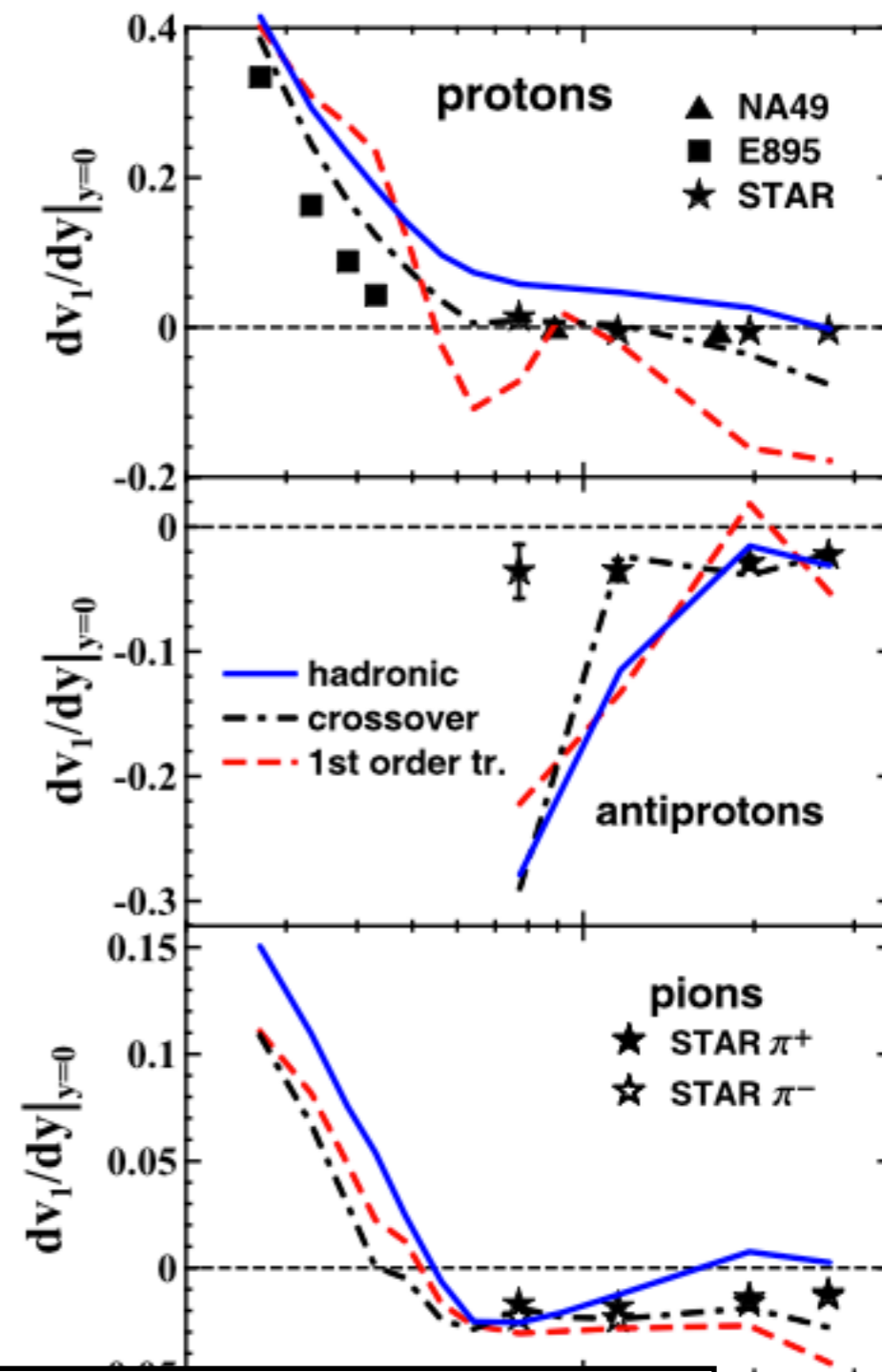
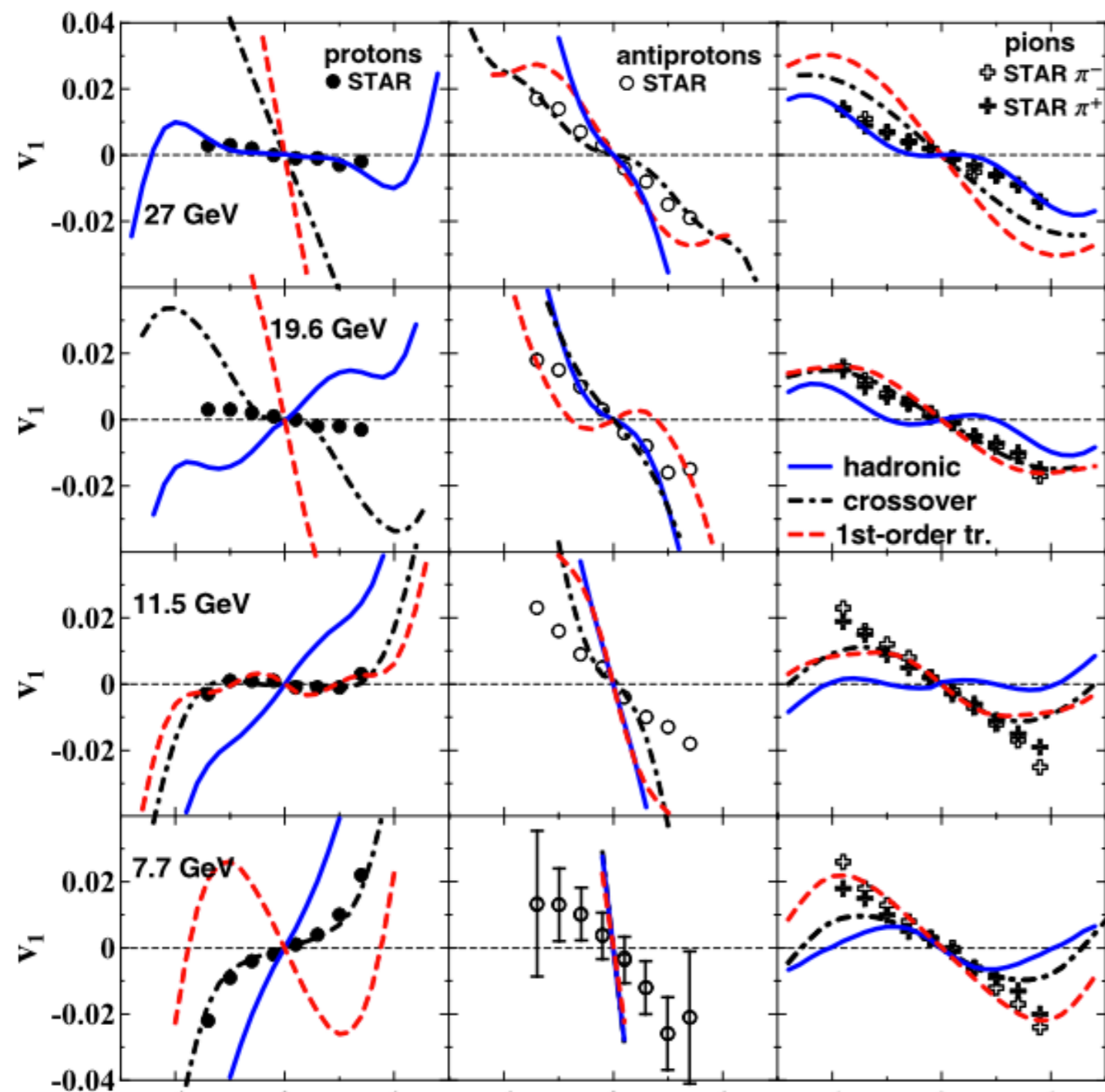

“However, predictions of the crossover and first-order-transition scenarios looked very similar so far. Only a slight preference could be given to the crossover EoS ... best overall reproduction of the STAR data is achieved with the crossover EoS.”

20

Energy dependence dv_1/dy with models

PHSD: V. Konchakovski et al., *PRC* **90**, 014903 (2014)

HSD: W. Cassing et al, arXiv: 1408.4313

UrQMD: S. Bass et al, *Prog. Part. Nucl. Phys* **41**, 255, (1998)

JAM: Y. Nara et al., arxiv: 1601.07692

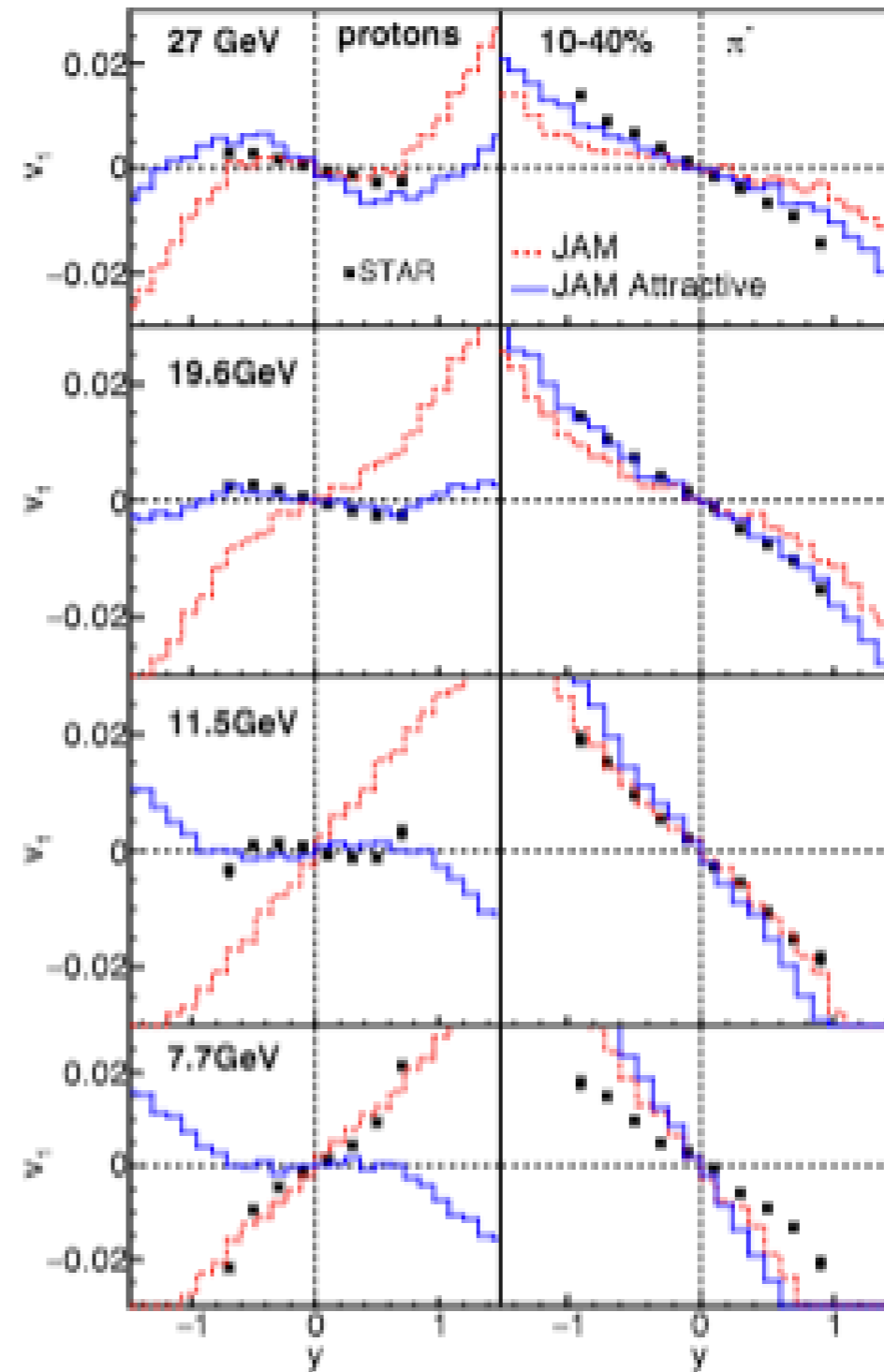
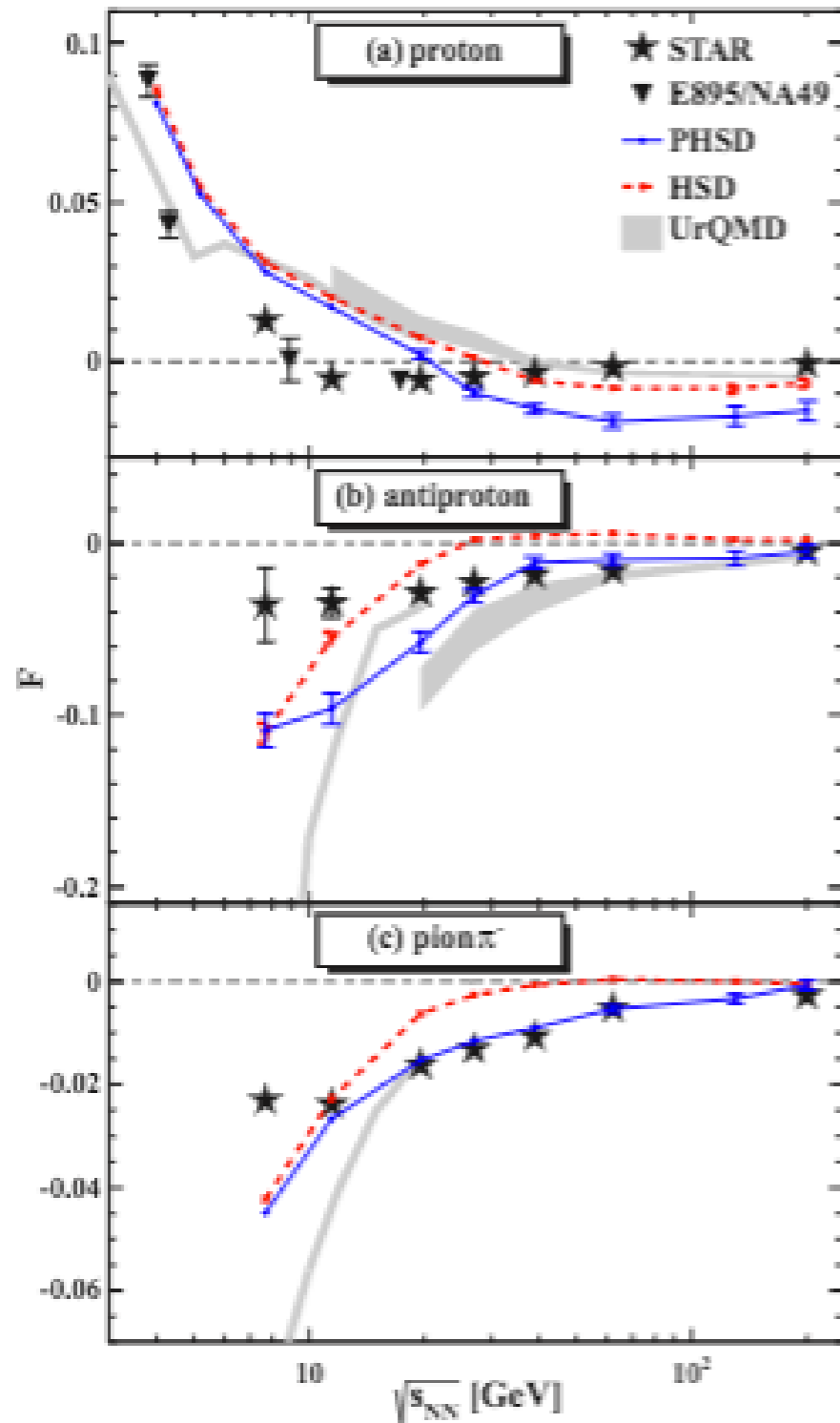

Energy dependence dv_1/dy with models

PHSD: V. Konchakovski et al., *PRC* **90**, 014903 (2014)

HSD: W. Cassing et al, arXiv: 1408.4313

UrQMD: S. Bass et al, *Prog. Part. Nucl. Phys* **41**, 255, (1998)

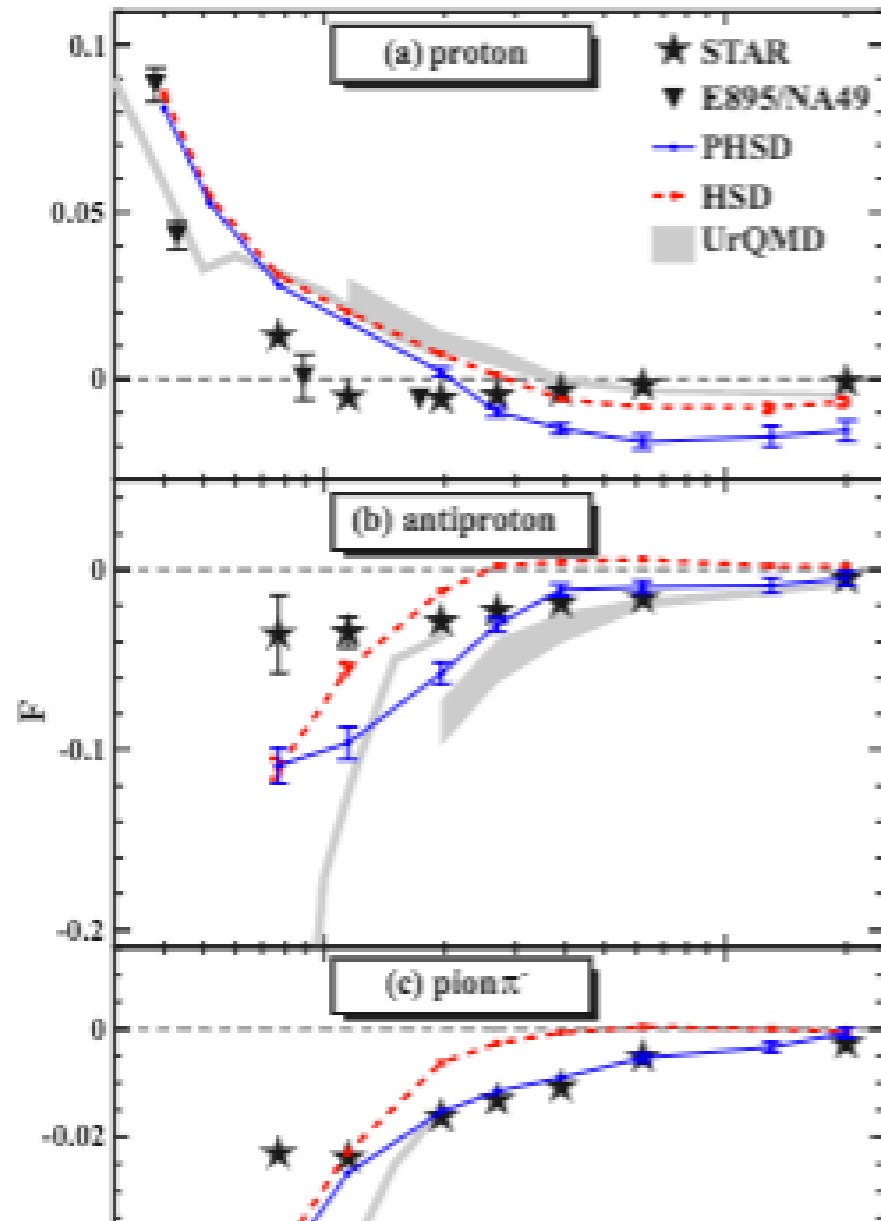

“Still sizable discrepancies with experimental measurements in the directed flow Our flow analysis shows no indication of a first-order transition.”

JAM: Y. Nara et al., arxiv: 1601.07692

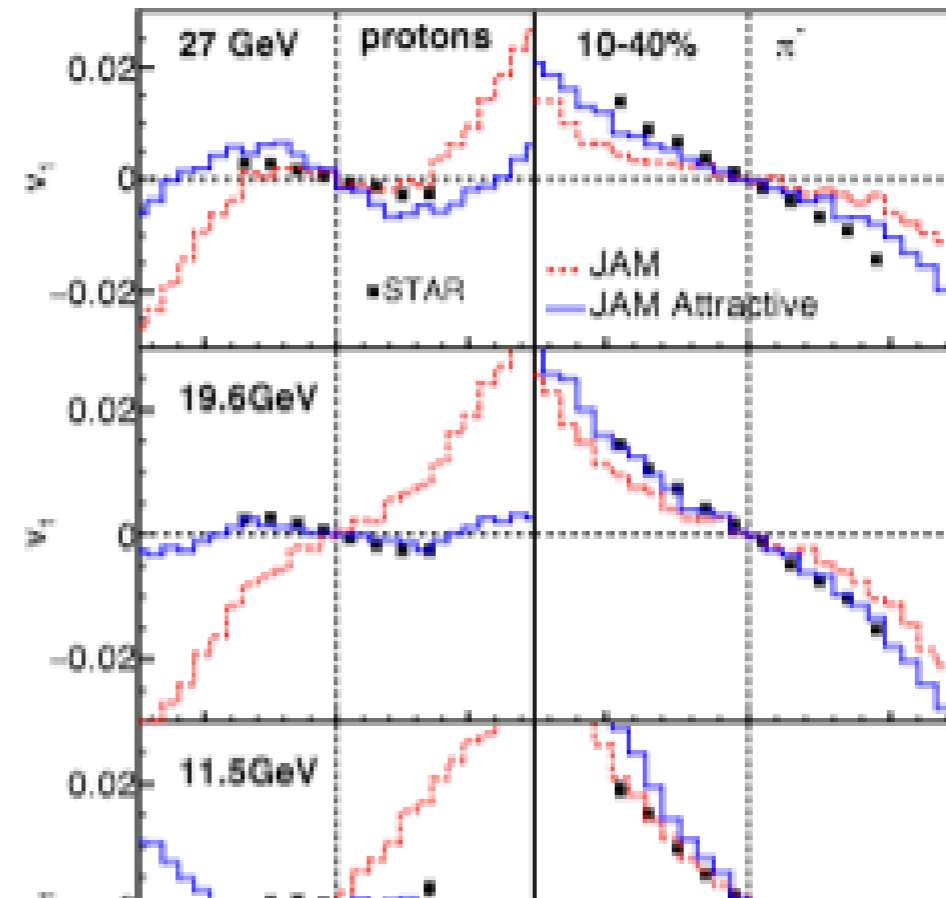

“More detailed systematic studies are needed by using a fully baryon density dependent EoS, in order to draw a conclusion that minimum of dv_1/dy is a result of the softening of the EoS which may be caused by a first-order phase transition.”

Energy dependence dv_1/dy with models

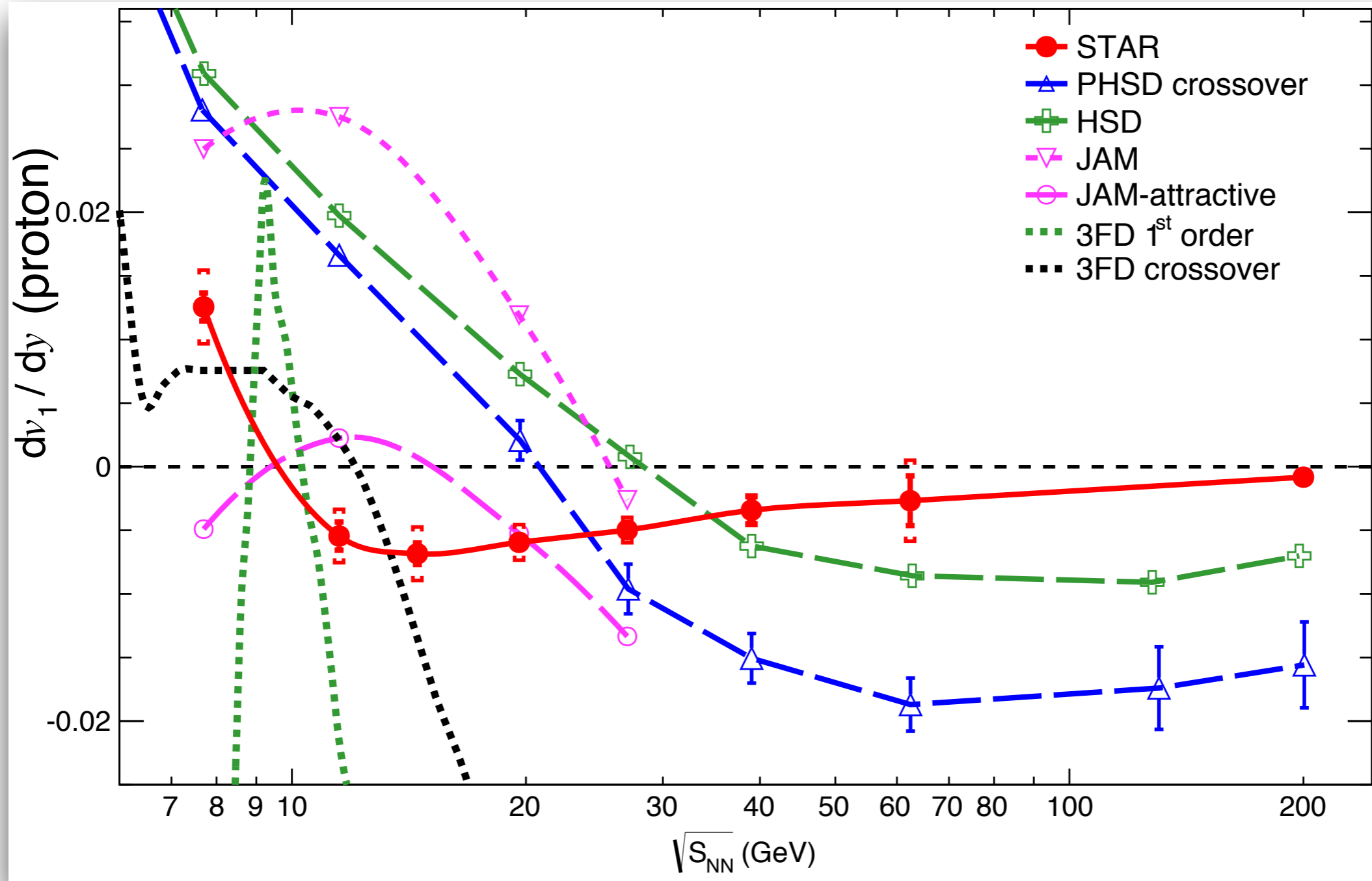

- None of the models explains the data
- Systematics associated with the models is quite large

Energy dependence dv_1/dy with models

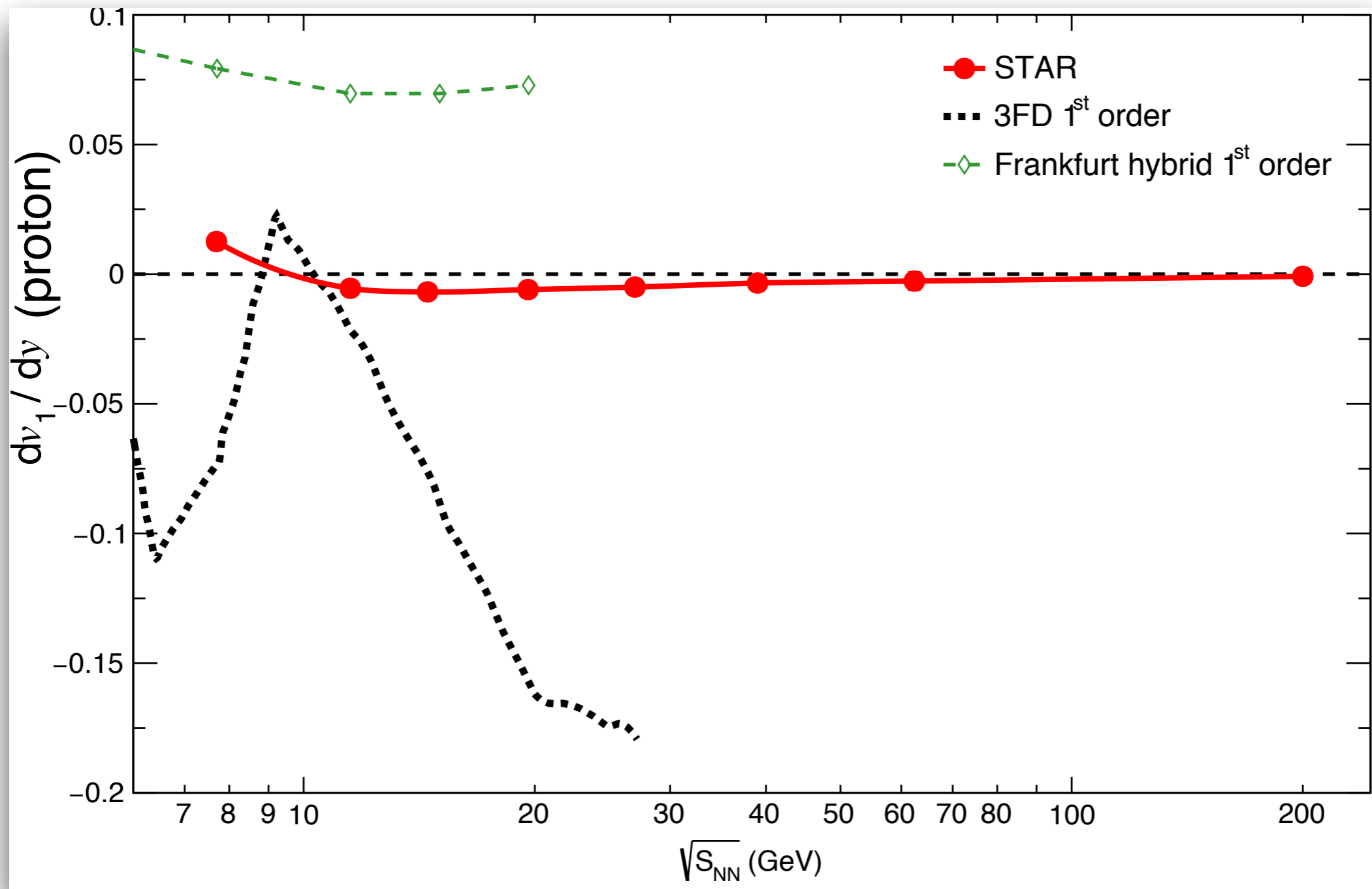

- None of the models explains the data
- Systematics associated with the models is quite large (~ 2 orders of magnitude bigger than experimental errors!)

Energy dependence dv_1/dy with models

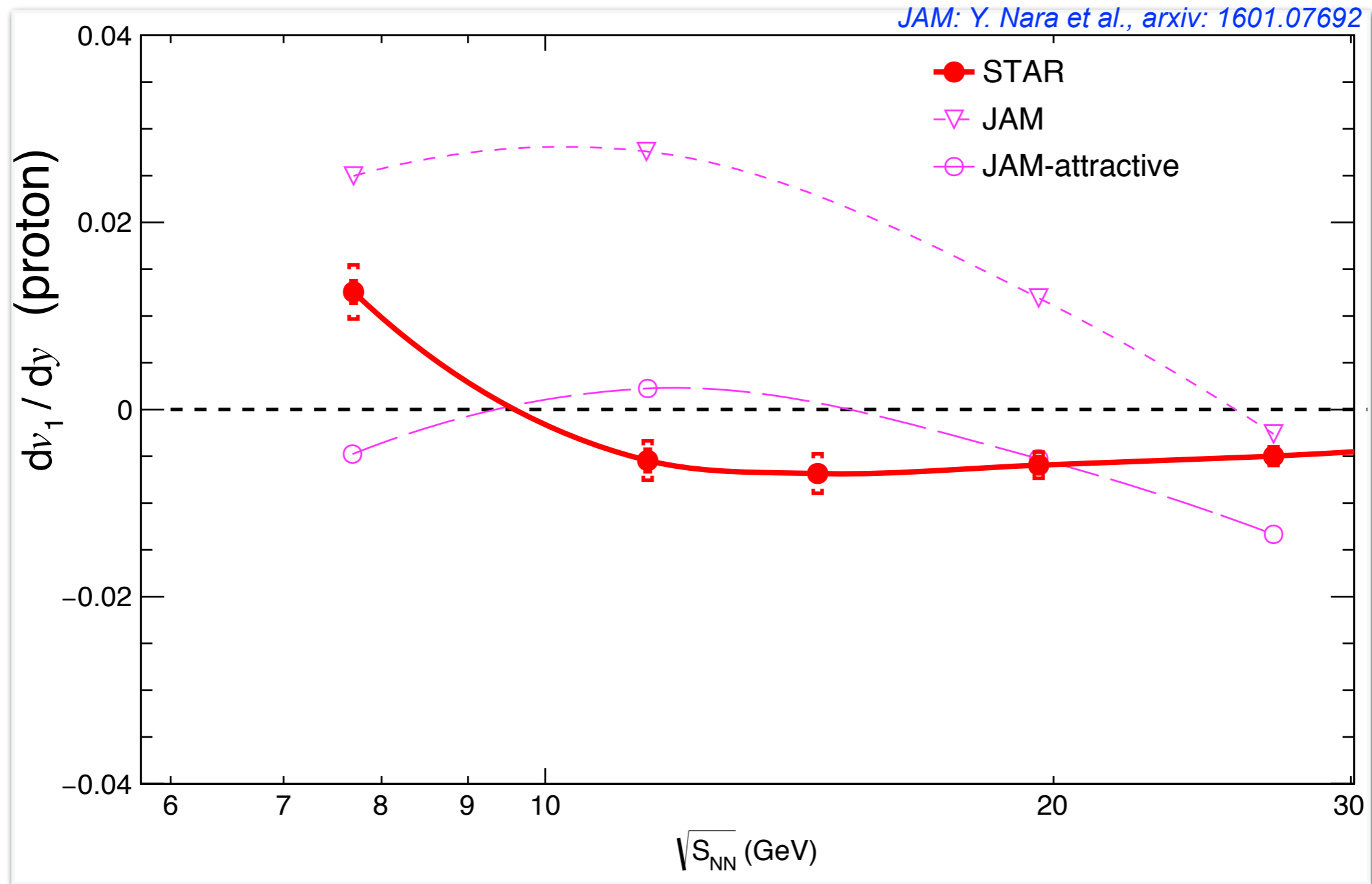

- Standard JAM: Close to data at 7.7 GeV (hadronic description)
Overestimate data at 11.5 and 19.6 GeV
- JAM attractive: Close to data at 11.5 and 19.6 GeV

Energy dependence dv_1/dy with models

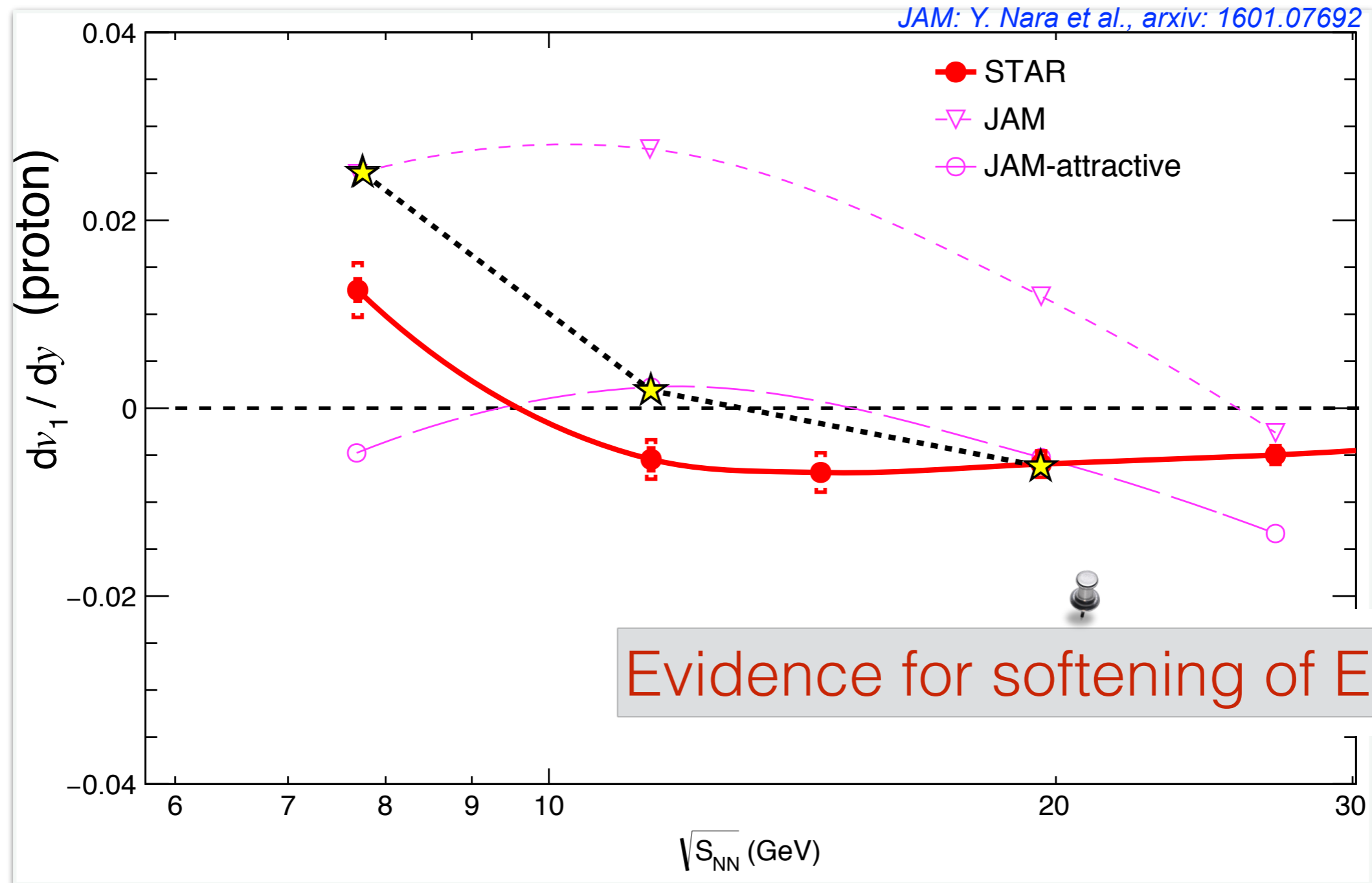

- Standard JAM: Close to data at 7.7 GeV (hadronic description)
Overestimate data at 11.5 and 19.6 GeV
- JAM attractive: Close to data at 11.5 and 19.6 GeV

Energy dependence dv_1/dy with models

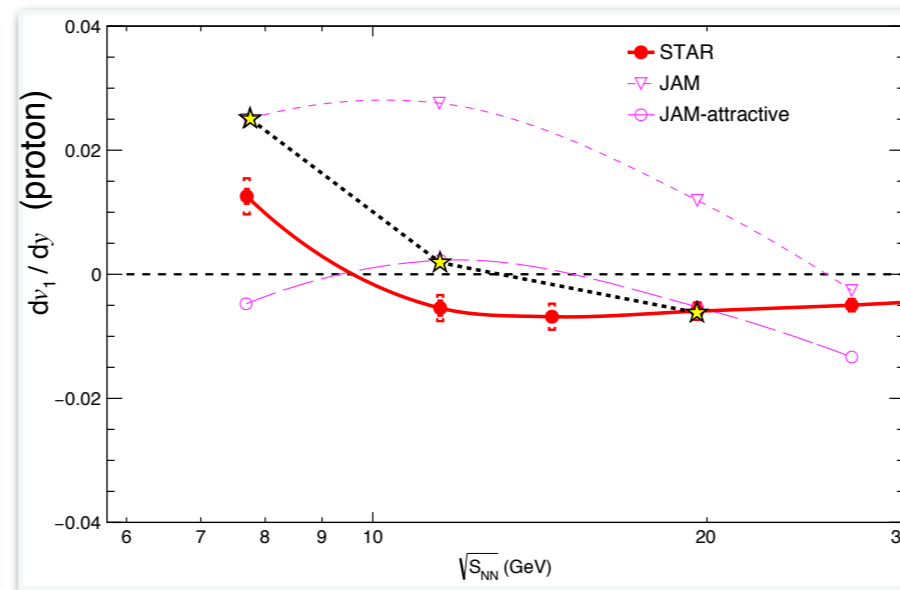
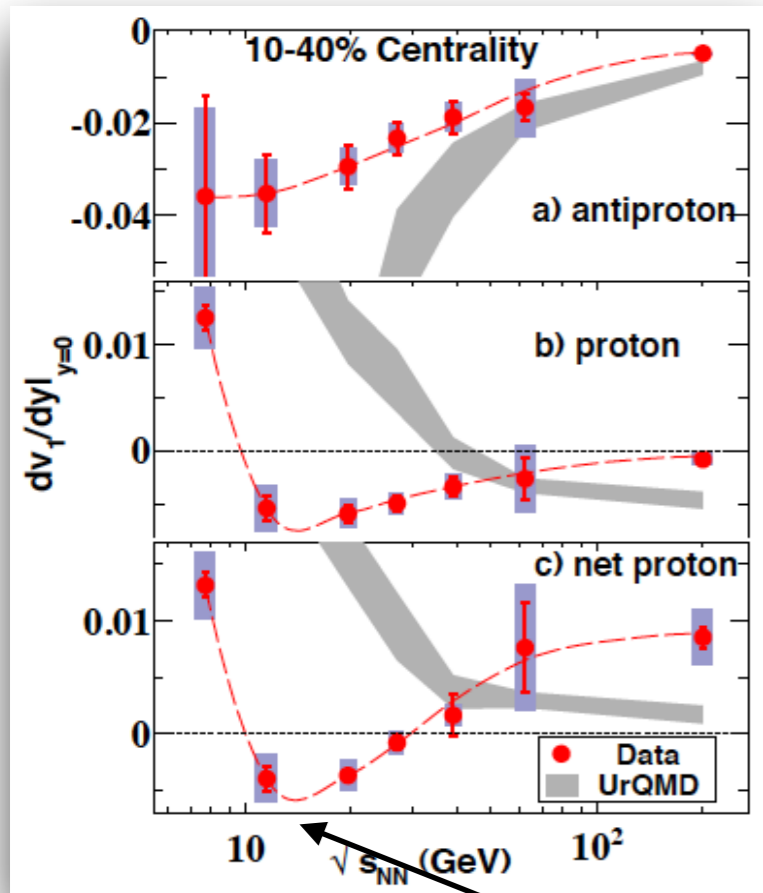

R Singh et. al, arXiv:1304.2969
Acta Phys Pol B, 30, 2705, (1999)

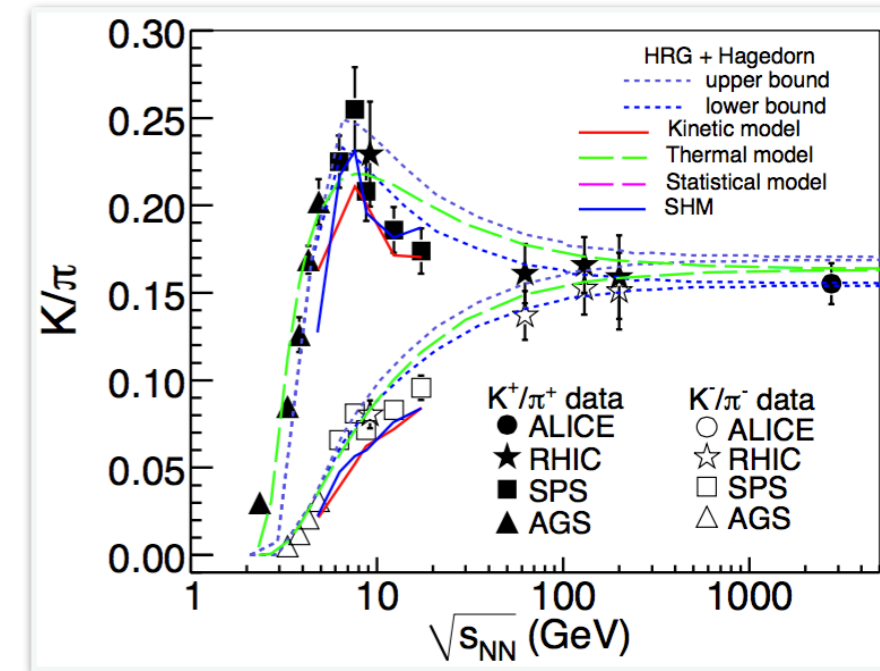

The peak indicates that the system reaches maximum baryonic density at around 10 GeV

Pair production dominant at higher energies.

Evidence for softening of EoS (?)

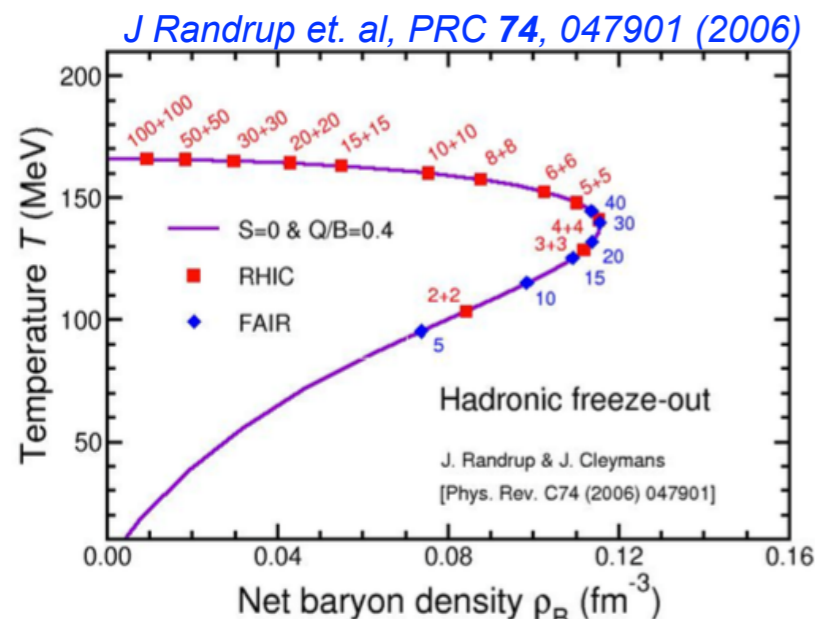

At high baryon (net-baryon) density, one might expect a repulsive force

Strange hadron v_1 at RHIC

New measurements

	quark content
Λ	uds
K^\pm	$u\bar{s}$
K_S^0	$(d\bar{s} - s\bar{d})/\sqrt{2}$
ϕ	$s\bar{s}$



Complimentary to p data



Probe kaon-nucleon potential



Mass close to p, but it is a vector meson

Minimally affected by late-stage hadronic interactions

We can address

- Role of produced quarks in HIC
- Test hypothesis about transport of initial-state quarks

Rapidity dependence of v_1

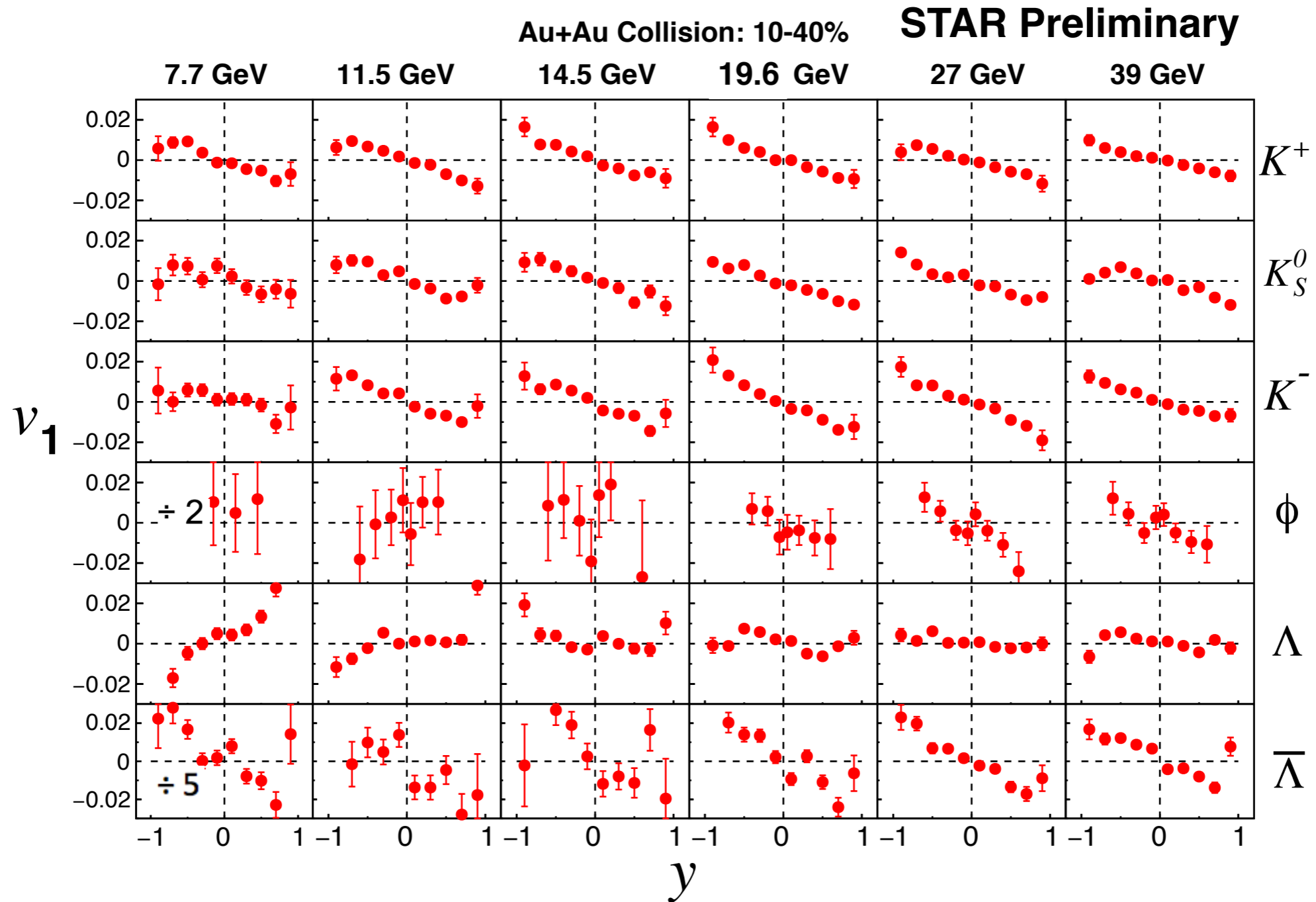

- v_1 -slope extracted by linear fitting ($|y| < 0.8$)
- poor statistics for particles (e.g. $\bar{\Lambda}, \phi$) does not allow stable cubic fit

Energy dependence of dv_1/dy

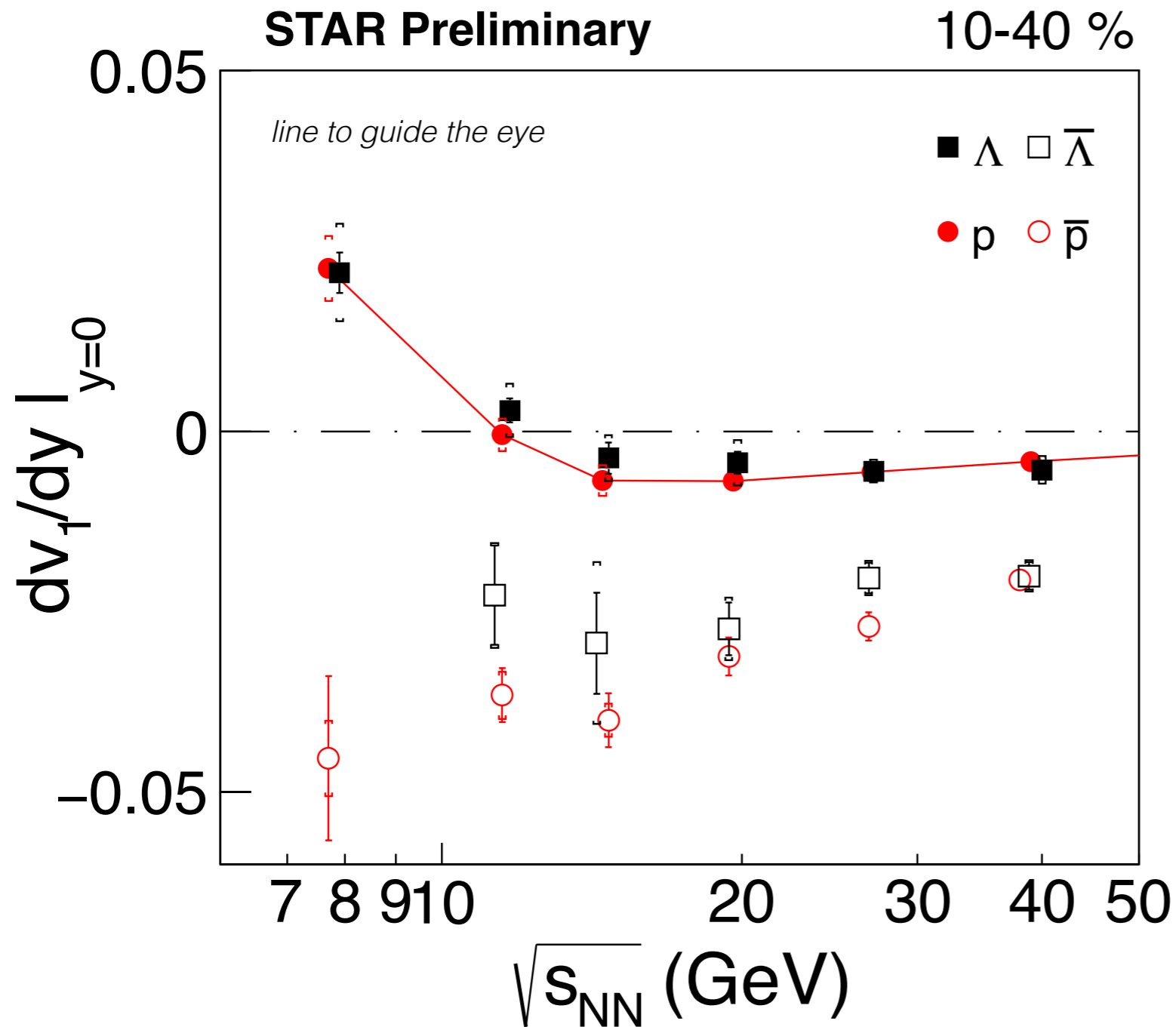

- $(dv_1/dy)_p \sim (dv_1/dy)_{\Lambda}$
- $(dv_1/dy)_{\bar{p}, \bar{\Lambda}} \sim \text{negative}$
- $(dv_1/dy)_{\bar{p}} \sim (dv_1/dy)_{\bar{\Lambda}}$

Energy dependence of dv_1/dy

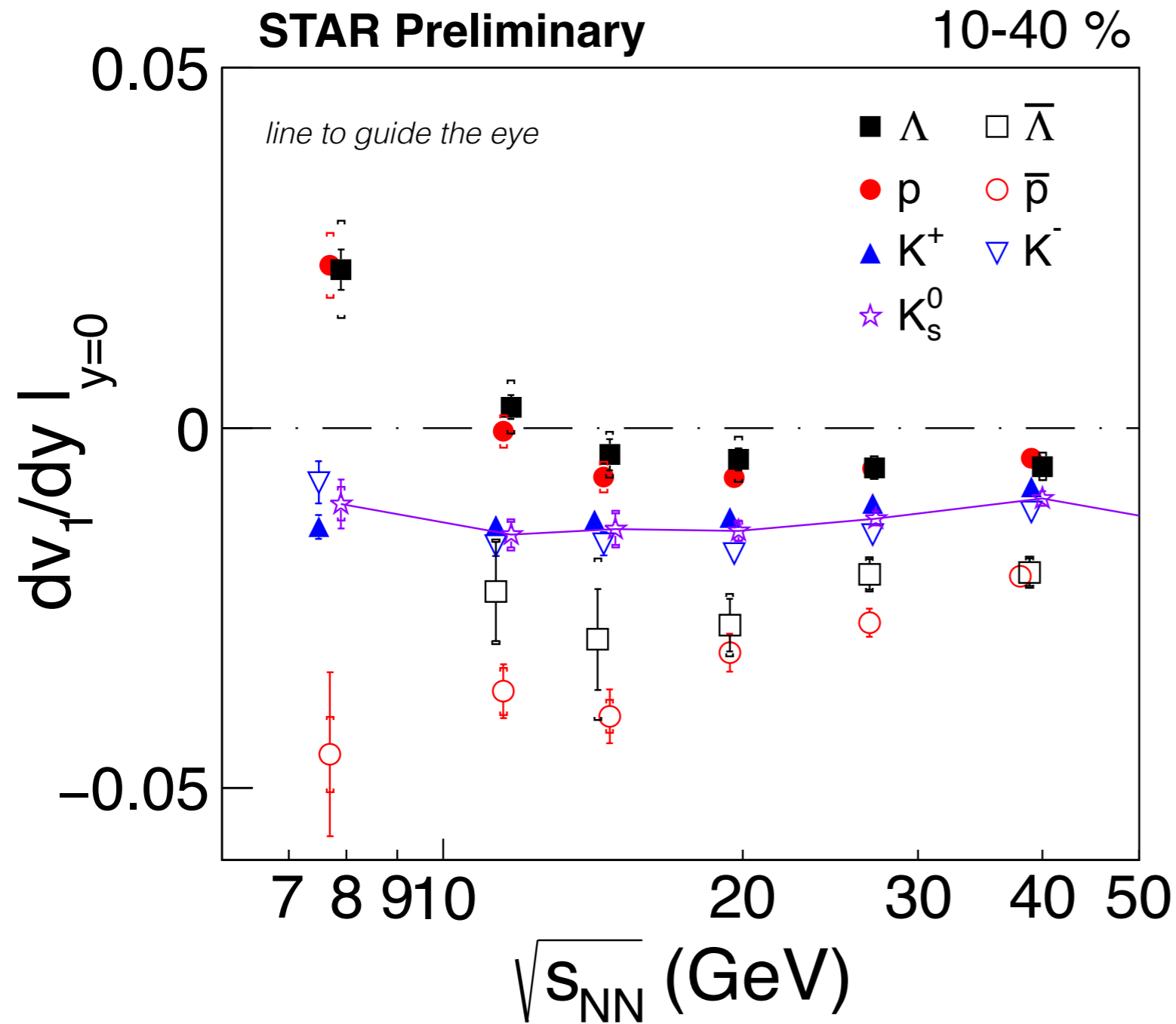

- $(dv_1/dy)_{K^\pm} \sim \text{negative}$
- $(dv_1/dy)_{K_s^0}$ lies in between K^\pm

Energy dependence of dv_1/dy

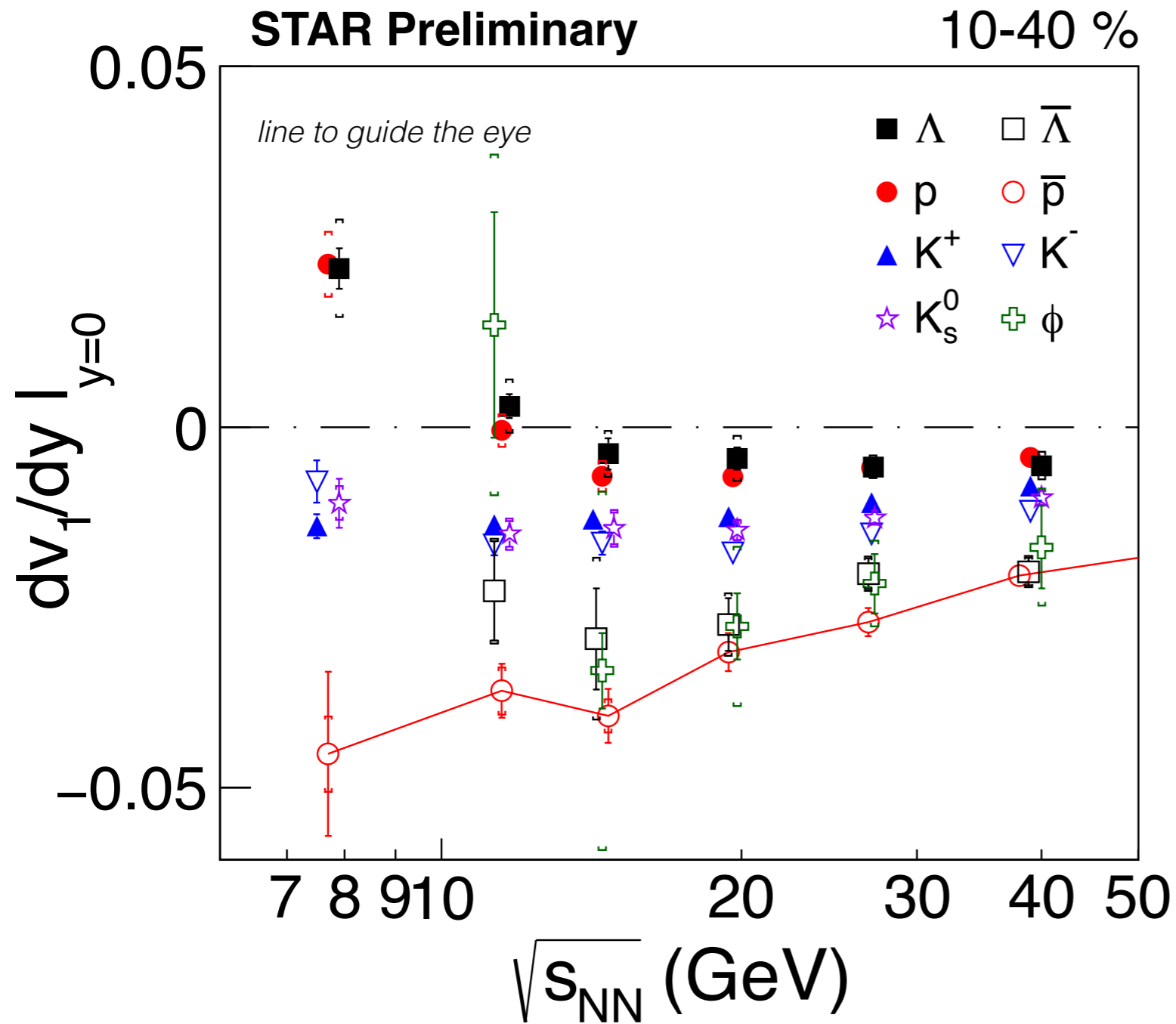

- $(dv_1/dy)_{\bar{\Lambda}, \bar{p}} \sim (dv_1/dy)_\phi$ for energies above 14.5 GeV
- $(dv_1/dy)_\phi \sim 0$ at 11.5 GeV with large stat. uncertainty

Energy dependence of dv_1/dy

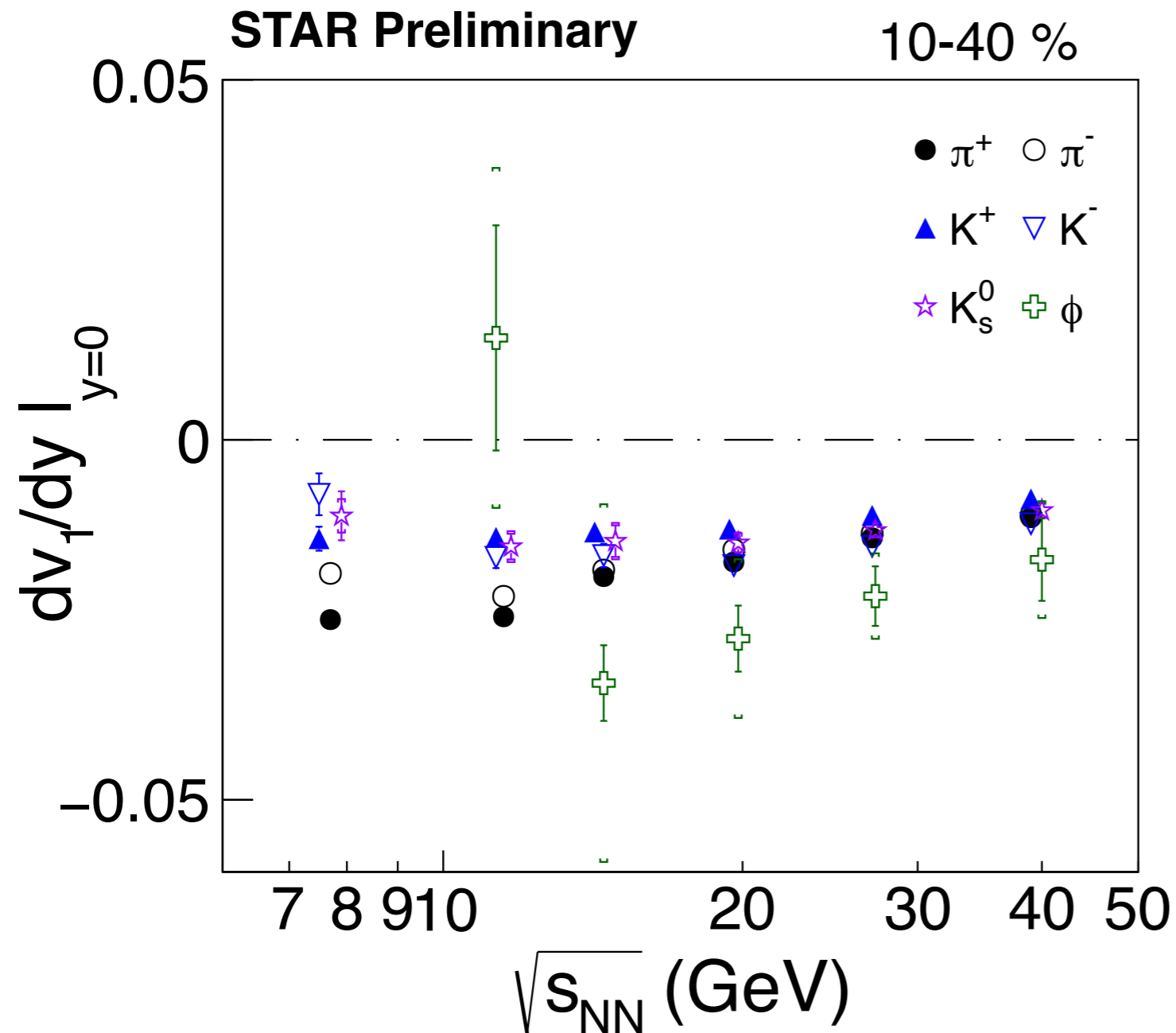

- $(dv_1/dy)_K < (dv_1/dy)_\phi$ for energies above 14.5 GeV
- $(dv_1/dy)_\phi \sim 0$ at 11.5 GeV with large stat. uncertainty

Among the mesons, the particle (e.g. ϕ) with more produced quarks have larger magnitude of v_1 -slope.

Energy dependence of dv_1/dy

UrQMD: S. Bass et al, Prog. Part. Nucl. Phys 41, 255, (1998)

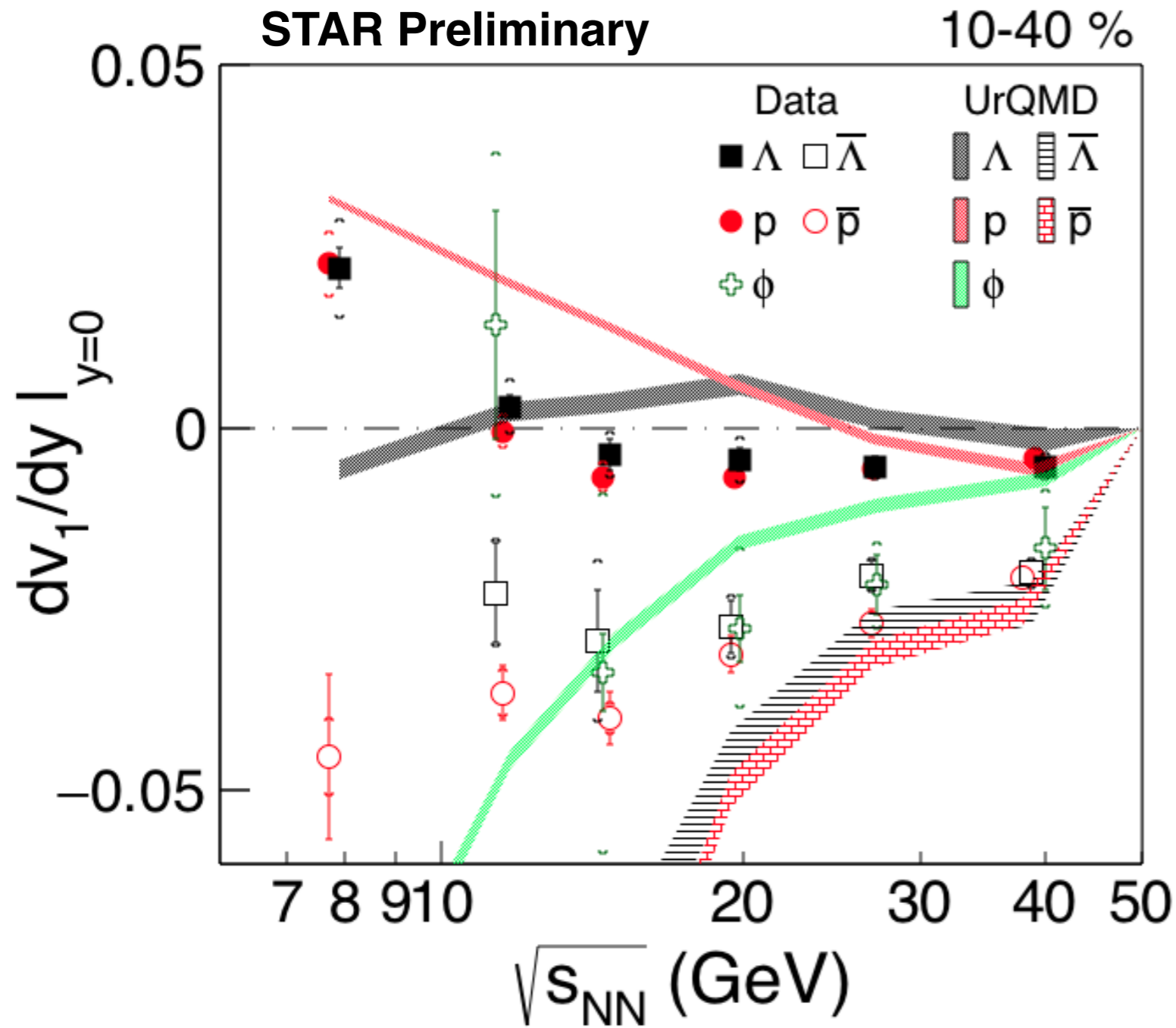

- $(dv_1/dy)_{\text{UrQMD-}\Lambda, \phi}$: deviate from data below 19.6 GeV
- $(dv_1/dy)_{\text{UrQMD-}\bar{\Lambda}, \phi}$: qualitatively similar trend to data for higher energies

Energy dependence of dv_1/dy

HSD: W. Cassing et al, arXiv: 1408.4313

UrQMD: S. Bass et al, Prog. Part. Nucl. Phys 41, 255, (1998)

STAR Preliminary

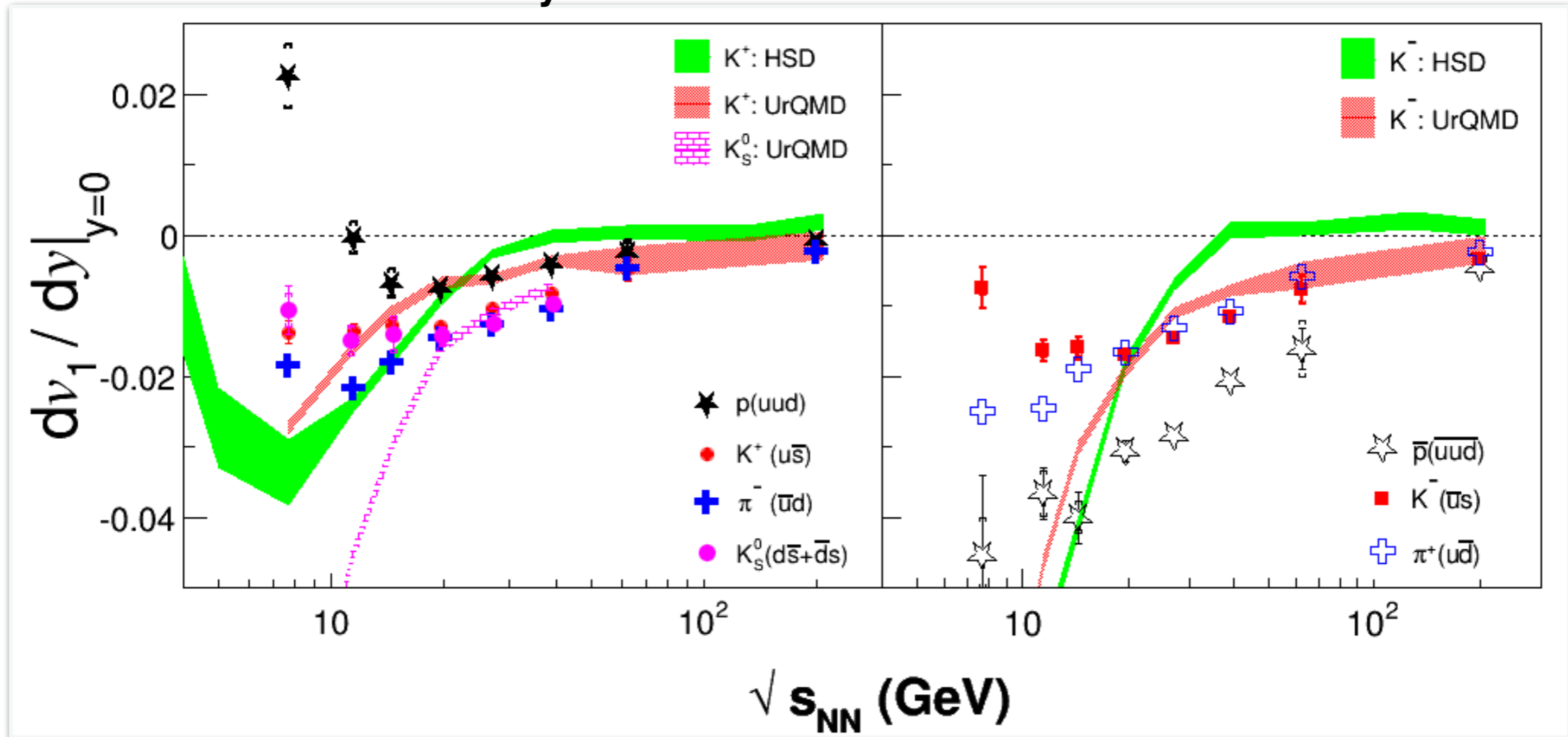

- Particles in left panel expected have more stopped initial-state nucleons than the anti-particles in right panel
- $dv_1/dy(K^\pm, K_S^0)$ from UrQMD/HSD model can not explain data

Energy dependence of net-particle v_1

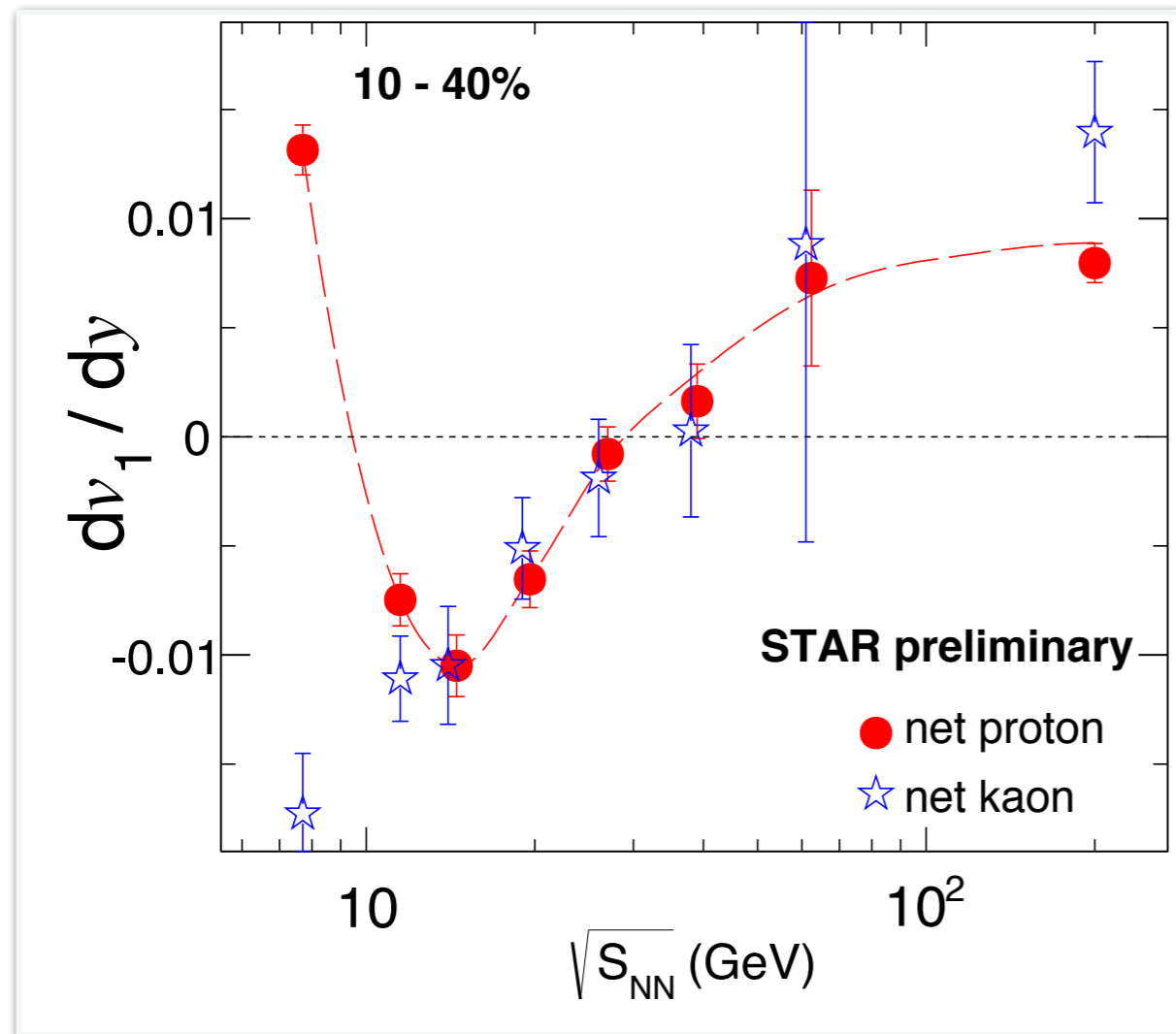

To disentangle contributions from produced quarks & transported quarks

$$F_p = r_1 F_{\text{anti-p}} + (1-r_1) F_{\text{net-p}}$$

$$F_{K^+} = r_2 F_{K^-} + (1-r_2) F_{\text{net-K}}$$

$$F = dv_1/dy, \quad r_1(y) = \text{anti-p}/p$$

$$r_2(y) = K^-/K^+$$

- $(dv_1/dy)_{\text{net-K}} \sim (dv_1/dy)_{\text{net-p}}$ at and above 14.5 GeV but they deviate at lower energies

BES-II at RHIC

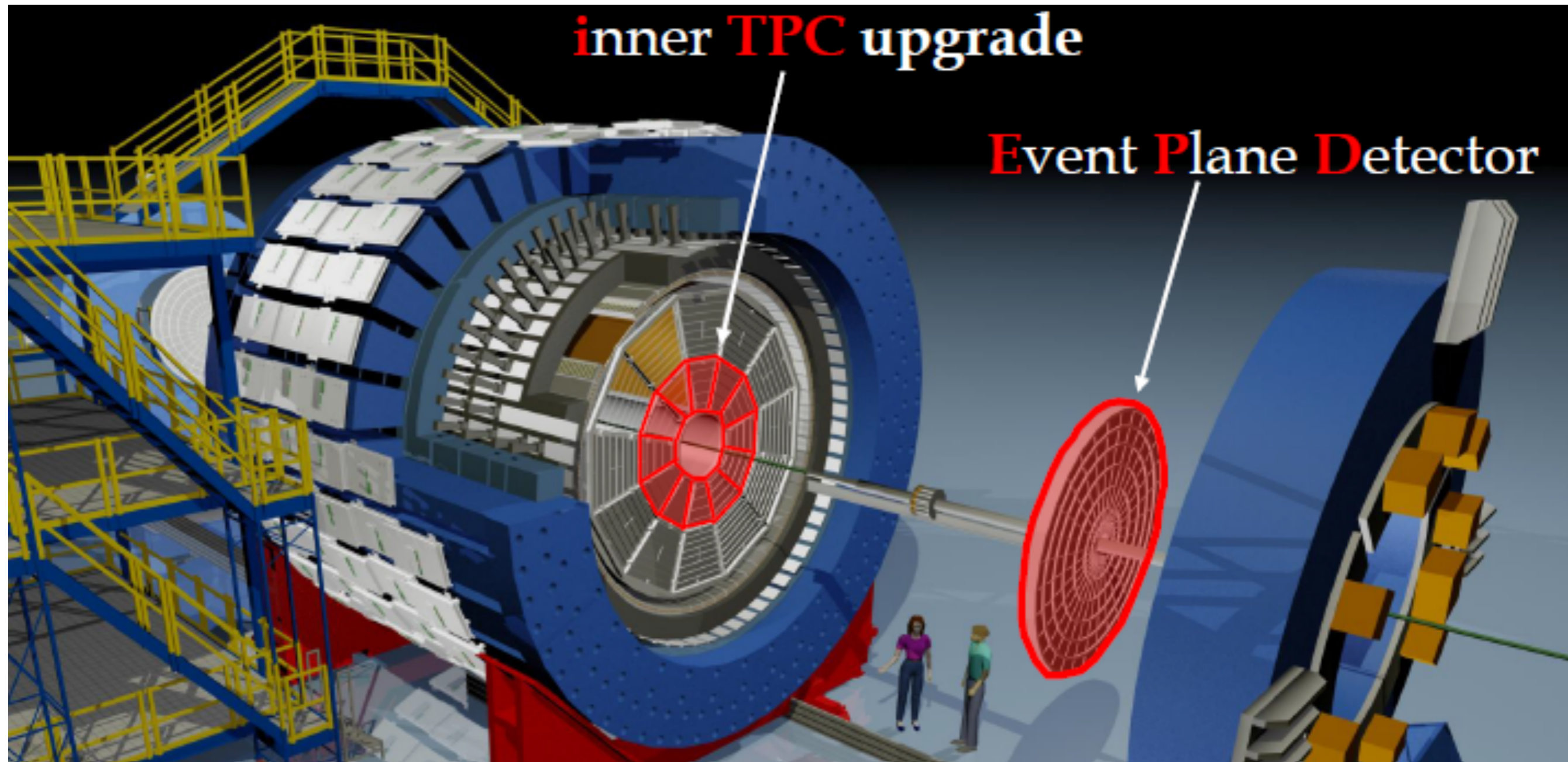

iTPC ($-1.7 < |\eta| < 1.7$)

- extended coverage
- better dE/dx

EPD ($2.1 < |\eta| < 5.1$)

- improved EP resolution
- TPC independent centrality estimation

BES-II at RHIC

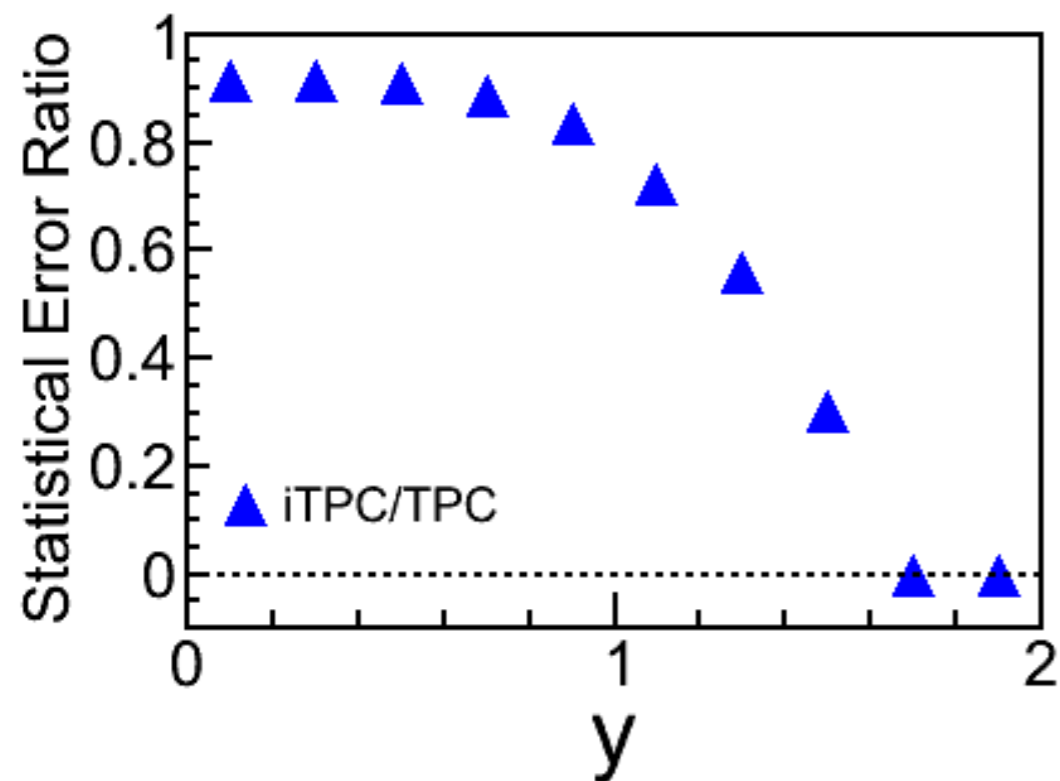
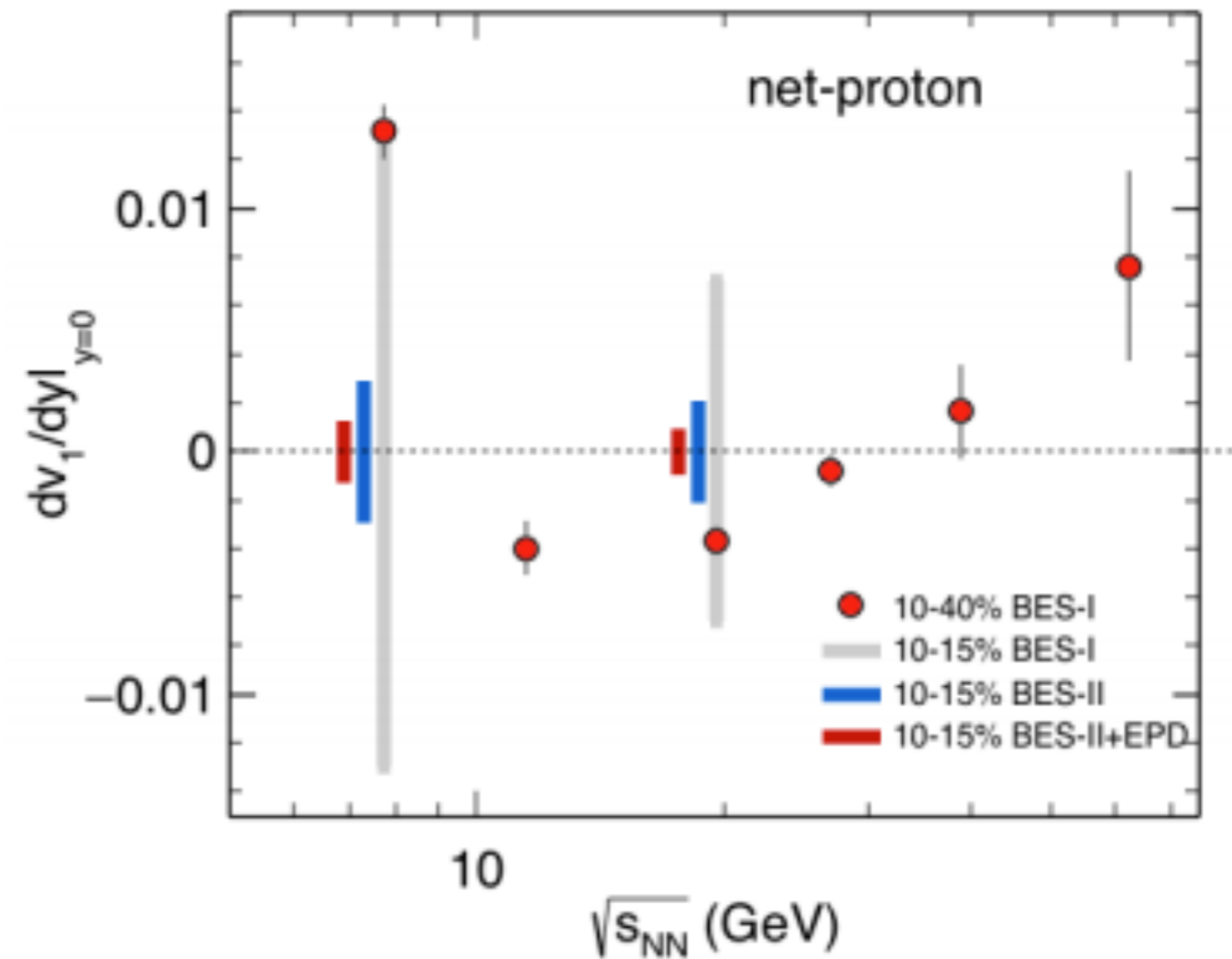
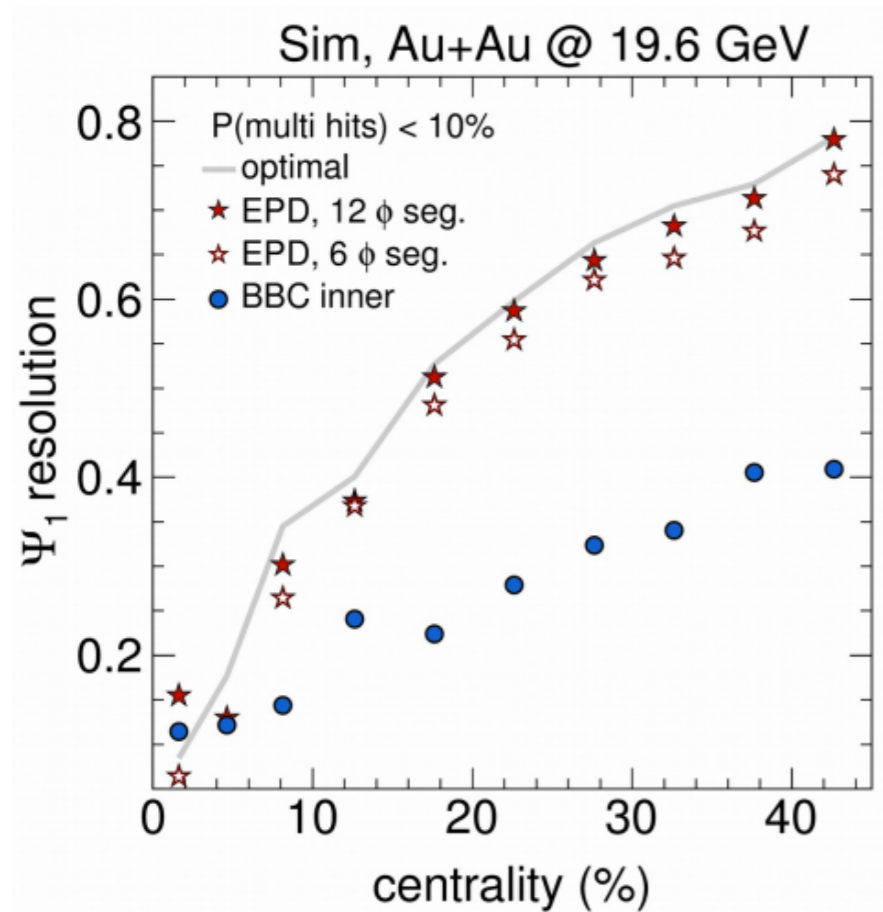

- improvement in EP resolution
- reduction in statistical uncertainty

Summary and outlook

STAR published results show a minimum in dv_1/dy for proton and net-protons and a double sign-change in net-proton dv_1/dy

New preliminary results:

➤ *$dv_1/dy(p) \sim dv_1/dy(\Lambda)$ and both show sign-change $\sqrt{s_{NN}} < 14.5$ GeV*

➤ *$dv_1/dy(\text{anti-}\Lambda, \text{anti-}p) \sim dv_1/dy(\phi)$ for $\sqrt{s_{NN}} > 11.5$ GeV*

➤ *$dv_1/dy(\text{net-}p) \sim dv_1/dy(\text{net-K})$ for $\sqrt{s_{NN}} > 14.5$ GeV: quark transport*

while $dv_1/dy(\text{net-K})$ stays negative for $\sqrt{s_{NN}} < 14.5$ GeV

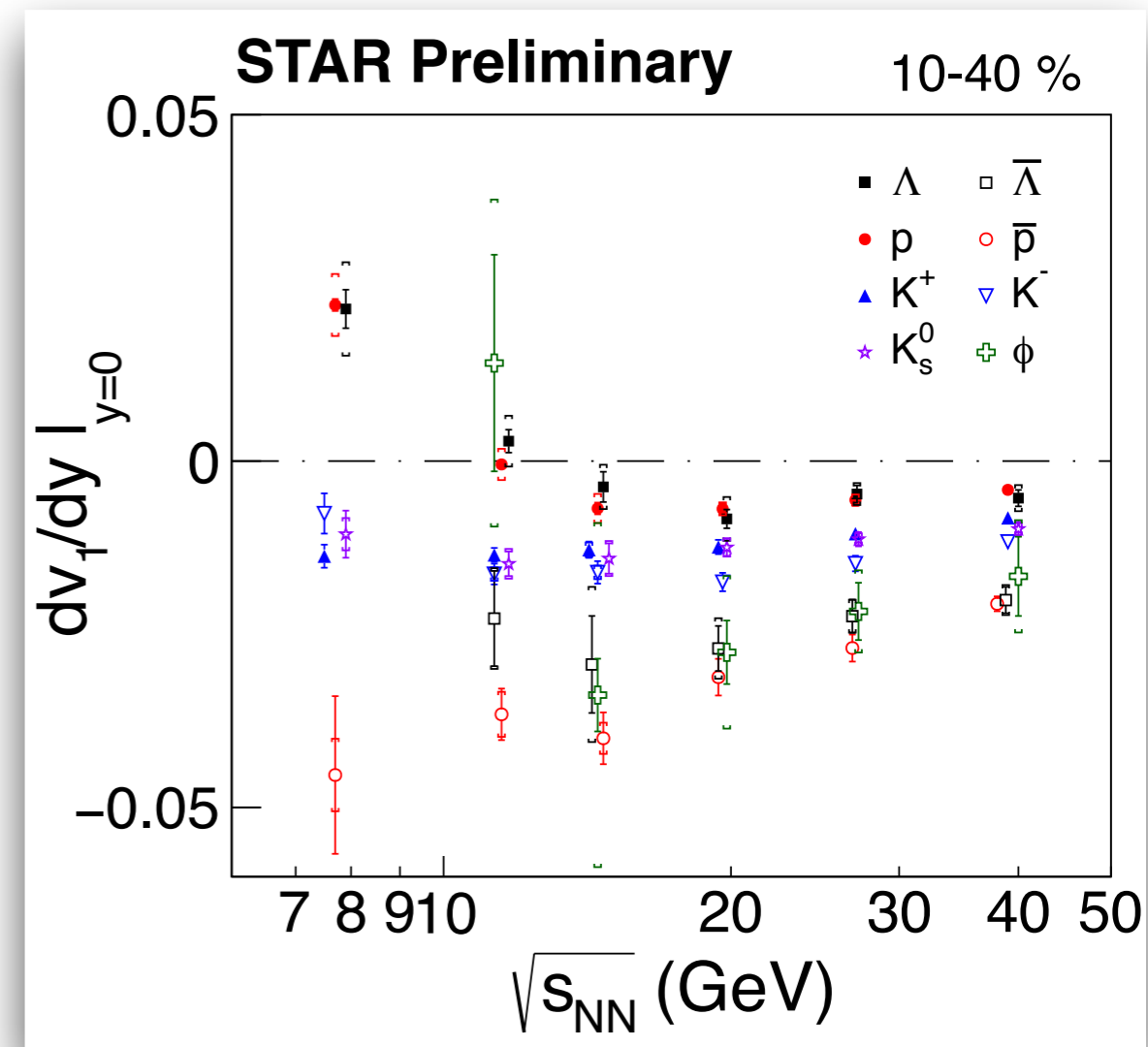

Summary and outlook

- ➔ *Present models can not explain main features of data*
- ➔ *New set of results from STAR will put stringent constraint on theoretical models*
- ➔ *More theoretical progress needed for a clear interpretation of data*
- ➔ *Data from BES-II with more statistics and upgraded detectors will provide results with more precision*

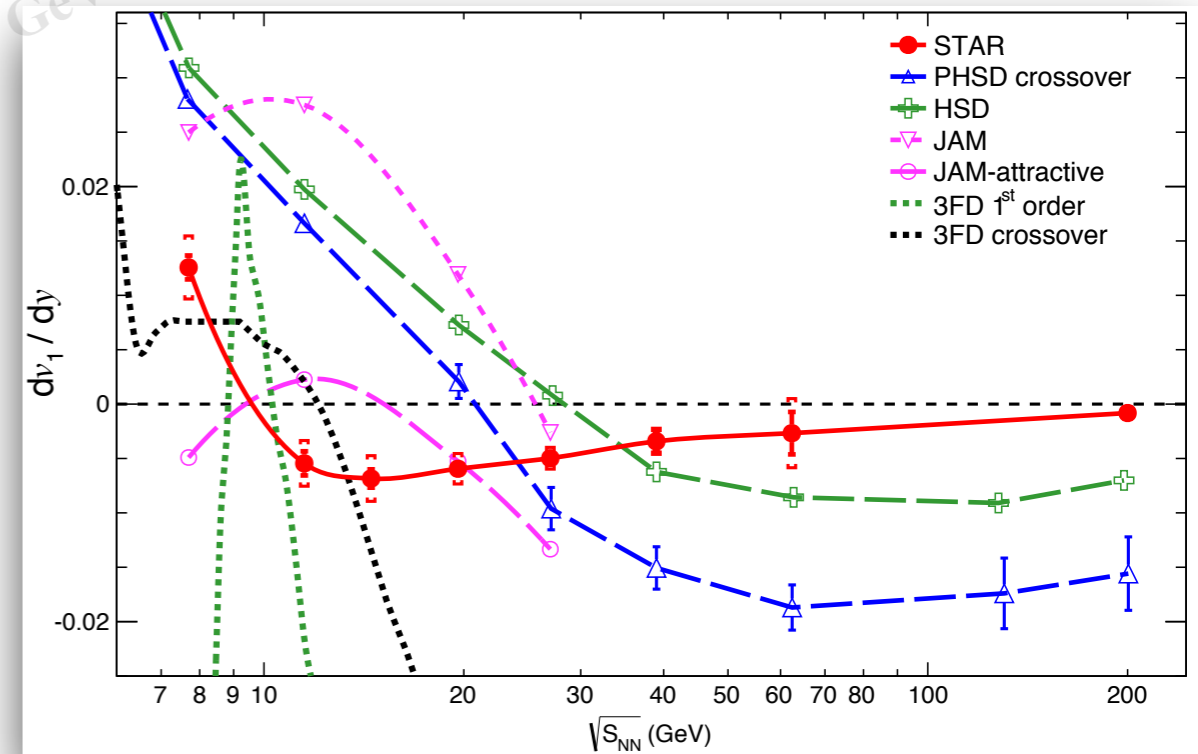

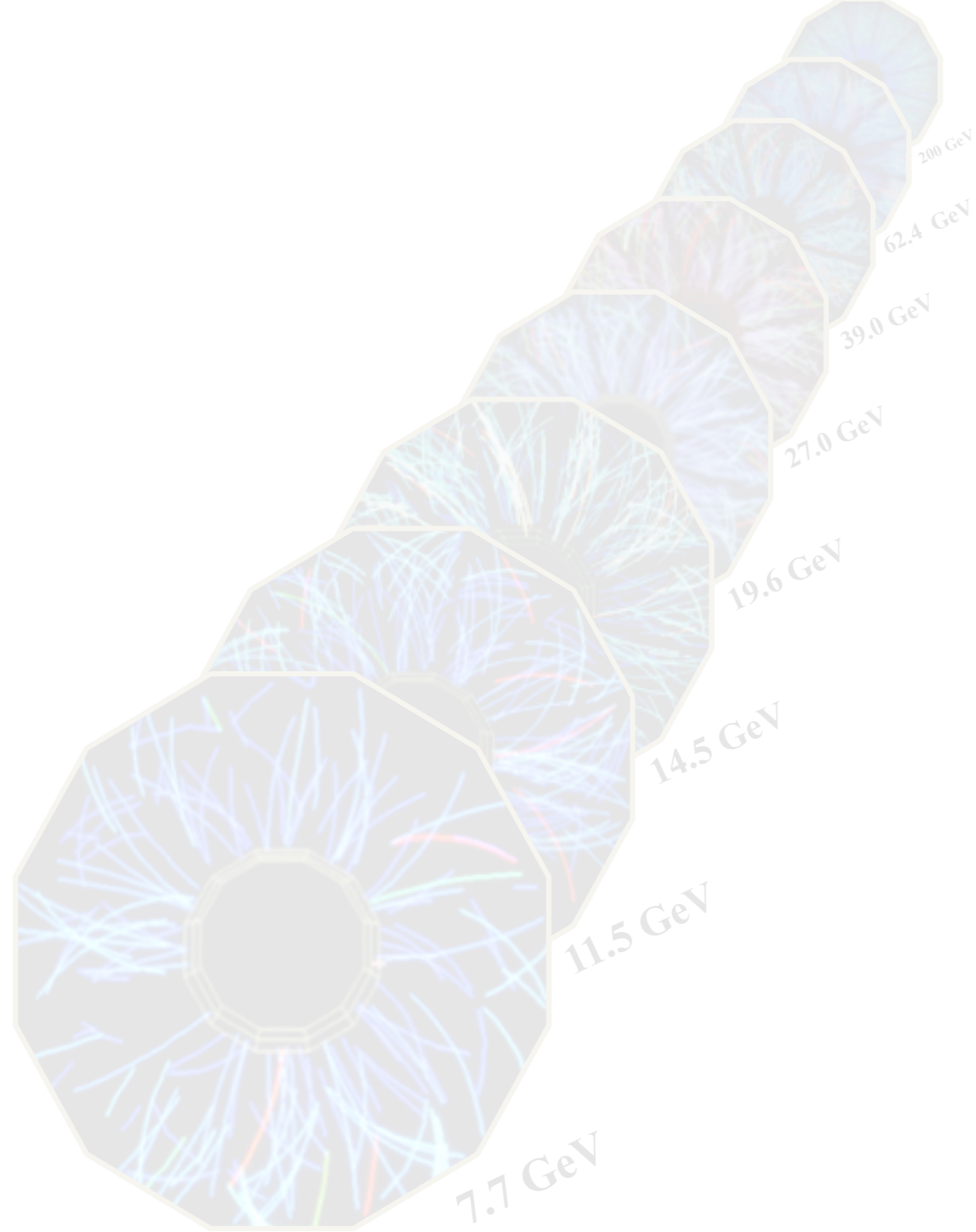

Thank you

Interpretation of STAR dv_1/dy data by different models

Frankfurt hybrid

"...we find that essentially all models, including the standard hadronic transport UrQMD, cannot even describe the qualitative behavior, observed by experiment, of the proton directed flow. All models severely overestimate the data, even though other observables, like the radial or elliptic flow, are usually well described within these models."

3FD

"... with available data indicated a definite advantage of the deconfinement (crossover and first-order) scenarios over the purely hadronic one, especially at high (RHIC) collision energies. However, predictions of the crossover and first-order-transition scenarios looked very similar so far. Only a slight preference could be given to the crossover EoS. In the case of the directed flow we can definitely conclude that the best overall reproduction of the STAR data is achieved with the crossover EoS. The first-order-transition scenario gives results which strongly differ from those in the crossover scenario, especially for the proton v_1 ."

PHSD/HSD

"... Still sizable discrepancies with experimental measurements in the directed flow characteristics are found Our flow analysis shows no indication of a first-order transition. However, we have found further strong evidence that the dynamics of heavy-ion reactions at lower SPS and AGS energies is far from being understood especially on the hadronic level."

JAM:

"More detailed systematic studies are needed by using a fully baryon density dependent EoS, in order to draw a conclusion that minimum of dv_1/dy is a result of the softening of the EoS which may be caused by a first-order phase transition. ... It seems obvious to infer a softening of the EoS from the experimentally observed collapse of net-proton flow when the c.m. energy is increased from 7 to 11 GeV. However, the statement of a discovery of the "softening" of the EoS from the net-proton v_1 data shows even more convincing evidence for the "phase transition" as we observe the re-bounce at higher energies, namely STAR observed second change of sign of the v_1 values of the net-protons at $\sqrt{s_{NN}} \approx 40$ GeV back to positive v_1 at higher energies [1]. This shows that the soft region is overcome, and the directed flow picks up steam again, due to the re-hardening of the EoS at considerably larger energy densities."

Results from RHIC and LHC

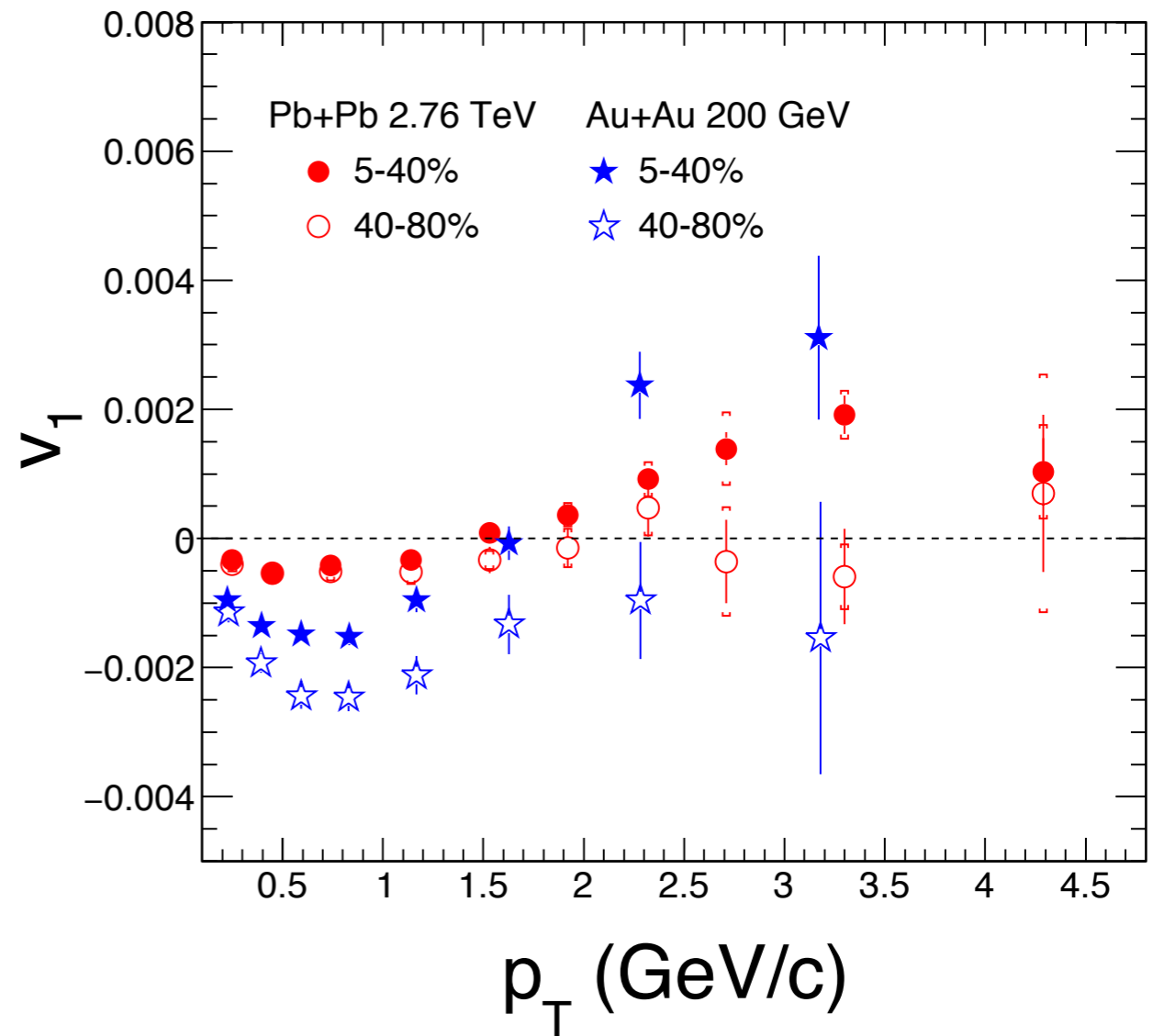
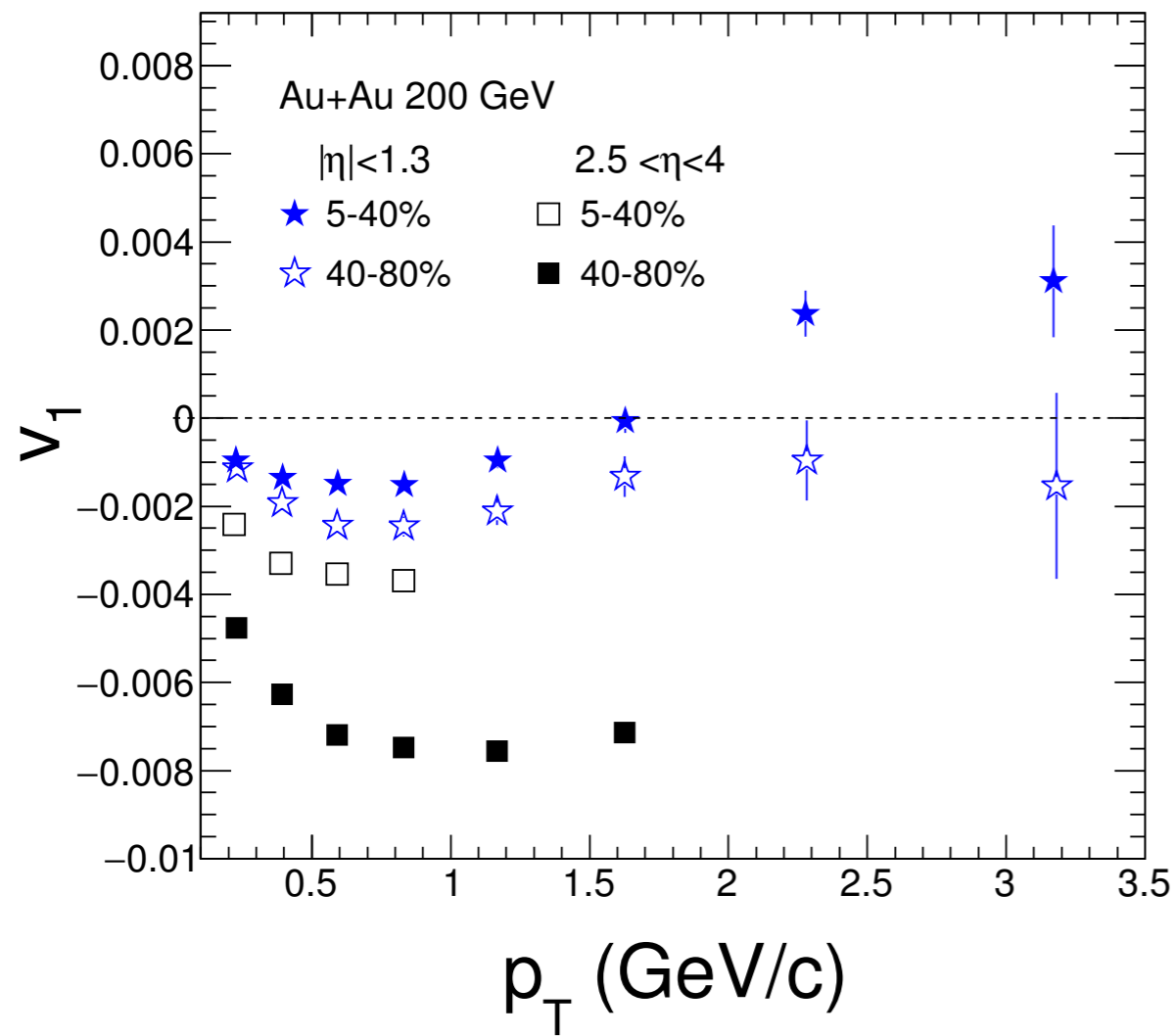

Baryon Density

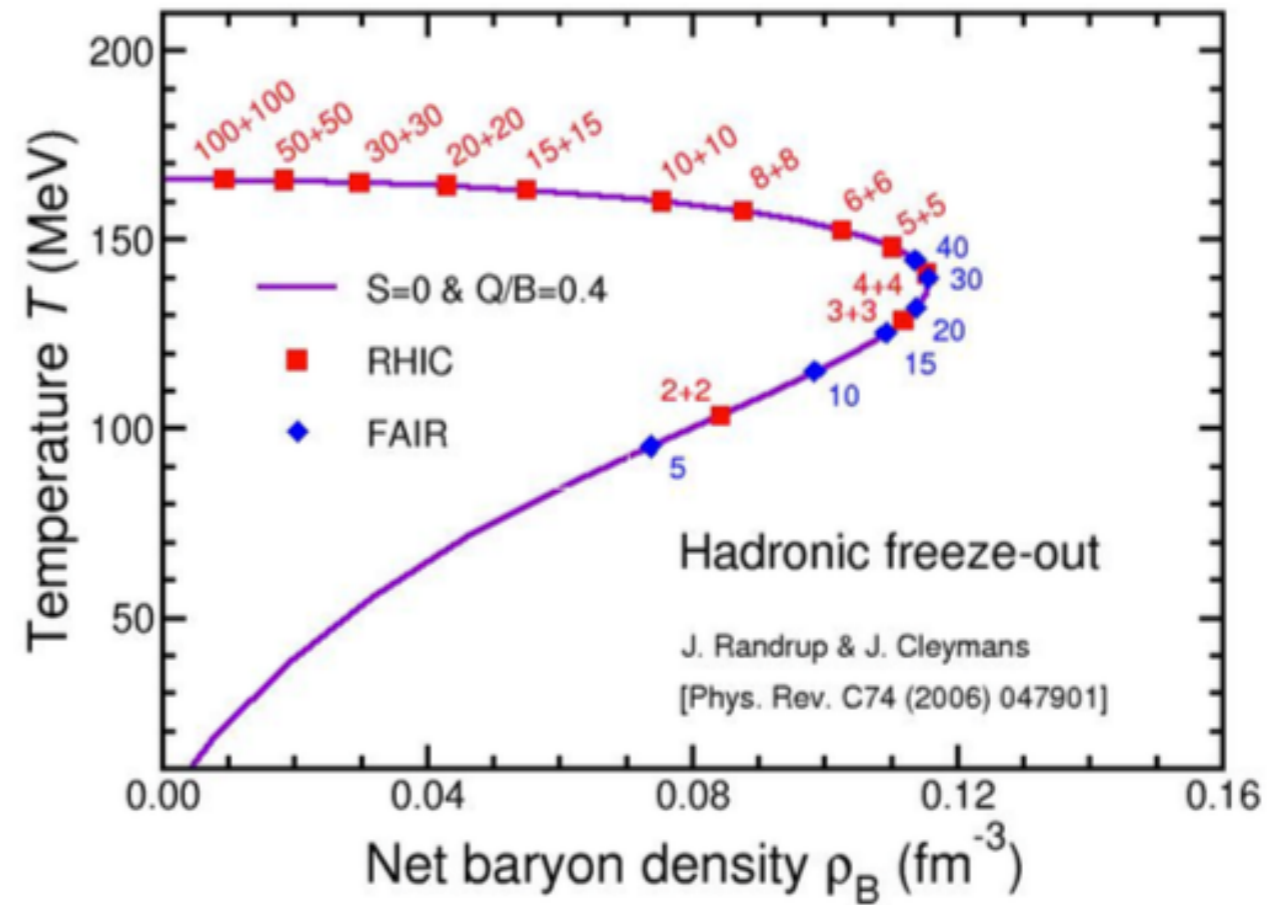
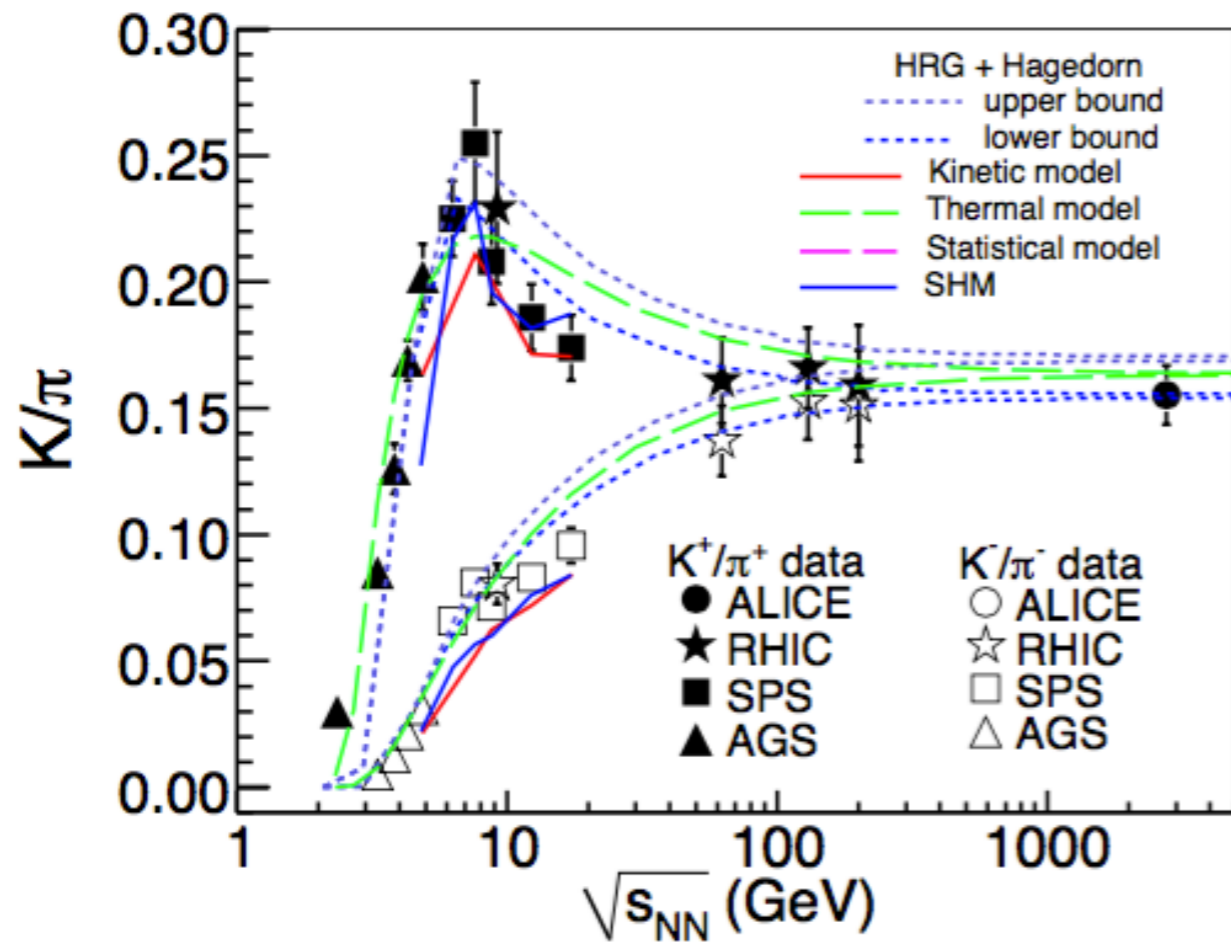

JAM Calculation

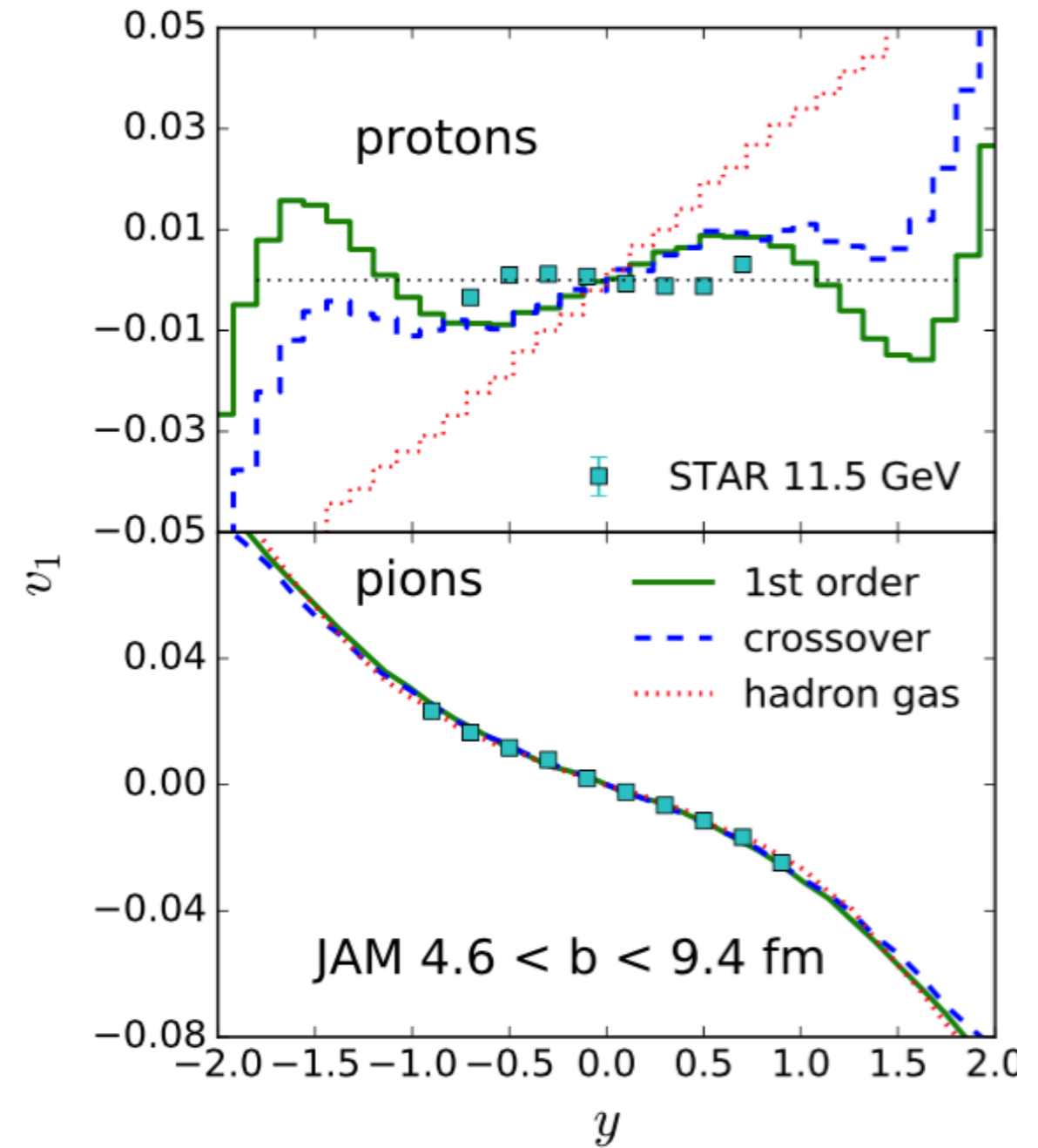
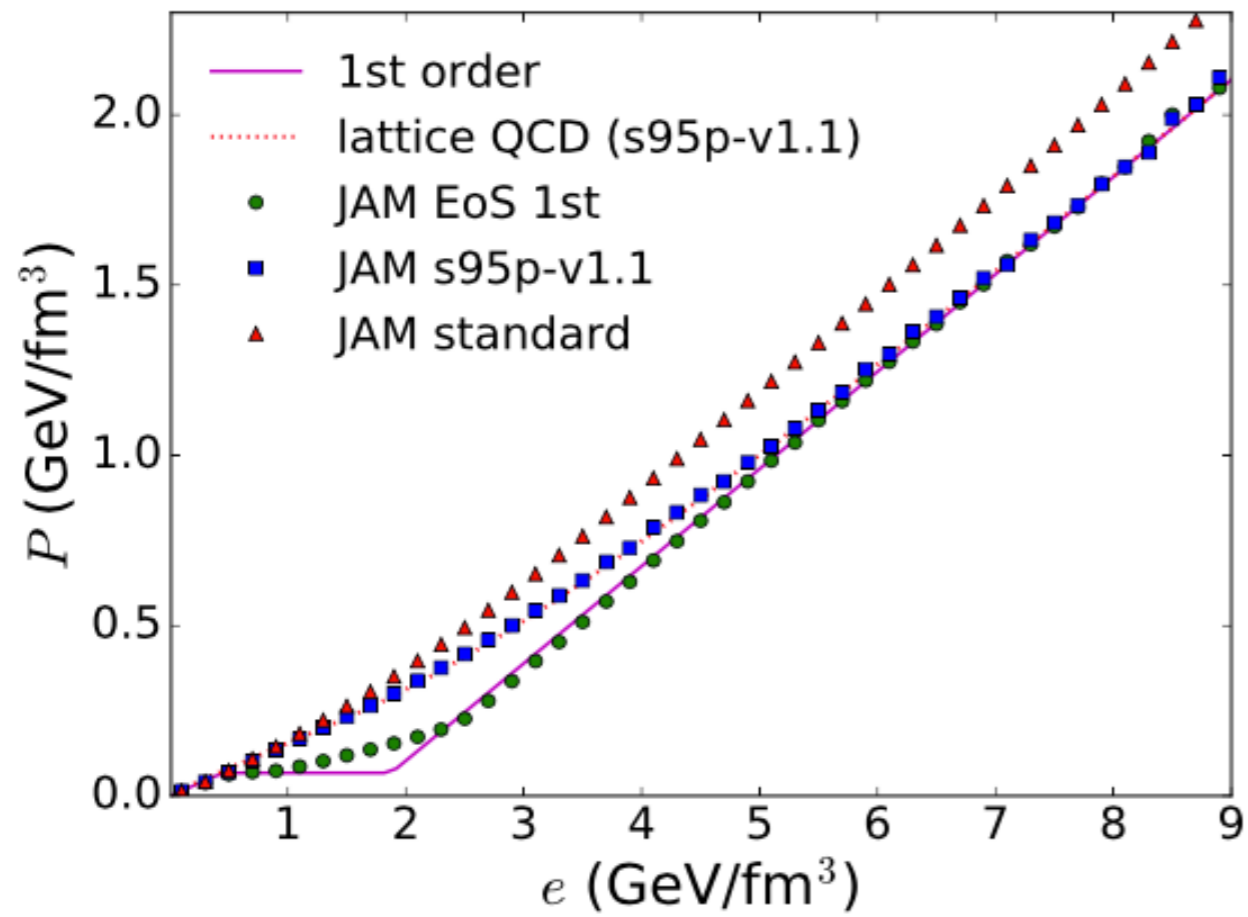

BES at RHIC

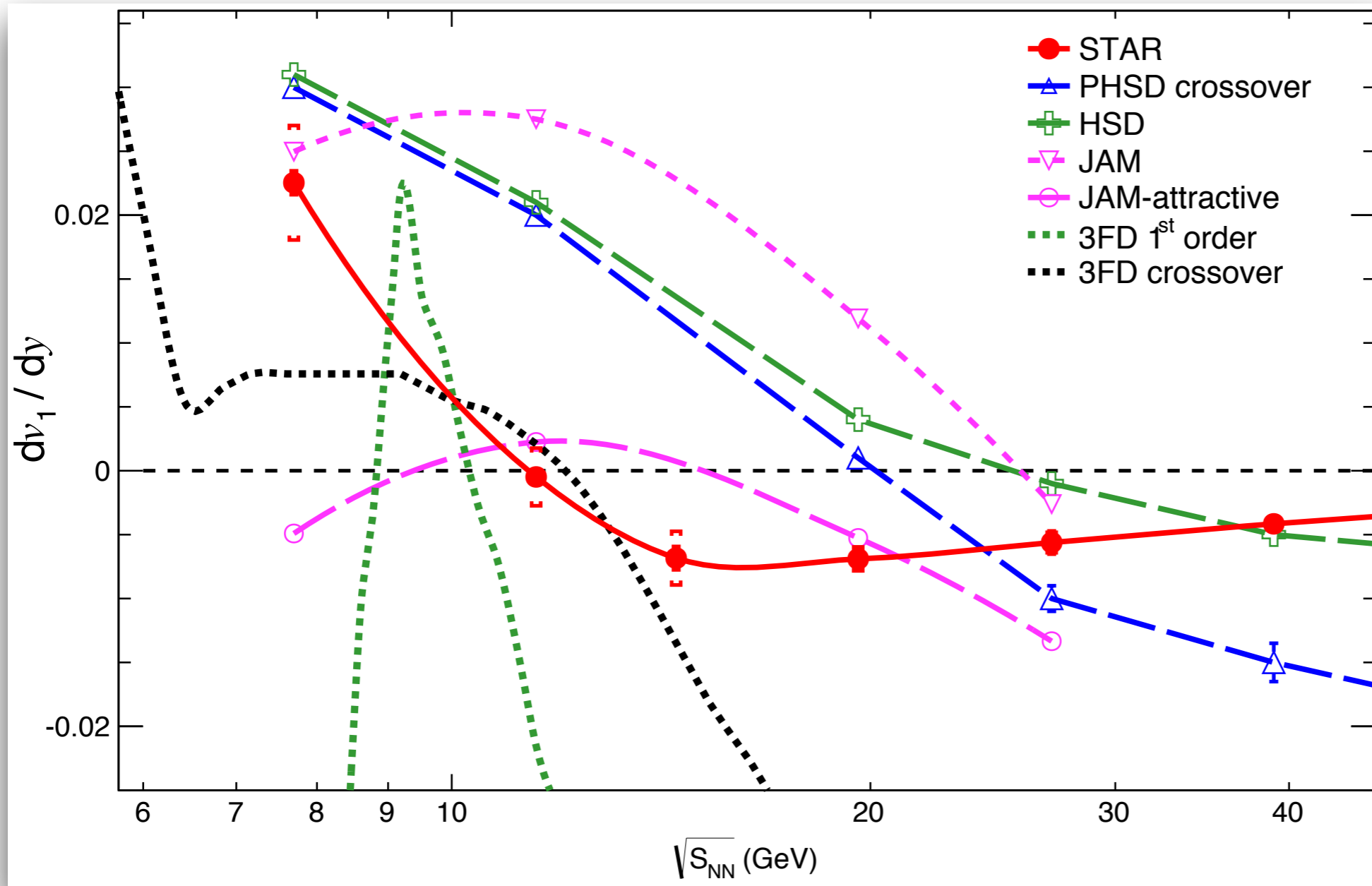

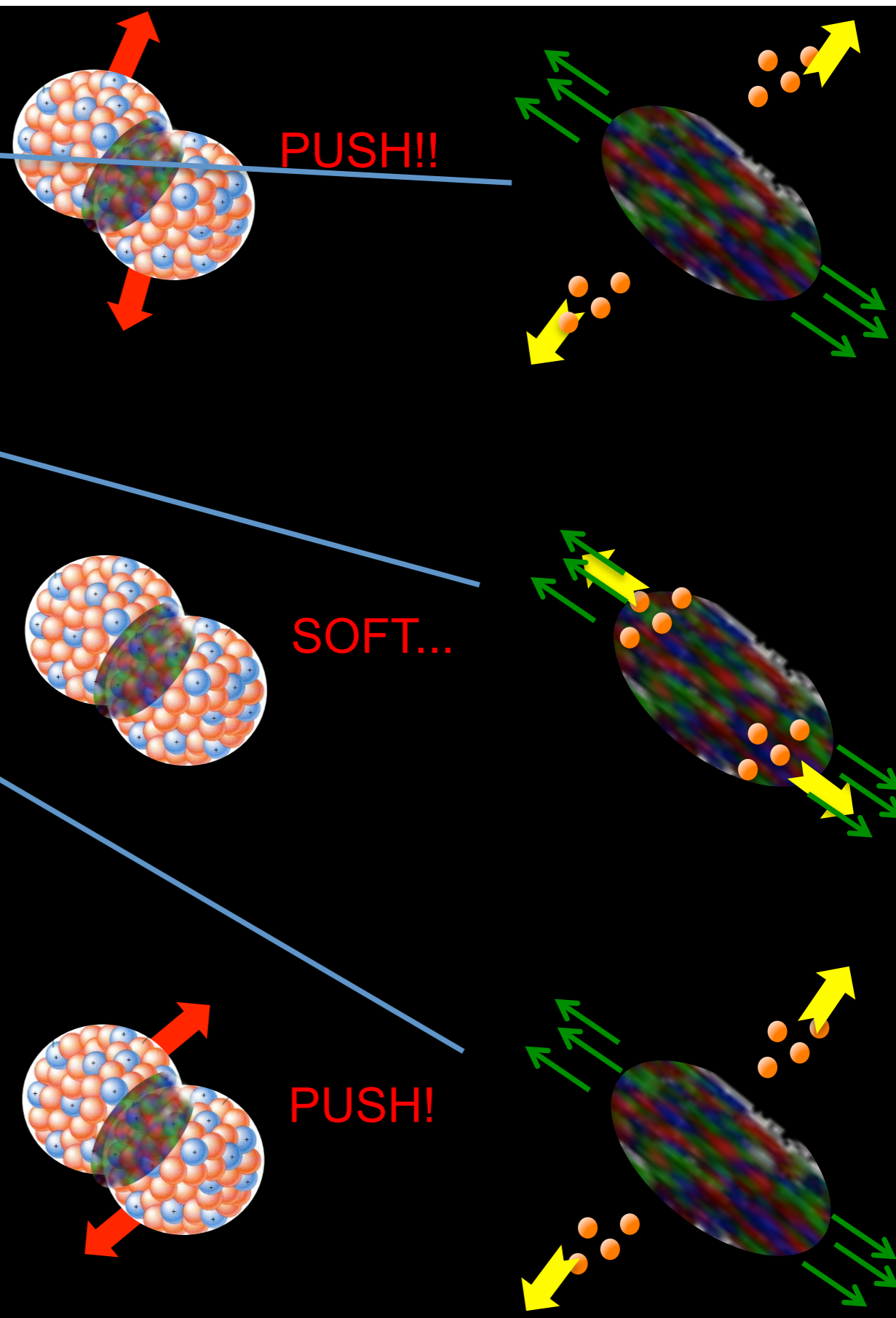
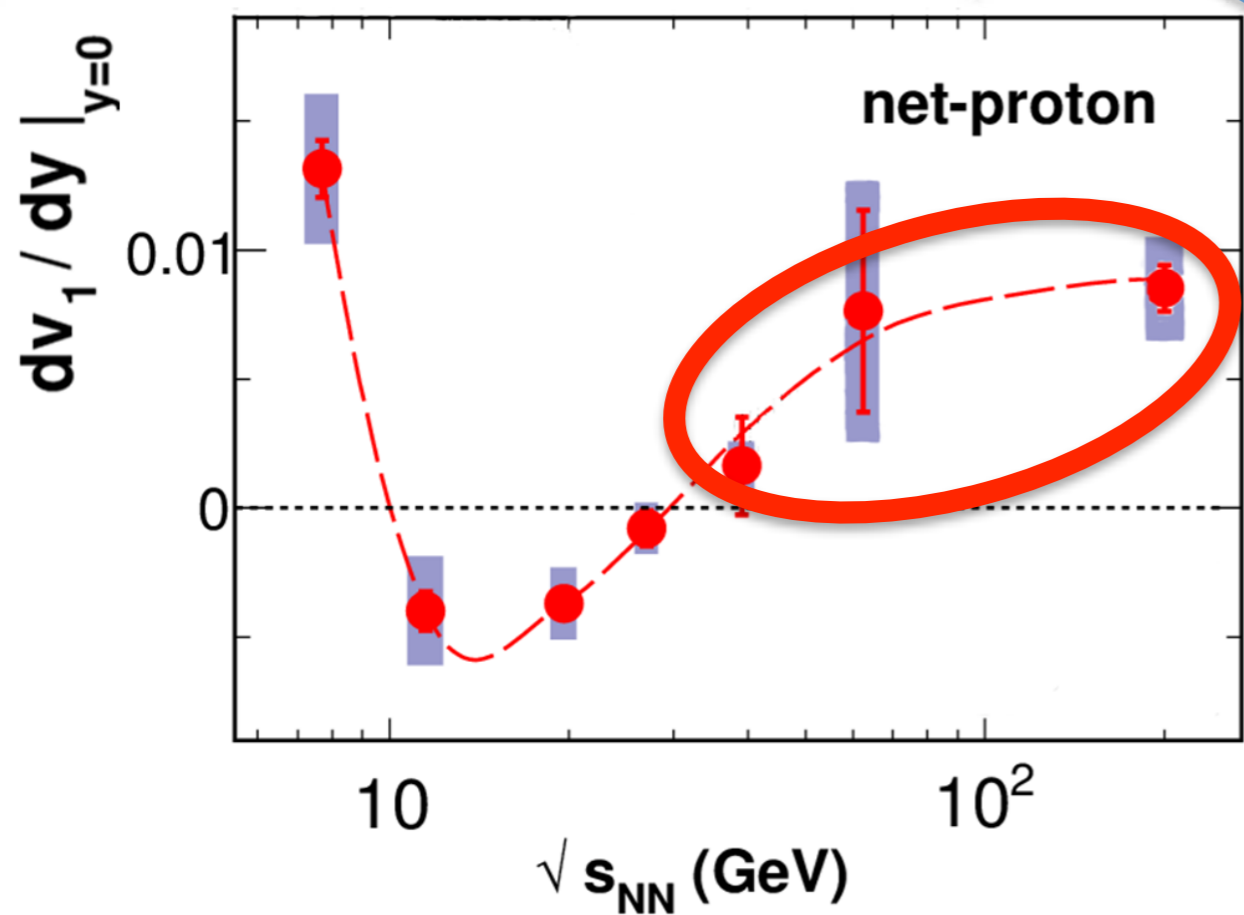
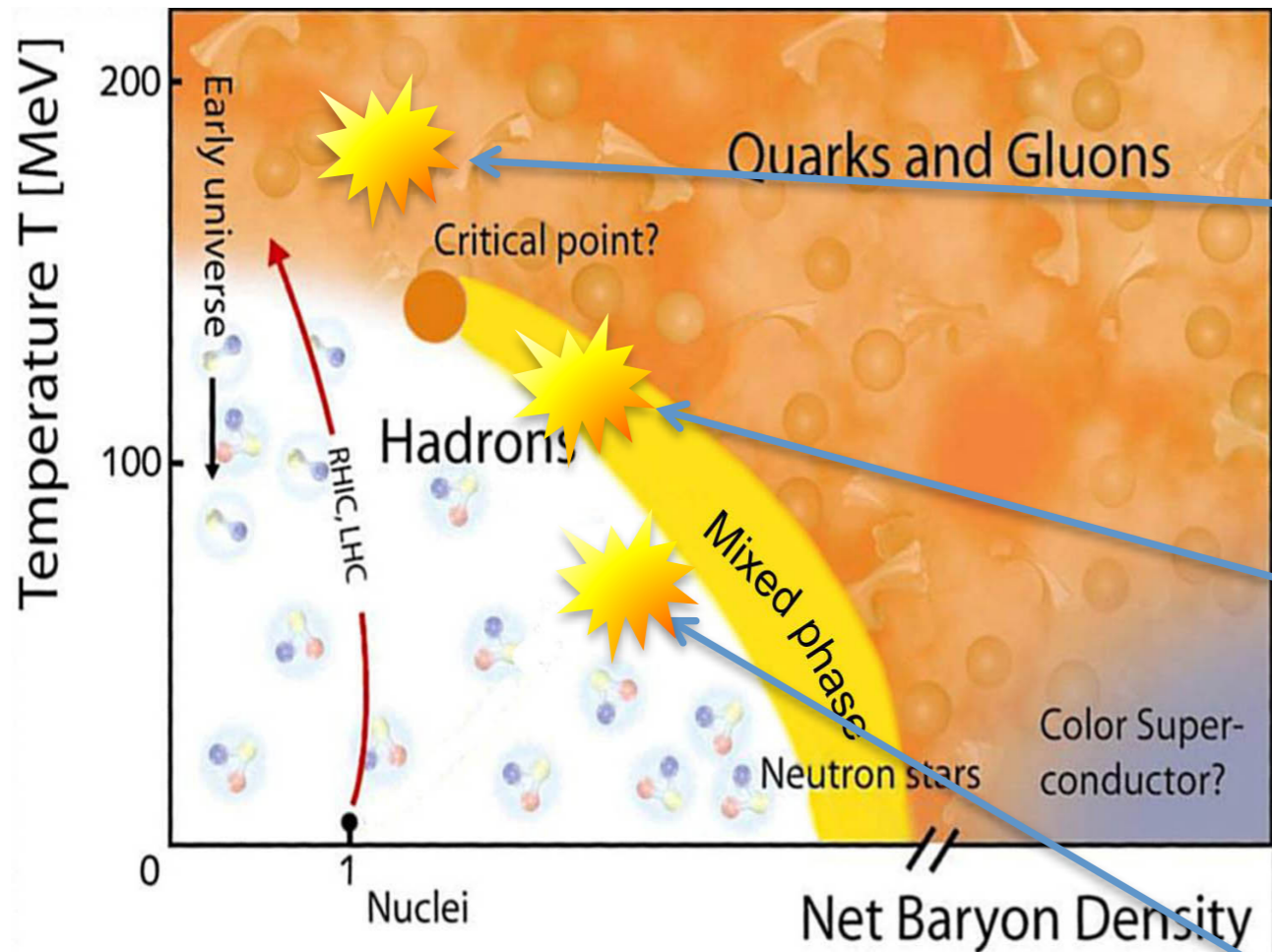

Cartoon made by Mike Lisa